

Part Number: [0002061132](#)
Status: **Active**
Overview: Standard .062"
Description: 1.57mm (.062") Diameter, Standard .062" Pin and Socket Crimp Terminal, Series 1855, Female, with Tin (Sn) Plated Brass Contact, 24-30 AWG, Bag

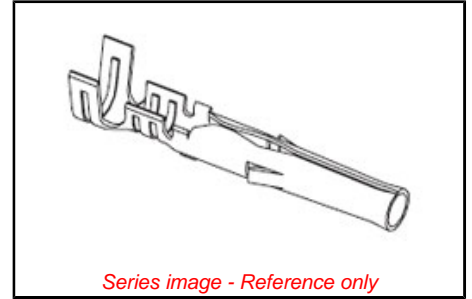

General

Product Family	Crimp Terminals
Series	1855
Overview	<u>Standard .062"</u>
Product Name	Standard .062"

Physical

Gender	Female
Material - Metal	Brass
Material - Plating Mating	Tin
Material - Plating Termination	Tin
Packaging Type	Bag
Plating min: Mating (µin)	20
Plating min: Mating (µm)	0.50
Plating min: Termination (µin)	20
Plating min: Termination (µm)	0.50
Termination Interface: Style	Crimp or Compression
Wire Insulation Diameter	1.02-2.29mm (.040-.090")
Wire Size AWG	24
Wire Size AWG	26
Wire Size AWG	28
Wire Size AWG	30
Wire Size mm ²	N/A

Material Info

Old Part Number	1855-(P901)L
-----------------	--------------

EU RoHS
ELV and RoHS
Compliant

China RoHS



PART NO.	ENG. NO.	
02-06-1131	1855-(P901)	
02-06-1132	1855-(P901L)	
02-06-5137	1855-(P591)	OBSOLETE
02-06-5136	1855-(P591L)	OBSOLETE
02-06-5138	1855-(P561)	
02-06-5139	1855-(P561L)	
02-06-5130	1855-(P550)	
02-06-5135	1855-(P550L)	
02-06-5147	1855-(P228)	
02-06-5148	1855-(P228L)	
02-06-1141	1855-1(P901)	
NOT TOOLED	1855-1(P901L)	
02-06-1143	1855-(P9011)	

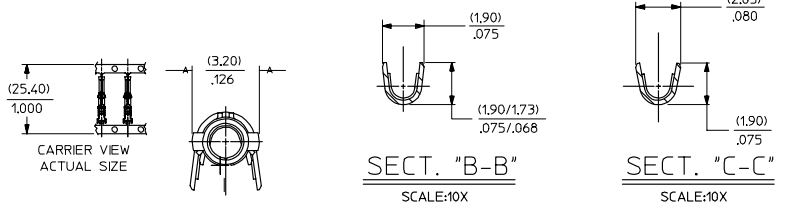

LEGEND

1855-*(***)*

BLANK-WITH LOCKING TABS
1-WITHOUT LOCKING TABS

P=PREPLATE
BLANK-POSTPLATE

FORM
BLANK=CHAIN
1=CHAIN WITH INTERLEAF
PAPER ON REEL.
L=LOOSE

FINISH CODE

- NOTES:**
- MATERIAL: BRASS
 - FINISHES:
 - 901 HOT TIN DIP (.00051)/.000020 MIN.
 - * 228 SELECT GOLD PLATE (.00075)/.000030 MIN. IN CONTACT AREA, SELECT TIN (.00250)/.000100 MIN. IN CRIMP AREA OVER (.00125)/.000050 MIN. NICKEL OVERALL, WITH (.000010/(0.00025) MAX. SELECT GOLD FLASH IN AREA INDICATED.
 - 561 SELECT GOLD PLATE (.00076)/.000030 MIN. IN CONTACT AREA, (.00127)/.000050 MIN. NICKEL OVERALL.
 - 591 SELECT GOLD PLATE (.00127)/.000050 MIN. IN CONTACT AREA, OVER (.00127)/.000050 MIN. NICKEL OVERALL WITH (.00025)/.000010 MAX. GOLD FLASH OVERALL.
 - 550 SELECT GOLD PLATE (.00038)/.000015 MIN. IN CONTACT AREA, OVER (.00076)/.000030 MIN. NICKEL OVERALL WITH (.00025)/.000010 MAX. GOLD FLASH OVERALL.
 - THE PRIMARY SHIPPING CARTON WILL BE LABELED, *COMPLIANT TO RoHS DIRECTIVE 2002/95/EC AND ELV ANNEX II OF DIRECTIVE 2000/53/EC THIS LABEL MAY CONTAIN PRODUCT WITH TIN-LEAD.
 - PRODUCT SPECIFICATION: PS-02-0-6
 - PACKAGE INFORMATION: NOT AVAILABLE
 - TERMINAL FOR USE WITH (1.57)/.062 DIA. SERIES HOUSINGS AND WILL ACCEPT 24 THRU 30 AWG WIRE WITH (1.02/2.29)/.040/.090 INSULATION DIAMETER.

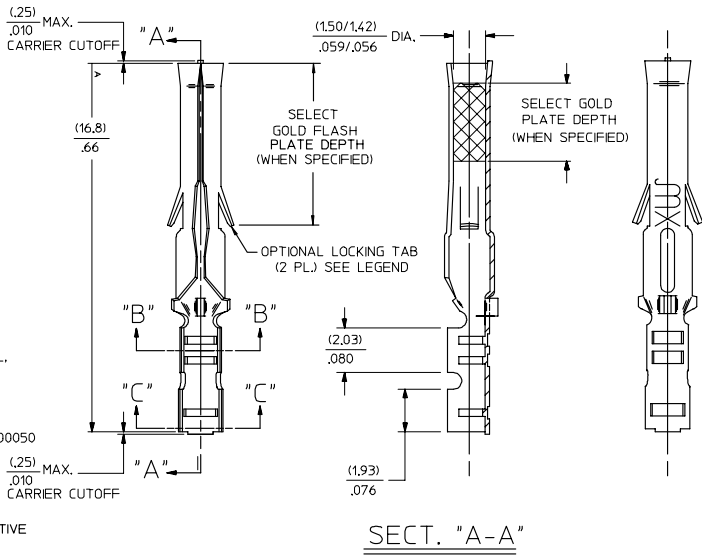

AP	REVISE S/N/PB PLATE REPAIR TO 45° UCP2004-209 5/07/04 RW/SLTS
AN	OBSOLETE P/N UCP2002-0276 COHER 01/9/28
AM1	OBSOLETE #0575 & #575L ECP 1/4 0368 GC/9/15/95 RW
AM	REV. AND REDRAWN PER ECR 0372 GEP 6-17-87 RW

REV. MATL. SPEC/STAT TO HEAD EC NO. UCP2004-2097 DRAWN: ROLTS 2004/05/14 CHKD: 2004/05/14 APPR: F SMITH 2004/05/18	QUALITY SYMBOLS 0 0	GENERAL TOLERANCES (UNLESS SPECIFIED)	SCALE 8:1	DESIGN UNITS INCH	THIRD ANGLE PROJECTION	REVISE ON CAD ONLY
		4 PLACES ± .005 ± .005 3 PLACES ± .005 ± .005 2 PLACES ± .025 ± .014 1 PLACE ± 0.35 ± .005	DIMENSION STYLE IN/MM	TITLE CRIMP TERMINAL, FEMALE (1.57)/.062 DIA., BRASS FOR 24 THRU 30 GA. WIRE		
DESCRIPTION	DRAFT WHERE APPLICABLE MUST REMAIN WITHIN DIMENSIONS	APPROVED BY RAS	DATE 1987/09/17	CHECKED BY RW	DATE 1987/09/17	MATERIAL NO. SEE CHART
						DOCUMENT NO. SD-1855-* SHEET NO. 1 OF 1

3.00mm (.118") Pitch Micro-Fit CPI™ Wire-to-Board Header

44914
Dual Row, Vertical

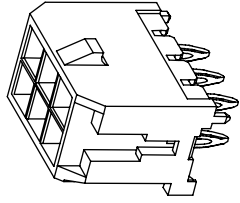

Features and Benefits

- Solderless board connection
- 2 to 24 circuits for design flexibility
- Fully isolated contacts prevent terminal damage
- Fully polarized to prevent mismatching

Reference Information

Product Specification: PS-43045
Packaging: Tray
UL File No.: E29179
CSA File No.: LR19980A
TUV File No.: R72040445
Mates With: 43025
Designed In: Millimeters

Electrical

Voltage: 250V
Current: 5.0A max.
Contact Resistance: 100 milliohms max.
Dielectric Withstanding Voltage: 1500V AC

Mechanical

Insertion Force to PCB: 10.9kgf max. (24 lbf) per terminal
Retention Force to PCB: 3.6kgf max. (8lbf) per terminal
Durability: 30 cycles

Physical

Housing: High-temperature LCP, UL 94V-0
Contact: Brass
Plating: Contact Area—Tin or Gold
Solder Tail Area—Tin or Tin/Lead
Underplating—Nickel
PCB Thickness: 2.34mm (.092") min.
Operating Temperature: -40 to +105°C

Power Connectors

E

Circuits	Order No.			Lead-free
	Tin	15µ" Gold	30µ" Gold	
2	44914-0201	44914-5202	44914-5203	Yes
4	44914-0401	44914-5402	44914-5403	
6	44914-0601	44914-5602	44914-5603	
8	44914-0801	44914-5802	44914-5803	
10	44914-1001	44914-6002	44914-6003	
12	44914-1201	44914-6202	44914-6203	
14	44914-1401	44914-6402	44914-6403	
16	44914-1601	44914-6602	44914-6603	
18	44914-1801	44914-6802	44914-6803	
20	44914-2001	44914-7002	44914-7003	
22	44914-2201	44914-7202	44914-7203	
24	44914-2401	44914-7402	44914-7403	

Circuits	Order No.		Lead-free
	15µ" Gold	30µ" Gold	
2	44914-0202	44914-0203	No
4	44914-0402	44914-0403	
6	44914-0602	44914-0603	
8	44914-0802	44914-0803	
10	44914-1002	44914-1003	
12	44914-1202	44914-1203	
14	44914-1402	44914-1403	
16	44914-1602	44914-1603	
18	44914-1802	44914-1803	
20	44914-2002	44914-2003	
22	44914-2202	44914-2203	
24	44914-2402	44914-2403	

1.57mm (.062") Pin Diameter .062" Pin and Socket Female Terminals

Standard .062"

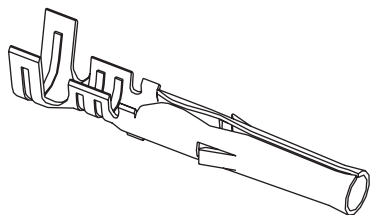

Features and Benefits

- Available in Tin or Gold platings
- Available in Brass or Phosphor Bronze base materials
- Accommodates 18 to 30 gauge wire

Reference Information

Packaging: Bag or reel
UL File No.: E29179
CSA File No.: LR19980
Designed In: Inches

Electrical

Contact Resistance: 3.2 milliohms max.
Current: 5.0A

Mechanical

Contact Insertion Force: 15.75N max.
Durability: Tin—25 cycles max.
Gold—50 cycles max.

Physical

Contact: Brass or Phosphor Bronze
Plating: Tin or Gold
Operating Temperature: -40 to +105°C

Type	Plating	Crimp Wire Size	Insulation Diameter	Series	Order No.		Lead-free	
					Chain	Loose		
Standard Brass .008"	Tin	18-24	1.52/3.05 (.060/.120)	1561	02-06-1101	02-06-1103	Yes	
		24-30	1.02/2.29 (.040/.090)	1855	02-06-1131	02-06-1132		
	15µ" Gold	18-24	1.52/3.05 (.060/.120)	1561	02-06-5100	02-06-5103		
		24-30	1.02/2.29 (.040/.090)	1855	02-06-5130	02-06-5135		
	30µ" Gold	18-24	1.52/3.05 (.060/.120)	1561	02-06-5101	02-06-5102		
		24-30	1.02/2.29 (.040/.090)	1855	02-06-5138	02-06-5139		
	30µ" Gold Contact Tin Crimp	18-24	1.52/3.05 (.060/.120)	1561	02-06-5108	02-06-5109		
		24-30	1.02/2.29 (.040/.090)	1855	02-06-5147	02-06-5148		
	Phos-Bronze	Tin .006"	18-24	1.52/3.05 (.060/.120)	4529	02-06-1104		02-06-1105
			18-24	1.52/3.05 (.060/.120)	1787	02-06-1201		02-06-1202
.006" Gold (15µ")		18-24	1.52/3.05 (.060/.120)	2189	02-06-1231	02-06-1232		
		18-24	1.52/3.05 (.060/.120)	4529	02-06-5207	02-06-5208		
.008" Gold (15µ")		18-24	1.52/3.05 (.060/.120)	1787	02-06-5201	02-06-5202		
.008" PC Tail Brass for Standard .062" Housings Only	Tin			1779		02-06-7103		
	30µ" Gold Tin Tail Area			1779		02-06-7104		

Note: .006 Phosphor Bronze stock recommended for versions 15 circuits and larger

E-104 MX07

