

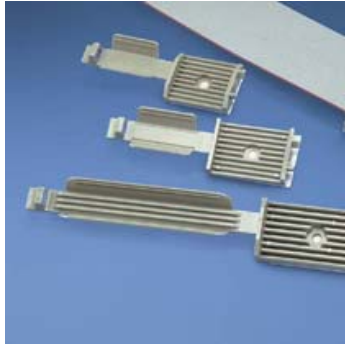

FCM1.2-A-C14



- Four sizes each with a stack height of .17" (4.3mm) to accommodate different flat cable widths. All sizes are available with adhesive backing or can be screw applied.

• Part Number	FCM1.2-A-C14
• RoHS Compliancy Status	Compliant
• Part Description	Adhesive Backed Latching Flat Cable Holder
• Product Type	Mounting Device
• Material	Nylon 6.6
• Color	Gray
• UL Recognized	E136577
• Length (In.)	3.16
• Length (mm)	80.3
• Width (In.)	1.37
• Width (mm)	34.8
• Adhesive Type	Rubber Adhesive
• Cable Width (In.)	1.20
• Cable Width (mm)	30.5
• Environment	Indoors
• Max. Flat Cable Width (In.)	1.20
• Max. Flat Cable Width (mm)	30.5
• Max. Static Load (g)	281
• Max. Static Load (Lbs.)	.62
• Mounting Method	Rubber Adhesive
• Pricing Description	Flat Cable Mount, Adh., 1.20" (30.5mm) W Cable
• Screw Size	#6 (M3)
• Screw Size Metric	M3
• Min. Order UOM	PC
• Min. Order Qty.	100

THIS COPY IS PROVIDED ON A RESTRICTED BASIS AND IS NOT TO BE USED IN ANY WAY DETRIMENTAL TO THE INTERESTS OF PANDUIT CORP.

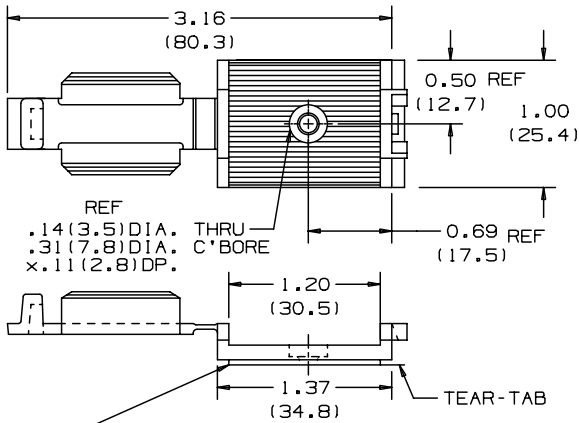

ADHESIVE TAPE: PRESSURE SENSITIVE FOAM 0.040 (1.02) THICK WITH RUBBER ADHESIVE AND PROTECTIVE LINER. MOUNT IS DESIGNED TO SUPPORT 0.62 lbs. (281g) MAXIMUM WEIGHT ON A CLEAN, DRY, SMOOTH, GREASE-FREE SURFACE.

NOTES:

1. SEE CURRENT PRICE SHEET FOR PART NUMBER SUFFIX DESIGNATION FOR PACKAGE SIZE AND PART COLOR.
2. TO APPLY MOUNT: a) REMOVE PROTECTIVE LINER; b) PLACE IN DESIRED LOCATION; c) APPLY PRESSURE TO TOP OF MOUNT.

PANDUIT PART No.	REC'M. SCREW FASTENER	WEIGHT lbs. (g)/100PCS.
FCM1.2-A	N/A	0.96 (436)
FCM1.2-S6	#6 (M3) FL.HD. OR BUTTON HD.	0.91 (413)

NO WARRANTY, EXPRESSED OR IMPLIED, IS MADE BY PANDUIT WITH RESPECT TO ADHESIVE BOND PERFORMANCE. AMONG OTHER THINGS, THE CONDITIONS UNDER WHICH THESE MOUNTS MAY BE APPLIED AND/OR THE SURFACE TO WHICH THEY MAY BE APPLIED ARE BEYOND PANDUIT'S CONTROL.

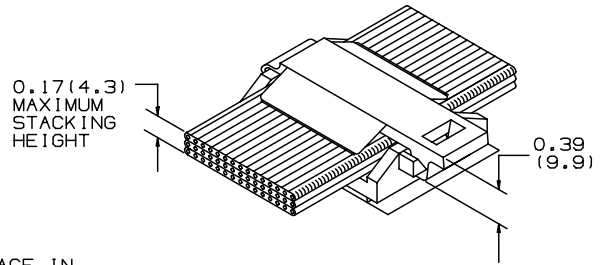

(DIMENSIONS IN PARENTHESES ARE IN METRIC.)

CAD FILENAME/LAYERS G002391F_P1_FCM1.2_00

PANDUIT CORP. TINLEY PARK, ILLINOIS

1.2 INCH FLAT CABLE MOUNT FCM1.2

UNLESS OTHERWISE SPECIFIED, DIMENSIONAL TOLERANCES ARE:
 (.X) ± NA (.XXX) ± NA
 (.XX) ± 0.020 (1.5) ANGLES ± NA

UNLESS OTHERWISE SPECIFIED, ALL DIMENSIONS ARE GIVEN IN INCHES, THIRD ANGLE PROJECTION.

DRAWN BY LGG

MAT'L:

SCALE

FULL

REV	DATE	BY	CHK	DESCRIPTION	ECN	R	CUST	SUP
R	6/22/01	LGG		INITIAL RELEASE REPLACED SS-19058	GB02391F	R		

DATE 6/22/01

NYLON 6/6

DRAWING NO.

GB02391F

DWG

A

SIZE