

Part Number: [0008050302](#)
Status: **Active**
Overview: [KK®](#)
Description: [KK® Crimp Terminal, Series 4366, Female, with Selective Gold \(Au\) Plated Brass Contact, 18-24 AWG, Bag](#)

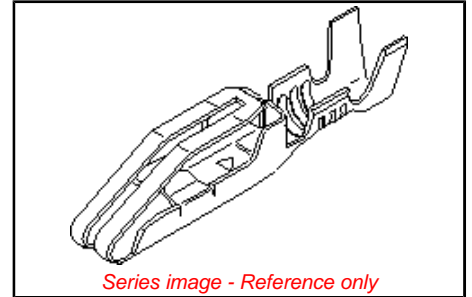

General

Product Family	Crimp Terminals
Series	4366
Overview	KK®
Product Name	KK®

Physical

Gender	Female
Material - Metal	Brass
Material - Plating Mating	Gold
Material - Plating Termination	Nickel
Packaging Type	Bag
Plating min: Mating (µin)	15
Plating min: Mating (µm)	0.38
Plating min: Termination (µin)	30
Plating min: Termination (µm)	0.75
Termination Interface: Style	Crimp or Compression
Wire Insulation Diameter	2.79mm (.110") max.
Wire Size AWG	18
Wire Size AWG	20
Wire Size AWG	22
Wire Size AWG	24
Wire Size mm²	N/A

Material Info

Old Part Number	4366-P555L
-----------------	------------

EU RoHS
ELV and RoHS
Compliant

China RoHS



13 12 11 10 9 8 7 6 5 4366 4 3 2 1

J
I
H
G
F
E
D
C
B
A

J
I
H
G
F
E
D
C
B
A

NOTES

- MATERIAL: BRASS, ALLOY 260, .010/(0.25) THICK.
- FINISH:
 - P555: .00015/(0.00038) MIN. SELECT GOLD OVER .00030/(0.00076) MIN. NICKEL OVERALL.
 - P913: .000100/(0.00254) - .000250/(0.00635) HOT TIN-LEAD DIP.
 - P607: .000050/(0.00127) MIN. SELECT GOLD OVER .000050/(0.00127) MIN. NICKEL OVERALL.
 - P228: .000030/(0.00076) MIN. SELECT GOLD ON CONTACT AREA. .000100/(0.00254) MIN. SELECT MATTE TIN, BOTH OVER .000050/(0.00127) MIN. NICKEL OVERALL.
- PRODUCT SPECIFICATION PS-09-50 APPLIES.
- TERMINAL FOR USE WITH 18-24 AWG WIRE.
- THIS PART CONFORMS TO CLASS B REQUIREMENTS OF COSMETIC SPEC. PS-45499-002.

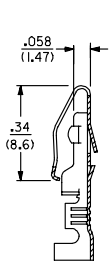

SECTION A-A

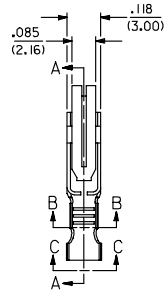

SECTION B-B

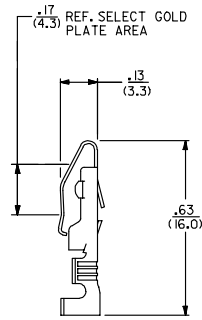

LEGEND

4366-**-**
 PLATING (SEE NOTE 2) FORM
 BLANK=CHAIN
 L=LOOSE

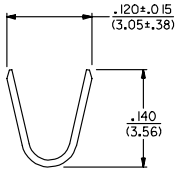

VIEW C-C

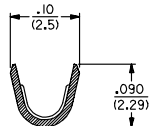

2	C1
1	C1
SHT.	REV.

ADD P228 FINISH EC NO. UCP2007-3134 DRAWN BY 2007/06/13 CHECKED BY 2007/06/18 APPROVED BY 2007/06/19 REV DESCRIPTION	QUALITY SYMBOLS ▽=0 ▽=0	GENERAL TOLERANCES (UNLESS SPECIFIED) mm INCH 4 PLACES ± --- ± --- 3 PLACES ± --- ± .010 2 PLACES ± 0.25 ± .014 1 PLACE ± 0.35 ± --- ANGULAR ±1/2°	DIMENSION STYLE IN/MM DRAWN BY DATE ROBERTS 1991/08/15 CHECKED BY DATE PATEL 1991/08/15 APPROVED BY DATE LENZ 1991/08/15	SCALE 4:1 DESIGN UNITS INCH THIRD ANGLE PROJECTION	TITLE TERMINAL CRIMP ON
	MATERIAL NO. SD-4366 DOCUMENT NO. SHEET NO. 1 OF 2	MOLEX INCORPORATED THIS DRAWING CONTAINS INFORMATION THAT IS PROPRIETARY TO MOLEX INCORPORATED AND SHOULD NOT BE USED WITHOUT WRITTEN PERMISSION			

12 11 10 9 8 7 6 5 4 3 2 1

COLUMN NO. 1			COLUMN NO. 2			COLUMN NO. 3			COLUMN NO. 4		
PART NO.	ENG. NO.	REF.	PART NO.	ENG. NO.	REF.	PART NO.	ENG. NO.	REF.	PART NO.	ENG. NO.	REF.
08-03-0304	4366-P913L										
08-03-0303	4366-P913										
08-05-0302	4366-P555L	ES-150-*									
08-05-0301	4366-P555	ES-150-*									
08-05-0305	4366-P607	ES-150-*									
50-36-1873	4366-P228	ES-150-*									

COLUMN NO. 1	CON'T. IN COLUMN NO.	SHEET NO.	COLUMN NO. 2	CON'T. IN COLUMN NO.	SHEET NO.	COLUMN NO. 3	CON'T. IN COLUMN NO.	SHEET NO.	COLUMN NO. 4	CON'T. IN COLUMN NO.	SHEET NO.																					
ADD P/N 50-36-1873			EC NO. UCP2007-3134 2007/06/13 DRWNSKI PPR 2007/06/18 CHACADER 2007/06/18 APPRESMITH 2007/06/19			QUALITY SYMBOLS ▽=0 ▽=0			GENERAL TOLERANCES (UNLESS SPECIFIED) <table border="1"> <tr> <td></td> <td>mm</td> <td>INCH</td> </tr> <tr> <td>4 PLACES</td> <td>±---</td> <td>±---</td> </tr> <tr> <td>3 PLACES</td> <td>±---</td> <td>±---</td> </tr> <tr> <td>2 PLACES</td> <td>±---</td> <td>±---</td> </tr> <tr> <td>1 PLACE</td> <td>±---</td> <td>±---</td> </tr> </table> ANGULAR ±1/2°				mm	INCH	4 PLACES	±---	±---	3 PLACES	±---	±---	2 PLACES	±---	±---	1 PLACE	±---	±---	DIMENSION STYLE IN/MM DRAWN BY ROBERTS DATE 1991/08/28 CHECKED BY DATE PATEL 1991/08/28 APPROVED BY LENZ DATE 1991/08/28			SCALE --- DESIGN UNITS INCH THIRD ANGLE PROJECTION		
	mm	INCH																														
4 PLACES	±---	±---																														
3 PLACES	±---	±---																														
2 PLACES	±---	±---																														
1 PLACE	±---	±---																														
DRAFT WHERE APPLICABLE MUST REMAIN WITHIN DIMENSIONS			MATERIAL NO. SEE CHART			DOCUMENT NO. SD-4366			SHEET NO. 2 OF 2																							
THIS DRAWING CONTAINS INFORMATION THAT IS PROPRIETARY TO MOLEX INCORPORATED AND SHOULD NOT BE USED WITHOUT WRITTEN PERMISSION																																

3.96mm (.156") Pitch Double-Sided Edge KK[®] Connector Terminals

4366 PC Crimp and Solder Eyelet

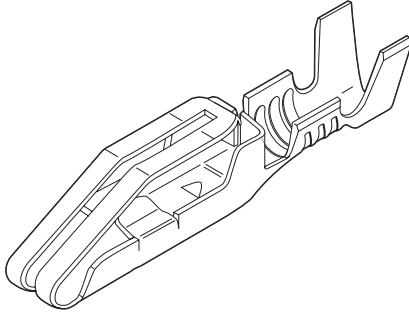

Features and Benefits

- Solder loop version available
- Anti-fishhooking feature prevents terminals from snagging
- Wire barrier prevents stripped wire from entering the contact area
- Coined outside edges prevent excess scoring of the solder pad surfaces
- Patented bifurcated contact area
- Anti-overstress feature

Reference Information

Packaging: Reel or bag
Use With: 4338
Designed In: Inches

Electrical

Voltage: 250V
Current: 5.0A
Contact Resistance: 20 milliohms max.
Dielectric Withstanding Voltage: 1500V
Insulation Resistance: 50,000 Megohms min.

Mechanical

Contact Retention to Housing: 8 lb min.
Wire Pull-Out Force: 20 lb for 18 AWG
(less for smaller wire)

Physical

Contact: Brass
Plating: See Table
Operating Temperature: 0 to +75°C

Order No.		Crimp Wire Size	Maximum Insulation Diameter	Engineering No.	Plating	Lead-free
Reel Form	Bag Form					
08-03-0303	08-03-0304	18-20	2.79 (.110)	4366	Tin	Yes
08-05-0301	08-05-0302			4366	Gold	

L 3.96mm (.156") Pitch KK[®] Crimp Terminal

2478/2578

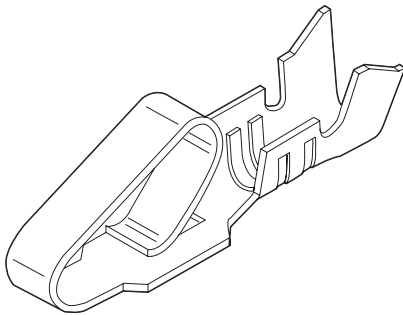

Features and Benefits

- Double cantilever design
- Single beam terminal is available for low insertion force 7821 Series (contact Molex)
- For low-level current and voltage, use Gold plating
- Phosphor Bronze is recommended for rated current
- Complete line of terminal crimping equipment available (see Application Tooling section of this catalog)

Reference Information

Product Specification: PS-08-50
Packaging: Reel or bag
Tooling Information: See crimp tooling section
UL File No.: E29179
CSA File No.: LR19980
Use With: 2139, 3069 and 41695
Designed In: Inches

Electrical

Voltage: 250V AC max.
Current: Max.

AWG	18	20	22	24	26
Phosphor Bronze	7.00A	6.25A	5.50A	5.00A	4.50A
Brass	5.00A	4.75A	4.50A	4.25A	4.00A

Contact Resistance: 6 milliohms max.
Dielectric Withstanding Voltage: 1500V AC
Insulation Resistance: 50K Megohms min.

Mechanical

Contact Insertion Force: 1.8kg (4 lb) max.
Contact Retention to Housing: 3.6kg (8 lb) min.
Wire Pull-Out Force: 20 lb max./18 AWG
Normal Force: 0.75kg (1.65 lb)
Durability: 25 cycles max.

Physical

Contact: Brass or Phosphor Bronze
Plating: See Table
Operating Temperature: Phosphor Bronze—0 to +75°C
Brass—0 to +50°C

Order No.						Wire Size AWG	Insulation OD	Series	Material	Lead-free
Tin Plating		Gold Plating No. 1		Gold Plating No. 2						
Reel	Bag	Reel	Bag	Reel	Bag					
08-52-0071	08-52-0072	08-58-0121	08-58-0122	08-65-0114	08-65-0115	18-20	2.79 (.110)	max. 2478	Phosphor Bronze	Yes
08-50-0105	08-50-0106	08-56-0105	08-56-0106	08-55-0103	08-55-0104	18-20	2.79 (.110)	max. 2478	Brass	
08-50-0133	08-50-0134	08-58-0125	08-58-0126	08-65-0116	08-65-0117	22-26	1.65 (.065)	max. 2578	Phosphor Bronze	
08-50-0107	08-50-0108	08-56-0107	08-56-0108	08-55-0105	08-55-0106	22-26	1.65 (.065)	max. 2578	Brass	

Recommended wire range assumes stranded wire
Plating No. 1: 20µm min. Gold in contact area with a flash overall
Plating No. 2: 15µm min. Gold in contact area only