

Current refinements (click to remove)

[Search Tips](#) 
 [Region](#) **USA** [Product Family](#) **Ring Terminal, Nylon Insulated** [Text Search](#): 'PN18-10R-C'

Your search criteria matched only one product, shown below.

- Ring tongue design assures a secure connection in high vibration applications
- Metal insulation grip sleeve crimps to wire insulation, providing protection to the crimp joint during high vibration applications
- Internal barrel serrations assure good wire contact and maximum tensile strength
- UL Flammability UL 94V-2/HB, maximum insulation temperature 221°F (105°C)
- UL and CSA rated up to 600 V per UL 486

‡UL and CSA approved tooling/product combinations.

Note: Wire sizes #26 – #22 AWG, are not UL Listed or CSA Certified.

Related Products
[Hand Operated Plier Type Tools](#)
[Contour Crimp™ Control...](#)
[Pneumatic Crimping Tool](#)

Part Number:	PN18-10R-C
RoHS Compliancy Status:	Compliant
Part Description:	Ring Terminal, 22 – 18 AWG, #10 stud size, nylon insulated.
Product Type:	Terminals
CSA Certified:	Yes
Mil. Std. Part Number:	MS25036-103 (Class 1 & 2)
UL Listed:	Yes
Length (In.):	.88
Length (mm):	22.4
Width (In.):	.31
Width (mm):	7.9
Clearance:	.25
Max. Ins.:	.145
Panduit Color Code:	Red
Stock:	.03
Stud Size:	#10
Tool:	CT-100A‡, CT-600-A‡, CT-1550‡, CT-1551‡, CT-2500‡
Wire Range:	22 – 18 AWG
Min. Order UOM:	PC
Min. Order Qty.:	100
BOM Qty. (# of Pkgs.)	

[Add to My Catalog](#)

 Please [register](#) to utilize the 'Bill of Materials', 'Submit Quotes' and 'My Catalog' features.

THIS COPY IS PROVIDED ON A RESTRICTED BASIS AND IS NOT TO BE USED IN ANY WAY DETRIMENTAL TO THE INTERESTS OF PANDUIT CORP.

PANDUIT PART NUMBER PREFIX	PK	MILITARY PART NO. AND CLASS	STUD SIZE	DIMENSIONS in.				
				A $\pm .03$	W $\pm .01$	C $\pm .02$	G $\pm .03$	H $\pm .01$
PN18-4R	-C -M	-----	#4	.80 (20.3)	.25 (6.4)	.22 (5.6)	.67 (17.0)	.12 (3.1)
PN18-4RN	-C -M	MS25036-148 CLASS 1 & 2	#4	.74 (18.8)	.22 (5.6)	.18 (4.6)	.63 (16.0)	.12 (3.1)
PN18-6R	-C -M	MS25036-102 CLASS 1 & 2	#6	.80 (20.3)	.25 (6.4)	.22 (5.6)	.67 (17.0)	.15 (3.8)
PN18-6RN	-C -M	MS25036-101 CLASS 1 & 2	#6	.77 (19.6)	.22 (5.6)	.18 (4.6)	.63 (16.0)	.15 (3.8)
PN18-8R	-C -M	MS25036-149 CLASS 1 & 2	#8	.86 (21.8)	.31 (7.9)	.25 (6.4)	.70 (17.8)	.17 (4.3)
PN18-10R	-C -M	MS25036-103 CLASS 1 & 2	#10	.88 (22.4)	.31 (7.9)	.25 (6.4)	.70 (17.8)	.20 (5.1)
PN18-14R	-C -M	MS25036-150 CLASS 1 & 2	1/4"	1.09 (27.7)	.45 (11.4)	.38 (9.7)	.80 (20.3)	.27 (6.9)
PN18-56R	-C -M	MS25036-104 CLASS 1 & 2	5/16"	1.09 (27.7)	.46 (11.7)	.38 (9.7)	.84 (21.8)	.33 (8.4)
PN18-38R	-C -M	MS25036-105 CLASS 1 & 2	3/8"	1.17 (29.7)	.53 (13.5)	.43 (10.9)	.91 (23.1)	.39 (9.9)
PN18-12R	-C	-----	1/2"	1.35 (34.3)	.72 (18.3)	.53 (13.5)	.99 (25.1)	.52 (13.2)

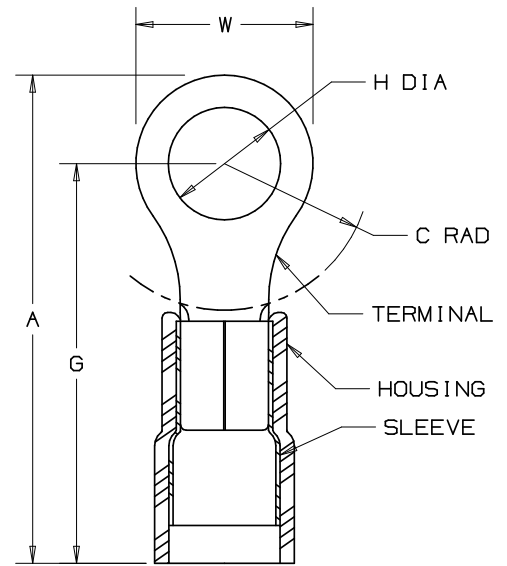

NOTES:

- 1) UL LISTED AND CSA CERTIFIED FOR:
 - A. 600V. MAX. BLDG. WIRE (1000V. MAX. IN SIGNS, FIXTURES & LUMINARIES)
 - B. 221°F. (105°C) MAX. TEMP. RATING
 - C. #22-18 AWG (0.5-1.5mm²) SOLID OR STRANDED COPPER WIRE.
- 2) MATERIAL:
 - A. STAMPING- .032" (.81) THK. COPPER, TIN PLATED
 - B. HOUSING- NYLON, RED
 - C. SLEEVE- BRASS, TIN PLATED
- 3) WIRE STRIP LENGTH- 7/32" +1/32, -0 (5.6, +.8, -0)
- 4) PACKAGE QUANTITY: -C = 100, -M = 1000

5) DIMENSIONS IN PARENTHESIS ARE IN MILLIMETERS

- 6) INSTALLATION TOOLS:
 - A. UL LISTED AND CSA CERTIFIED: CT-100*, CT-400*, (UL, MIL CLASS 2), CT-500*, CT-550*, CT-1550*, CT-1551*
 - B. PANDUIT APPROVED: CT-160*, CT-250*
*APPROVED FOR EXPANDED WIRE RANGE #22-16 AWG

Panduit part numbers shown on this drawing meet the material requirements of RoHS (EUROPEAN DIRECTIVES 2002/95/EC) as proposed by the Technical Adaptation Committee



A41543_09

PANDUIT CORP.

TINLEY PARK, ILLINOIS

3PC. NYLON INSULATED 22-18 BARREL, RING TERMINALS

DRAWN BY: **BDK** CHK'D: **LA** SCALE: **NONE** DRAWING NO.: **A41543**

REV	DATE	BY	CHK	DESCRIPTION	ECN #	CUST	PM
09	12/06	DAW	DAW	RED NYLON WAS INCORRECTLY LISTED AS BLUE IN NOTE 2, LINE B.	TR00188	LCA	TRO
08	8/06	DAW	DAW	ADDED MILITARY PART NO. & CLASS	TR00155	LCA	TRO
07	12/02	SAC	SKB	FOR PN18-12R DIM A WAS 1.34 & DIM G WAS .98 & MADE ALL METRIC DIMS ONE PLACE	10504	LA	TRO
06	11/02	SAC	SKB	ADDED NOTE 3	10489	LA	TRO
05	10/02	SAC	SKB	CHANGED DIM. M TO DIM. G	10480	LA	TRO