



Series image - Reference only

EU RoHS	China RoHS
ELV and RoHS Compliant	
Search Parts in this Series 19164 Series	
Application Tooling	
Global	
Description	Product #
Hand Crimp Tool, UL Approved	0640017400

Part Number: **0191640086**

Status: **Active**

Description: Perma-Seal™ Ring Tongue Terminal for 18-22 AWG Wire, Stud Size 8

Documents:

- [Drawing \(PDF\)](#)
- [Product Literature \(PDF\)](#)
- [Related Catalog Page \(PDF\)](#)

Order Products:

- [Check Distributor Inventory](#)
- [Request Samples](#)

Part Detail: [\(show all\)](#)

○ **General**

○ **Physical**

○ **Electrical**

○ **Material Info**

General

Product Family	Ring and Spade Terminals
Series	19164
Material - Plating Mating	Tin
Mil-Spec	N/A
Product Name	Perma-Seal™
Type	Ring

Physical

Barrel Type	Closed
Flammability	94 V2
Insulation	NiAc(TM)
Material - Metal	Copper
Packaging Type	Box
Stud Size	8 (M4)
Wire Insulation Diameter	5.97mm (.235")
Wire Size AWG	18
Wire Size AWG	20
Wire Size AWG	22
Wire Size mm ²	0.38 - 0.96

Electrical

CSA	LR18689
UL	E32244

Material Info

Old Part Number	SA-221-08
-----------------	-----------

MATERIAL NUMBER	ENGINEERING NUMBER	MATERIAL NUMBER ON TAPE	ENGINEERING NUMBER ON TAPE	STUD SIZE	HOLE "S" ± 0.005 ± 0.03	"D" MAX	"H" ± 0.10 ± 0.25	"L" MAX	"T" REF	ID MIN
191640085	SA-221-06	---	---	#6	$\varnothing .146/3.71$	$\varnothing .32/8.1$	---	1.46/37.1	.028/0.71	.064/1.63
191640086	SA-221-08	191640419	SA-221-08T	#8	$\varnothing .173/4.39$	$\varnothing .32/8.1$.534/13.56	1.46/37.1	.028/0.71	.064/1.63
191640003	SA-221-10	191640306	SA-221-10T	#10	$\varnothing .198/5.03$	$\varnothing .32/8.1$.534/13.56	1.46/37.1	.028/0.71	.064/1.63
191640004	SA-222-14	191640844	SA-222-14T	1/4	$\varnothing .265/6.73$	$\varnothing .48/12.2$.340/8.65	1.66/42.2	.028/0.71	.055/1.40
191640005	SA-226-38	191640845	SA-226-38T	3/8	$\varnothing .390/9.91$	$\varnothing .54/13.7$.328/8.33	1.95/49.5	.032/0.81	.055/1.40

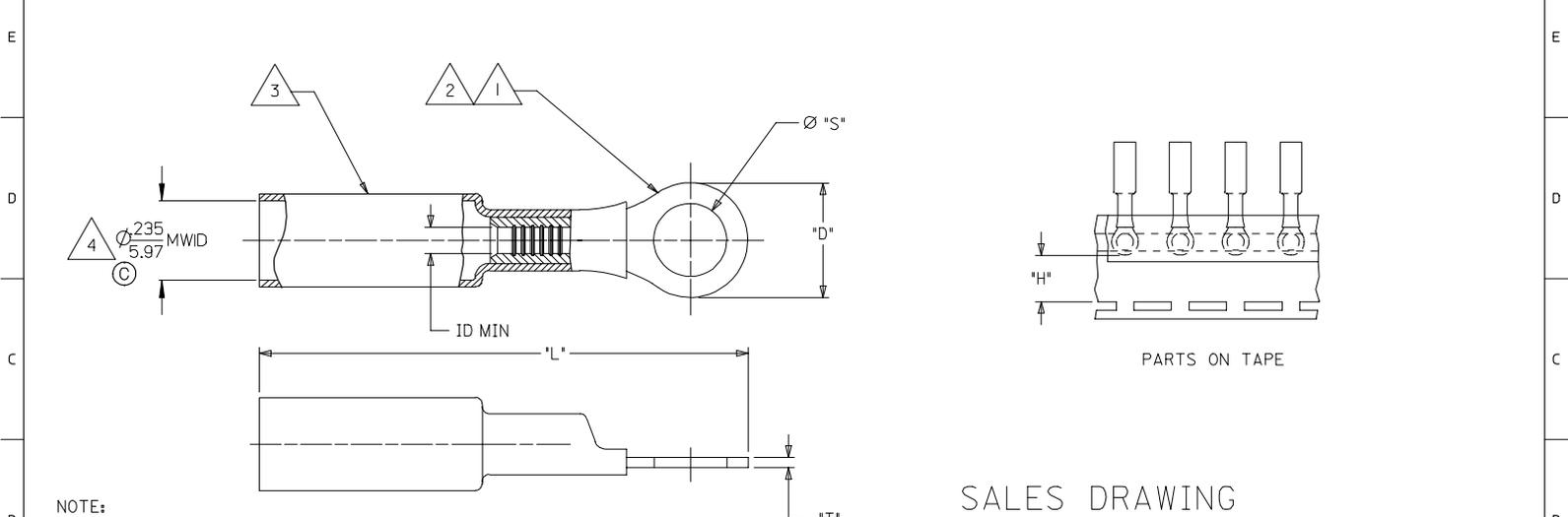

- NOTE:
- 1. TERMINAL MATERIAL: COPPER ALLOY
 - 2. FINISH: ELECTRO TIN PLATE.
 - 3. INSULATION MATERIAL: HEAT SHRINKABLE TUBING WITH HOTMELT ADHESIVE INNER LINER. COLOR: RED.
 - 4. MWID = MAXIMUM WIRE INSULATION DIAMETER.

SALES DRAWING

CHANGED MWID EC NO: ETC2006-0154 DRAWN BY: DR. N. S. VIDYAR 2005/12/21 CHKD: J. COMASTRO 2005/12/21 APPR: J. PAMILLER 2005/12/21	QUALITY SYMBOLS	GENERAL TOLERANCES (UNLESS SPECIFIED)	DIMENSION STYLE	SCALE	DESIGN UNITS	THIRD ANGLE PROJECTION																											
	$\nabla = 0$ $\sphericalangle = 0$	<table border="1"> <tr> <th></th> <th>mm</th> <th>INCH</th> </tr> <tr> <td>4 PLACES</td> <td>$\pm .13$</td> <td>$\pm .005$</td> </tr> <tr> <td>3 PLACES</td> <td>± 0.25</td> <td>$\pm .010$</td> </tr> <tr> <td>2 PLACES</td> <td>$\pm .50$</td> <td>$\pm .020$</td> </tr> <tr> <td>1 PLACE</td> <td>± 1.00</td> <td>$\pm .040$</td> </tr> </table>		mm	INCH	4 PLACES	$\pm .13$	$\pm .005$	3 PLACES	± 0.25	$\pm .010$	2 PLACES	$\pm .50$	$\pm .020$	1 PLACE	± 1.00	$\pm .040$	IN/MM	---	INCH	<table border="1"> <tr> <th>DRAWN BY</th> <th>DATE</th> </tr> <tr> <td>BENDERLE</td> <td>2005/5/14</td> </tr> <tr> <th>CHECKED BY</th> <th>DATE</th> </tr> <tr> <td>HBEITZEL</td> <td>2005/5/14</td> </tr> <tr> <th>APPROVED BY</th> <th>DATE</th> </tr> <tr> <td>RDEROSS</td> <td>2005/5/14</td> </tr> </table>	DRAWN BY	DATE	BENDERLE	2005/5/14	CHECKED BY	DATE	HBEITZEL	2005/5/14	APPROVED BY	DATE	RDEROSS	2005/5/14
		mm	INCH																														
	4 PLACES	$\pm .13$	$\pm .005$																														
3 PLACES	± 0.25	$\pm .010$																															
2 PLACES	$\pm .50$	$\pm .020$																															
1 PLACE	± 1.00	$\pm .040$																															
DRAWN BY	DATE																																
BENDERLE	2005/5/14																																
CHECKED BY	DATE																																
HBEITZEL	2005/5/14																																
APPROVED BY	DATE																																
RDEROSS	2005/5/14																																
DRAFT WHERE APPLICABLE MUST REMAIN WITHIN DIMENSIONS	MATERIAL NO. SEE CHART	DOCUMENT NO. SD-19164-006	RING TONGUE TERMINAL PERMA-SEAL NIAC 22-18 AWG	MOLEX INCORPORATED	STEEL NO. 1 OF 1																												
THIS DRAWING CONTAINS INFORMATION THAT IS PROPRIETARY TO MOLEX INCORPORATED AND SHOULD NOT BE USED WITHOUT WRITTEN PERMISSION																																	