

Series image - Reference only

EU RoHS	China RoHS
ELV and RoHS Compliant	

Search Parts in this Series

[19070 Series](#)

Application Tooling

Global

Description	Product #
Crimp Head for the AT-200™ Pneumatic Hand Tool	0640050300
Crimp Head for the AT-200™ Pneumatic Hand Tool	0640050100
Hand Crimp Tool	0640010100
Hand Crimp Tool	0640010300
Hand Crimp Tool	0640011500

Part Number: **0190700132**

Status: **Active**

Description: InsulKrimp™ Ring Tongue Terminal for 10-12 AWG Wire

Documents:

- [Drawing \(PDF\)](#)
- [Product Specification PS-19902-009 \(PDF\)](#)
- [Related Catalog Page \(PDF\)](#)

Order Products:

- [Check Distributor Inventory](#)
- [Request Samples](#)

Part Detail: (show all)

- **General**
- **Physical**
- **Electrical**
- **Material Info**
- **Reference - Drawing Numbers**

General

Product Family	Ring and Spade Terminals
Series	<u>19070</u>
Color - Resin	Natural
Material - Plating Mating	Tin
Mil-Spec	N/A
Product Name	InsulKrimp™
Type	Ring

Physical

Barrel Type	Closed
Flammability	94 V2
Insulation	PVC
Material - Metal	Copper
Material - Resin	PVC
Packaging Type	Box
Stud Size	1/4" (M6)
Wire Insulation Diameter	6.40mm (.250") max.
Wire Size AWG	10
Wire Size AWG	12
Wire Size mm ²	3.30 - 5.00

Electrical

CSA	LR18689
UL	E32244

Material Info

Old Part Number	C-230-14X
-----------------	-----------

Reference - Drawing Numbers

Product Specification	PS-19902-009
Sales Drawing	CCD20101

NOTES: ±.001

- ① MAT'L: COPPER(STOCK TKN. $\frac{.040}{1.02}$)
- PLATING: ELECTRO-TIN (.0003 MIN.)
- ② INSULATION: MOLDED PVC (YELLOW)

STUD SIZES: ($\pm .005$)

02 = .094	209=209
04 = .119	413=413
06 = .146	
08 = .173	
10 = .198	
14 = .265	
56 = .328	
38 = .390	
76 = .453	
12 = .515	

"UL" LISTING # E32244
 "CSA" LISTING # 18689

ALL DIMENSIONS = $\frac{\text{INCHES}}{\text{MM}}$

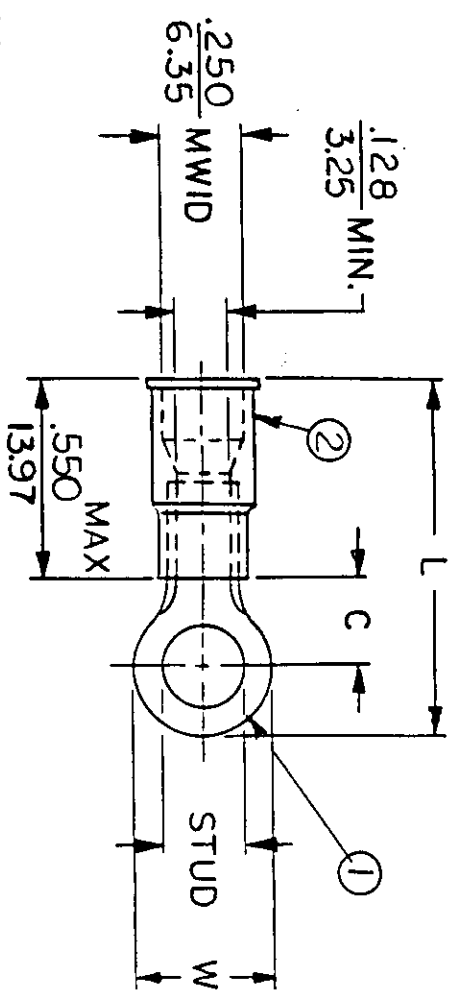

MWID = MAXIMUM WIRE
 INSULATION DIAMETER
 WIRE SIZE: 12-10 AWG
 40-60 MM²

FILE NO. C-CD-201-01

PART NUMBER	"W" ±.010	"C" MIN.	"L" MAX.	AVAILABLE STUD SIZES
C-201-	$\frac{.750}{19.05}$	$\frac{.611}{15.52}$	$\frac{1.571}{39.90}$	14X, 56X, 38X, 76X, 12X
C-228-	$\frac{.375}{9.53}$	$\frac{.303}{7.70}$	$\frac{1.076}{27.33}$	04X, 06X, 08X, 10X, 209X
C-230-	$\frac{.530}{13.46}$	$\frac{.393}{9.98}$	$\frac{1.243}{31.57}$	10X, 14X, 56X, 38X
C-236-	$\frac{.282}{7.16}$	$\frac{.306}{7.77}$	$\frac{1.032}{26.21}$	04X, 06X, 08X
C-240-	$\frac{.592}{15.04}$	$\frac{.466}{11.84}$	$\frac{1.347}{34.21}$	10X, 14X, 56X, 38X, 209X, 413X

DIMENSIONAL TOLERANCES UNLESS OTHERWISE SPECIFIED		REFERENCE	SCALE: NTS	DATE	TITLE:
FRAC.	DEC.	ANG.	DRWN. BY: JJ	10-31-84	RING TONGUE TERMINAL
±	±	±	CHKD. BY: GZ	11-26-84	INSULKRIMP 200-SERIES
			APPRD. BY:		



DWG. NO. A CUSTOMER DWG.