

Datasheet Crimp Terminals

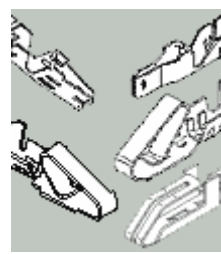

[[Home](#) > [Products](#) > [Crimp Terminals](#) > Datasheet]

39-00-0039

Mini-Fit™ Crimp Terminal 5556, 18-24 AWG, Bag, Brass, Tin (Sn)

View all parts in series
[5556](#)

[2D
Dimensions](#)

[E-mail this
page](#)

[Samples](#)

[Buy](#)

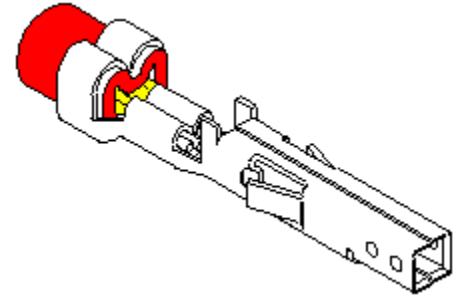

Status	Active
Access Level	Internet
Product Name	Mini-Fit™
Molex Series	5556
Gender	Female
Wire Size [AWG]	18, 20, 22, 24
Wire Insulation Diameter	1.30-3.10mm (.051-.122")
Packaging	Bag

PHYSICAL

Contact	Brass (CuZn)
Plated	Pre
Plating Contact	Tin (Sn)
Plating in Crimp Area	Tin (Sn)
Under Plating	Copper (Cu)
Plating Thickness	2.5µm (100µ")

REFERENCE

990 Catalog Page	K-53
MX01 Catalog Page	F-37
Old Part Number	5556TL
Product Management	Killian, Pat
Lab Office	J
Customer Approved	Compaq, Ford, Hewlett Packard, IBM, Lucent Technologies Inc, Matsushita Electric Industrial, Nortel Networks, Siemens, Sony

This part is
**ELV and RoHS
COMPLIANT**

ENVIRONMENT

[RoHS Compliant](#) Yes

Features and Benefits

- Crimp terminal for use in all Mini-Fit, Jr.™, Mini-Fit, BMI™ and Mini-Fit, TPA™ receptacle housings
- Four gas-tight points of contact

Related Products

APPLICATION TOOLING

Region	Description	Product Number
Americas	Hand Crimper	11-01-0197
Americas	Extraction Tool	11-03-0044
Asia	Handtool (Straight Action)	57022-5500
Asia	Hand Crimp Tool	57026-5000
Asia	Hand Crimp Tool	57027-5000
Asia	Hand Extraction Tool	57031-6000
Europe	Parallel Action Handtool for 5556/5558 Terminals	69008-0724
Europe	Extraction Tool	69008-1011

2D D R A W I N G - For reference only. See technical [Drawing \(PDF\)](#) for design-in purposes.

DIMENSIONS

Contact Material Thickness	0.20mm (.008")
Dimension C	3.60mm (.142")
Dimension D	4.50mm (.177")

Dimension E	1.90mm (.075")
Dimension F	2.30mm (.091")

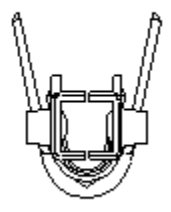
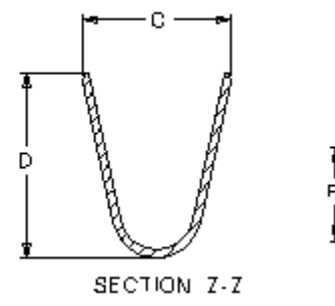
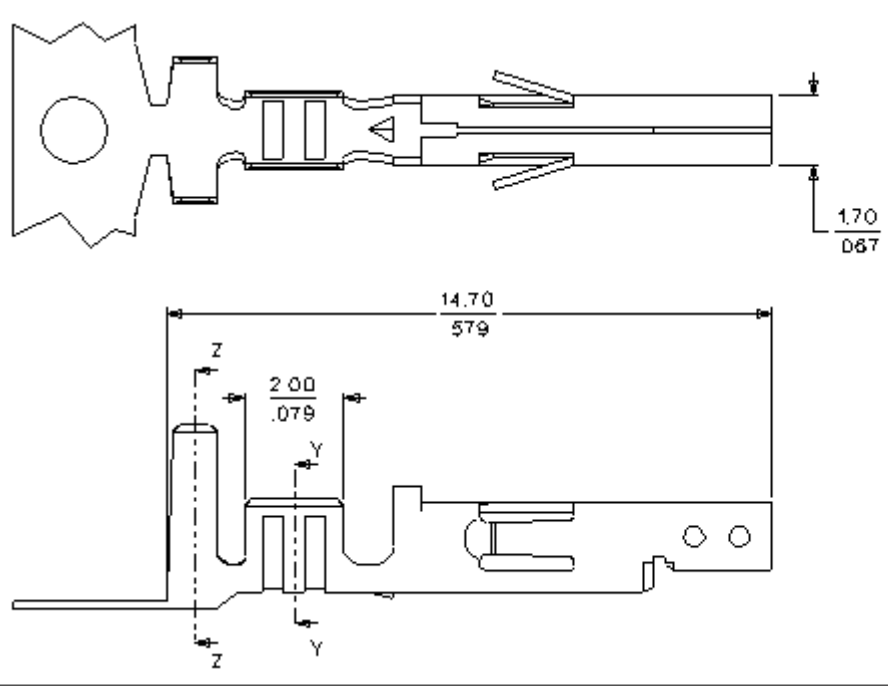

© Copyright 2005 Molex Incorporated
2.09 secs