

REF -50 OPTION SCREW
(WHERE APPLICABLE)

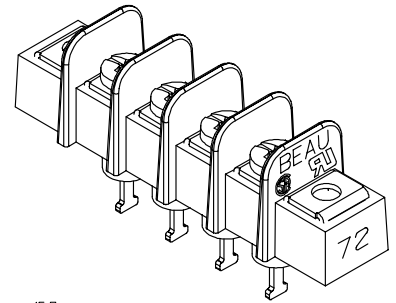

4 CIRCUIT SHOWN

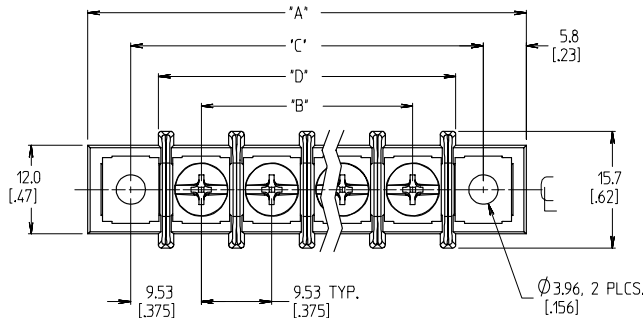
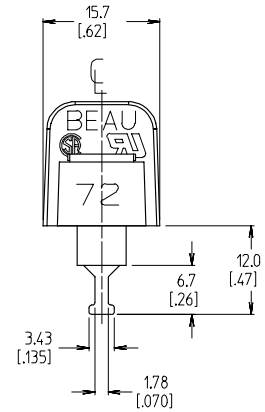
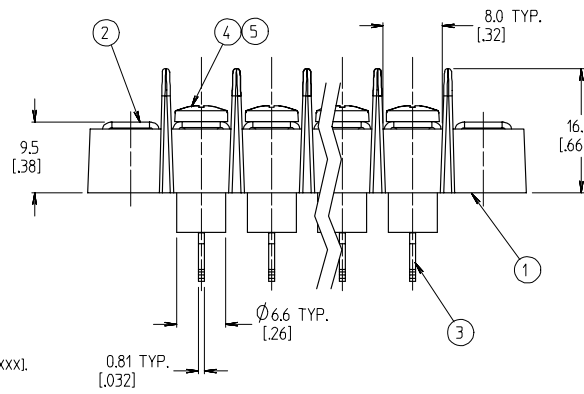

- NOTES:
1. MATERIAL: SEE TABLE
 2. INCH DIMENSIONS ARE SHOWN IN BRACKETS [XXX].
 3. 'XX' REFERS TO THE QUANTITY OF CIRCUITS.
 4. ALL COMPONENTS ARE ROHS COMPLIANT.

ITEM	QTY	DESCRIPTION	MATERIAL	FINISH
6	XX	SCREW&WASHER, 6-32X.250, PAN, PH/SL (-50 OPTION)	STEEL	ZN, CLEAR CHROMATE
5	XX	SCREW, 6-32X.250, BHD, PHIL-SLOT (-49 OPTION)	BRASS	NICKEL
4	XX	SCREW, 6-32X.250, BHD, PHIL-SLOT (STANDARD)	STEEL	ZN, CLEAR CHROMATE
3	XX	TERMINAL, SOLDER TURRET	BRASS	TIN
2	XX	MOUNTING PLATE	BRASS	NICKEL
1	1	INSULATOR, SR, W/MTG	THERMOPLASTIC	BLACK

INITIAL RELEASE	QUALITY SYMBOLS	GENERAL TOLERANCES (UNLESS SPECIFIED)	DIMENSION STYLE	SCALE	DESIGN UNITS	THIRD ANGLE PROJECTION
EC NO: ETC2007-0073	▽=0	mm INCH	MM/IN	2:1	INCH	☉
2006/09/28	▽=0	4 PLACES ± --- ± ---	DRAWN BY	DATE	TITLE	
DRW:EHILLE		3 PLACES ± --- ± .005	EHILE	2006/09/13	9.53MM [0.375] SR BTS	
CHKD:JMACNEIL		2 PLACES ± 0.13 ± .01	CHECKED BY	DATE	ASSY, INSULATED TURRET	
APPR:JMACNEIL		1 PLACE ± 0.25 ± ---	JMACNEIL	2006/09/13	TERMINAL W/MTG	
		ANGULAR ± 2 °	APPROVED BY	DATE	MOLEX INCORPORATED	
		DRAFT WHERE APPLICABLE MUST REMAIN WITHIN DIMENSIONS	JMACNEIL	2006/09/13	MOLEX INCORPORATED	
			MATERIAL NO.	DOCUMENT NO.	SD-38720-010	STEEL NO.
			SEE CHART			1 OF 2
			SIZE B	THIS DRAWING CONTAINS INFORMATION THAT IS PROPRIETARY TO MOLEX INCORPORATED AND SHOULD NOT BE USED WITHOUT WRITTEN PERMISSION		

NO. OF CIRCUITS	DIM. "A"		DIM. "B"		DIM. "C"		DIM. "D"		ASSEMBLY MATERIAL NO. (STANDARD)	ASSEMBLY MATERIAL NO. (-49 OPT)	ASSEMBLY MATERIAL NO. (-50 OPT)
	mm	in	mm	in	mm	in	mm	in			
02	40.1	1.58	9.53	0.375	28.58	1.125	21.1	0.83	387203202	387203502	387203802
03	49.7	1.96	19.05	0.750	38.10	1.500	30.7	1.21	387203203	387203503	387203803
04	59.2	2.33	28.58	1.125	47.63	1.875	40.2	1.58	387203204	387203504	387203804
05	68.7	2.71	38.10	1.500	57.15	2.250	49.7	1.96	387203205	387203505	387203805
06	78.2	3.08	47.63	1.875	66.68	2.625	59.2	2.33	387203206	387203506	387203806
07	87.8	3.46	57.15	2.250	76.20	3.000	68.8	2.71	387203207	387203507	387203807
08	97.3	3.83	66.68	2.625	85.73	3.375	78.3	3.08	387203208	387203508	387203808
09	106.8	4.21	76.20	3.000	95.25	3.750	87.8	3.46	387203209	387203509	387203809
10	116.3	4.58	85.73	3.375	104.78	4.125	97.3	3.83	387203210	387203510	387203810
11	125.9	4.96	95.25	3.750	114.30	4.500	106.9	4.21	387203211	387203511	387203811
12	135.4	5.33	104.78	4.125	123.83	4.875	116.4	4.58	387203212	387203512	387203812
13	144.9	5.71	114.30	4.500	133.35	5.250	125.9	4.96	387203213	387203513	387203813
14	154.4	6.08	123.83	4.875	142.88	5.625	135.4	5.33	387203214	387203514	387203814
15	164.0	6.46	133.35	5.250	152.40	6.000	145.0	5.71	387203215	387203515	387203815
16	173.5	6.83	142.88	5.625	161.93	6.375	154.5	6.08	387203216	387203516	387203816
17	183.0	7.21	152.40	6.000	171.45	6.750	164.0	6.46	387203217	387203517	387203817
18	192.5	7.58	161.93	6.375	180.98	7.125	173.5	6.83	387203218	387203518	387203818
19	202.1	7.96	171.45	6.750	190.50	7.500	183.1	7.21	387203219	387203519	387203819
20	211.6	8.33	180.98	7.125	200.03	7.875	192.6	7.58	387203220	387203520	387203820
21	221.1	8.71	190.50	7.500	209.55	8.250	202.1	7.96	387203221	387203521	387203821
22	230.6	9.08	200.03	7.875	219.08	8.625	211.6	8.33	387203222	387203522	387203822
23	240.2	9.46	209.55	8.250	228.60	9.000	221.2	8.71	387203223	387203523	387203823
24	249.7	9.83	219.08	8.625	238.13	9.375	230.7	9.08	387203224	387203524	387203824
25	259.2	10.21	228.60	9.000	247.65	9.750	240.2	9.46	387203225	387203525	387203825
26	268.7	10.58	238.13	9.375	257.18	10.125	249.7	9.83	387203226	387203526	387203826

INITIAL RELEASE EC NO: ETC2007-0073 DRAWN BY: EHILE 2006/09/13 CHECKED: JMACNEIL 2006/09/13 APPR: JMACNEIL 2006/09/13 A	QUALITY SYMBOLS ▽=0 ▽=0	GENERAL TOLERANCES (UNLESS SPECIFIED)		DIMENSION STYLE MM/IN		SCALE 2:1	DESIGN UNITS INCH	THIRD ANGLE PROJECTION	
		4 PLACES ± --- ± ---	3 PLACES ± --- ± .005	DRAWN BY EHILE	DATE 2006/09/13	9.53MM [.375] SR BTS ASSY, INSULATED TURRET TERMINAL W/MTG			
		2 PLACES ± 0.13 ± .01	1 PLACE ± 0.25 ± ---	CHECKED BY JMACNEIL	DATE 2006/09/13				
		ANGULAR ± 2 °		APPROVED BY JMACNEIL	DATE 2006/09/13	MOLEX INCORPORATED			
DRAFT WHERE APPLICABLE MUST REMAIN WITHIN DIMENSIONS		MATERIAL NO. SEE CHART	DOCUMENT NO. SD-38720-010	STEEL NO. 2 OF 2					

Beau® Barrier Strips

Beau terminal blocks provide a robust connection between wires and the PCB.

Beau terminal blocks are a great connector for their durability and versatility. Barrier strips can handle currents of up to 45.0A per circuit and all are rated for 300 or 600V. With the variety of terminal styles, screws and other options available on barrier strips, these parts can be customized in many ways.

Special additions to barrier strips such as topside hardware, marker strips and hinged covers ensure that you get the best possible connector designed specifically for your application.

Features

- Optional topside hardware allows for further customization to fit your design requirements
- Robust and durable screw terminals are ultrasonically welded into the thermoplastic insulator, reducing the risk for terminal twisting and solder joint failure
- Tri-barrier construction of some barrier strips provides a back wall to prevent over insertion and shorting
- No special tools required to terminate wires, only a No. 2 screwdriver required
- Broad range of screw and terminal options improves interconnect performance
- Various imprinting styles aid in labeling circuits for wiring, testing and repair in the field
- UL recognized and CSA approved
- RoHS and ELV compliant

Barrier Terminal Strips



Features and Benefits

- Robust and durable welded construction
- Wide variety of screw and terminal options
- Molded to exact length, no unsightly saw cuts

Reference Information

UL File No.: E48521
UL Guide No.: XCFR2
CSA File No.: 025562

Screw Only	Insulated Solder	Insulated PC	Centerline PC	Solder Turret	Centerline Wire Wrap	Centerline Right Angle PC	Insulated Fast On	Offset PC	Offset Wire Wrap	Offset Right Angle PC
All	38710 38720 38730	38710 38720 38730	38630 38710 38720 38730 38740	38630/38631 38710/38711 38720/38721 38730/38731	38631 38711 38721 38731	38711 38721 38731 38741	38711 38721 38731 38741	38700 38610	38701	38701

Circuits	Series	Pitch	Current	Voltage	Wire Range AWG	Lead-free
2-16	38630/38631	11.12 (.438)	25.0A	600V	12-24	Yes
2-30	38700/38701	8.25 (.325)	20.0A	300V	12-22	
2-26	38710/38711	9.52 (.375)	25.0A		12-24	
	38720/38721				10-24	
2-30	38730/38731/38732	11.12 (.438)	30.0A	300V		
	38740/38741/38742					
2-32	38610	6.35 (.250)	10.0A	300V		