

MECHANICAL:

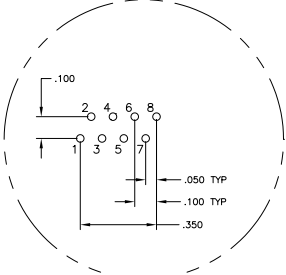

Pin Designations

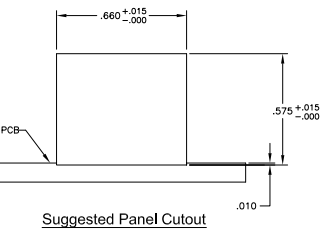
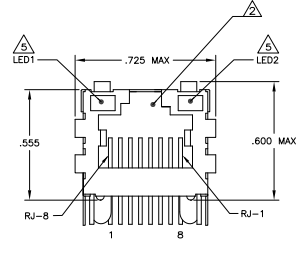
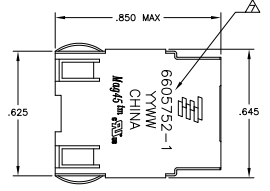
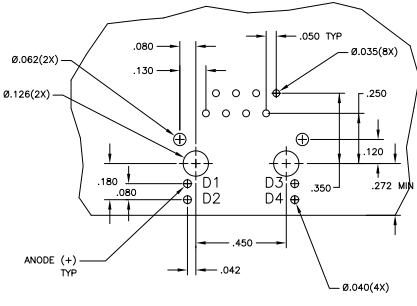
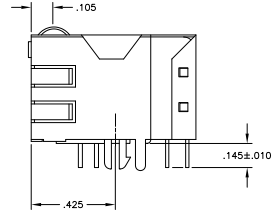

Suggested PCB Layout (Component Side)

724 SERIES MAGNETIC CIRCUIT

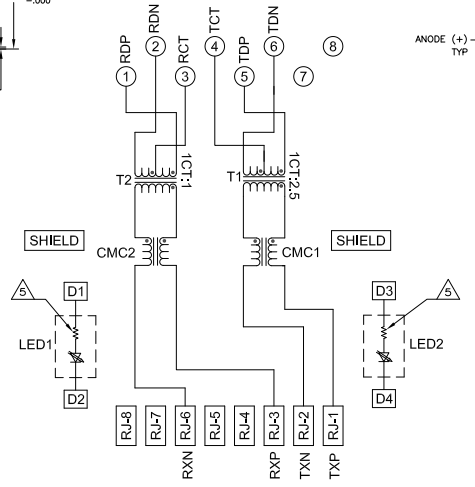

- MATERIALS:**
- HOUSING - THERMOPLASTIC PET POLYESTER FLAMMABILITY RATING UL 94V-0
 - SHIELD - .010" THICK, C28800 BRASS PREPLATED WITH 30μINCH MIN SEMI-BRIGHT NICKEL. SOLDER TABS POST DIPPED WITH 100μINCH MIN SAC SOLDER.
 - MOD JACK CONTACTS - 0.0157" x 0.018" PHOSPHOR BRONZE, 50μINCH MIN OVERALL NICKEL UNDERPLATE, WITH SELECT 50μINCH MIN HARD GOLD FINISH PLATE.
 - SOLDER TAILS WITH 100μINCH MIN MATTE TIN AND/OR SAC SOLDER DIP.
 - LIGHT EMITTING DIODE(LED) - DIFFUSED EPOXY LENS, .020" x .020" CARBON STEEL WIREFRAME LEADS PRE-PLATED WITH 80μINCH SILVER OVER 40μINCH NICKEL UNDERPLATE OVER 40μINCH COPPER UNDERPLATE, POST-PLATED WITH 100μINCH MIN MATTE TIN AND/OR SAC SOLDER DIP OR PURE TIN SOLDER DIP.
- RJ45 JACK CAVITY CONFORMS TO FCC RULES AND REGULATIONS PART 68, SUB PART F.**
- MAGNETICS**
- APPLICATION: 10 BASE-T
 - IMPEDANCE: 100 OHMS
 - TURNS RATIO (CHIP-CABLE): TX = 1.25 RX = 1.1
 - TRANSMIT OPEN CIRCUIT INDUCTANCE (OCL): 14.0mH MIN @ 100kHz, 0.1VRMS
 - LEAKAGE INDUCTANCE (LL): 0.30mH MAX @ 100kHz, 0.1VRMS
 - INTERWINDING CAPACITANCE (CWI): 15pF MAX @ 100kHz, 0.1VRMS
 - ISOLATION VOLTAGE: COMPLIES WITH IEEE802.3 2002, PARA 15.3.4, ITEM a.

- 4. OPERATING TEMPERATURE: FROM 0 °C TO +70 °C.**
- △ THE 250 OHM LED RESISTORS ARE OPTIONAL, PLEASE SEE CHART FOR PRESENCE OR ABSENCE OF LED RESISTORS. IF THE LED WITHOUT 250 OHM RESISTORS, LED IS DRIVEN WITH CONSTANT CURRENT AT APPROX 20mA. LED COLOR:**
 DOMINANT WAVELENGTH (λD): GREEN 568 nm TYP. @ IF=20mA
 FORWARD VOLTAGE (VF) GREEN 2.2V TYP. @ IF=20mA
 DOMINANT WAVELENGTH (λD): YELLOW 588 nm TYP. @ IF=20mA
 FORWARD VOLTAGE (VF) YELLOW 2.1V TYP. @ IF=20mA
IF THE LED WITH 250 OHM RESISTORS, LED IS DRIVEN WITH 5V VOLTAGE AND THE MAX OPERATING CURRENT IS 20mA. LED COLOR:
 DOMINANT WAVELENGTH (λD): GREEN 568 nm TYP. @ VF=5V
 FORWARD CURRENT (IF) GREEN 12 mA TYP. @ VF=5V
 DOMINANT WAVELENGTH (λD): YELLOW 588 nm TYP. @ VF=5V
 FORWARD CURRENT (IF) YELLOW 13 mA TYP. @ VF=5V
- △ INDICATED CONNECTIONS ARE FOR NIC CONFIGURATION**
- △ TYCO ELECTRONICS, PART NUMBER, DATE CODE, COUNTRY OF ORIGIN AND AGENCY APPROVAL MARKING IN APPROXIMATE LOCATION SHOWN.**
- B. THESE PARTS ARE RECOMMENDED FOR WAVE SOLDERING PROCESS. PREHEAT TEMPERATURE IS 120 °C TO 160 °C, 120 SECONDS TO 180 SECONDS. PEAK WAVE SOLDERING TEMPERATURE IS 260 °C MAX, 10 SECONDS MAX.**

YES	GREEN	YES	GREEN	1-6605752-1
NO	GREEN	NO	GREEN	6605752-7
YES	GREEN	YES	YELLOW	6605752-1
LED RESISTOR	LED1	LED RESISTOR	LED2	PART NUMBER

THIS DRAWING IS A CONTROLLED DOCUMENT. STMicroelectronics

INFORMATION: 1X1 MAC45(TM), MODULAR JACK, 7N3 10BASE-T ETHERNET SCHEMATIC, 724 SERIES MAGNETIC CIRCUIT, SHIELDED, WITH LEDS

DATE: 108-2100

DATE SIZE: 108-2100

CUSTOMER DRAWING: A100779 (G) 6605752