

REV	DATE	DESCRIPTION	BY	CHK	APP
J2		REVISED PER ECO-11-005140			

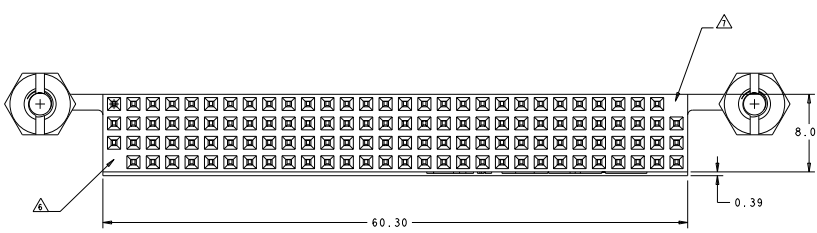

- △ HOUSING: HIGH TEMPERATURE, GLASS FILLED NYLON, COLOR: BLACK.
CONTACTS: PHOSPHOR BRONZE.
SCREWLOCKS: STEEL.
- △ CONTACTS: 0.000381 MIN GOLD ON MATING RECEPTACLE END, 0.000130 MIN GOLD ON REMAINDER, ALL OVER 0.001270 NICKEL.
SCREWLOCKS: CLEAR CHROMATE OVER ZINC.
- △ PCB HOLE RECOMMENDATIONS:
A. DRILL HOLE DIAMETER TO BE 1.00±0.02.
B. PLATING TO BE 0.005 MIN TIN-LEAD OVER 0.025-0.075 COPPER.
C. RECOMMENDED FINISH HOLE SIZE IS 0.88±0.08.
- △ DIMENSION AFTER SEATING TO PCB.
- △ POSITION TOLERANCE APPLIES AFTER CONNECTOR IS PRESSED ONTO PC BOARD.
- △ NO CONTACT IN THIS POSITION FOR PART NUMBER 1375797-2 ONLY.
- △ NO CONTACT IN THIS POSITION FOR PART NUMBER 1375797-3 ONLY.
- △ CONTACTS: 0.000381 MIN GOLD ON MATING RECEPTACLE END, 0.00254-0.00508 MATTE TIN ON COMPLIANT AREA, 0.000130 MIN GOLD OVER REMAINDER, ALL OVER 0.001270 NICKEL.
SCREWLOCKS: CLEAR CHROMATE OVER ZINC.
- △ TO BE USED ON SILVER IMMERSION PLATED PCB'S (NOTE 10).
- △ PCB HOLE RECOMMENDATIONS FOR SILVER IMMERSION PLATING:
A. DRILL HOLE DIAMETER TO BE 1.04±0.02.
B. PLATING TO BE 0.0001524-0.0004064 SILVER OVER 0.0508±0.0254 COPPER.
C. RECOMMENDED FINISH HOLE SIZE IS 0.94-1.03.
- △ PCB HOLE RECOMMENDATIONS FOR ENIG PLATING:
A. DRILL HOLE DIAMETER TO BE 1.04±0.02.
B. PLATING TO BE 0.000051-0.000127 GOLD OVER 0.00305-0.00610 NICKEL ALL OVER 0.0508±0.0254 COPPER.
C. RECOMMENDED FINISH HOLE SIZE IS 0.94-1.03.
- △ TO BE USED ON STANDARD PCB (NOTE 3) OR ENIG PLATED PCB (NOTE 11).
- △ OBSOLETE PARTS: OBSOLETE CIS STREAMLINING PER D.RENAUD/D.SINISI

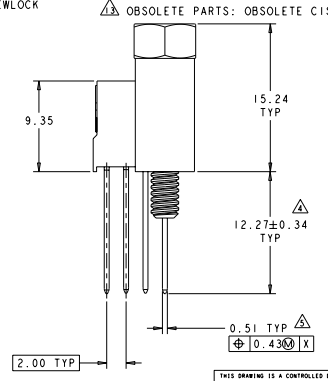
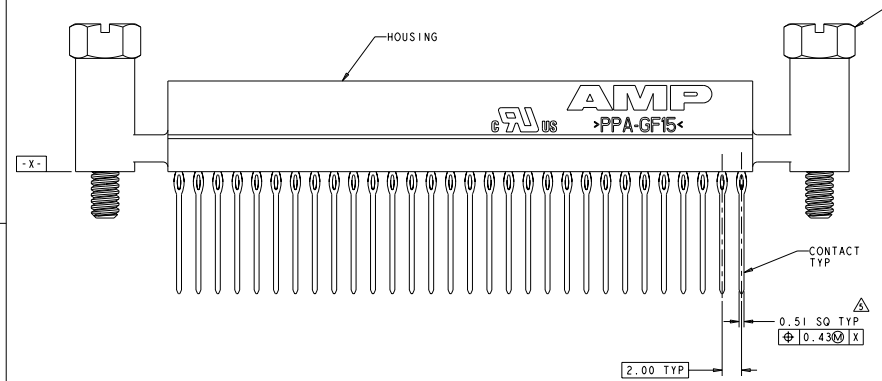

△	△	YES	△	1375797-6	△
△	△	YES	△	1375797-5	△
△	△	NO	△	1375797-4	△
△	△	YES	△	1375797-3	△
△	△	YES	△	1375797-2	△
△	△	NO	△	1375797-1	△
FINISH KEYED CIRCUITS				PART NO	

THIS DRAWING IS A CONTROLLED DOCUMENT.

DATE: 13JUN2007
 RELEASED BY: 13JUN2007
 DRAWN BY: 108-1856
 CHECKED BY: 116-13821
 APPROVED BY: 100779

ASSEMBLY: PC/104-PLUS, STACKTHROUGH CONTACTS, 2 STANDOFFS, PRESS FIT

STATE CASE CODE (DRAWING NO): A | 00779 | 1375797

CUSTOMER DRAWING

