



PN2222A

## SMALL SIGNAL NPN TRANSISTOR

PRELIMINARY DATA

Ordering Code	Marking	Package / Shipment
PN2222A	PN2222A	TO-92 / Bulk
PN2222A-AP	PN2222A	TO-92 / Ammopack

- SILICON EPITAXIAL PLANAR NPN TRANSISTOR
- TO-92 PACKAGE SUITABLE FOR THROUGH-HOLE PCB ASSEMBLY
- THE PNP COMPLEMENTARY TYPE IS PN2907A

### APPLICATIONS

- WELL SUITABLE FOR TV AND HOME APPLIANCE EQUIPMENT
- SMALL LOAD SWITCH TRANSISTOR WITH HIGH GAIN AND LOW SATURATION VOLTAGE

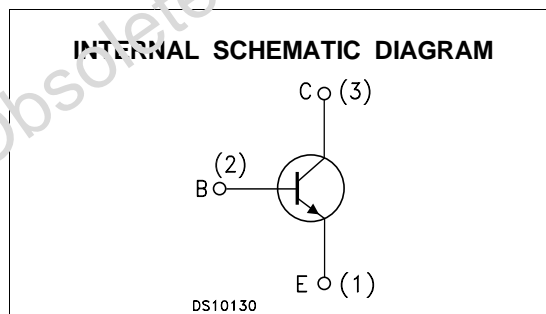
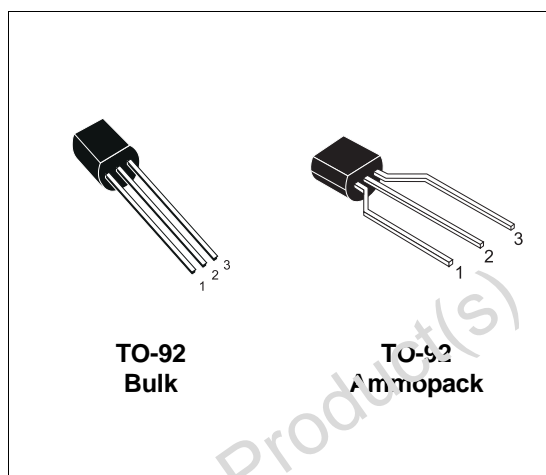

### ABSOLUTE MAXIMUM RATINGS

Symbol	Parameter	Value	Unit
$V_{CBO}$	Collector-Emitter Voltage ( $I_E = 0$ )	75	V
$V_{CEO}$	Collector-Emitter Voltage ( $I_B = 0$ )	40	V
$V_{EBO}$	Emitter-Base Voltage ( $I_C = 0$ )	6	V
$I_C$	Collector Current	0.6	A
$I_{CM}$	Collector Peak Current ( $t_p < 5$ ms)	0.8	A
$P_{tot}$	Total Dissipation at $T_{amb} = 25$ °C	500	mW
$T_{stg}$	Storage Temperature	-65 to 150	°C
$T_j$	Max. Operating Junction Temperature	150	°C

**THERMAL DATA**

R <sub>thj-amb</sub> •	Thermal Resistance Junction-Ambient	Max	250	°C/W
R <sub>thj-case</sub> •	Thermal Resistance Junction-Case	Max	83.3	°C/W

**ELECTRICAL CHARACTERISTICS** (T<sub>case</sub> = 25 °C unless otherwise specified)

Symbol	Parameter	Test Conditions	Min.	Typ.	Max.	Unit
I <sub>CEX</sub>	Collector Cut-off Current (V <sub>BE</sub> = -3 V)	V <sub>CE</sub> = 60 V			10	nA
I <sub>BEX</sub>	Base Cut-off Current (V <sub>BE</sub> = -3 V)	V <sub>CE</sub> = 60 V			20	nA
I <sub>CBO</sub>	Collector Cut-off Current (I <sub>E</sub> = 0)	V <sub>CB</sub> = 75 V V <sub>CB</sub> = 75 V T <sub>j</sub> = 150 °C			10 10	nA μA
I <sub>EBO</sub>	Emitter Cut-off Current (I <sub>C</sub> = 0)	V <sub>EB</sub> = 3 V			15	nA
V <sub>(BR)CEO</sub> *	Collector-Emitter Breakdown Voltage (I <sub>B</sub> = 0)	I <sub>C</sub> = 10 mA	40			V
V <sub>(BR)CBO</sub>	Collector-Base Breakdown Voltage (I <sub>E</sub> = 0)	I <sub>C</sub> = 10 μA	75			V
V <sub>(BR)EBO</sub>	Emitter-Base Breakdown Voltage (I <sub>C</sub> = 0)	I <sub>E</sub> = 10 μA	6			V
V <sub>CE(sat)</sub> *	Collector-Emitter Saturation Voltage	I <sub>C</sub> = 150 mA I <sub>B</sub> = 15 mA I <sub>C</sub> = 500 mA I <sub>B</sub> = 50 mA			0.3 1	V V
V <sub>BE(sat)</sub> *	Collector-Base Saturation Voltage	I <sub>C</sub> = 150 mA I <sub>B</sub> = 15 mA I <sub>C</sub> = 500 mA I <sub>B</sub> = 50 mA	0.6		1.2 2	V V
h <sub>FE</sub> *	DC Current Gain	I <sub>C</sub> = 0.1 mA V <sub>CE</sub> = 10 V I <sub>C</sub> = 1 mA V <sub>CE</sub> = 10 V I <sub>C</sub> = 10 mA V <sub>CE</sub> = 10 V I <sub>C</sub> = 150 mA V <sub>CE</sub> = 10 V I <sub>C</sub> = 150 mA V <sub>CE</sub> = 1 V I <sub>C</sub> = 500 mA V <sub>CE</sub> = 10 V	35 50 75 100 50 40		300	
f <sub>T</sub>	Transition Frequency	I <sub>C</sub> = 20 mA V <sub>CE</sub> = 20V f = 100MHz		270		MHz
C <sub>CBO</sub>	Collector-Base Capacitance	I <sub>E</sub> = 0 V <sub>CB</sub> = 10 V f = 1 MHz		4	8	pF
C <sub>EBO</sub>	Emitter-Base Capacitance	I <sub>C</sub> = 0 V <sub>EB</sub> = 0.5 V f = 1MHz		20	25	pF
NF	Noise Figure	I <sub>C</sub> = 0.1 mA V <sub>CE</sub> = 10 V f = 1 KHz Δf = 200 Hz R <sub>G</sub> = 1 KΩ		4		dB
h <sub>ie</sub> *	Input Impedance	V <sub>CE</sub> = 10 V I <sub>C</sub> = 1 mA f = 1 KHz V <sub>CE</sub> = 10 V I <sub>C</sub> = 10 mA f = 1 KHz	2 0.25		8 1.25	KΩ KΩ
h <sub>re</sub> *	Reverse Voltage Ratio	V <sub>CE</sub> = 10 V I <sub>C</sub> = 1 mA f = 1 KHz V <sub>CE</sub> = 10 V I <sub>C</sub> = 10 mA f = 1 KHz			8 4	10 <sup>-4</sup> 10 <sup>-4</sup>
h <sub>fe</sub> *	Small Signal Current Gain	V <sub>CE</sub> = 10 V I <sub>C</sub> = 1 mA f = 1 KHz V <sub>CE</sub> = 10 V I <sub>C</sub> = 10 mA f = 1 KHz	50 75		300 375	
h <sub>oe</sub> *	Output Admittance	V <sub>CE</sub> = 10 V I <sub>C</sub> = 1 mA f = 1 KHz V <sub>CE</sub> = 10 V I <sub>C</sub> = 10 mA f = 1 KHz	5 25		35 200	μS μS

\* Pulsed: Pulse duration = 300 μs, duty cycle ≤ 2 %

**ELECTRICAL CHARACTERISTICS** (Continued)

Symbol	Parameter	Test Conditions	Min.	Typ.	Max.	Unit
$t_d$	Delay Time	$I_C = 150 \text{ mA}$ $I_B = 15 \text{ mA}$ $V_{CC} = 30 \text{ V}$		5	10	ns
$t_r$	Rise Time			12	25	ns
$t_s$	Storage Time	$I_C = 150 \text{ mA}$ $I_{B1} = - I_{B2} = 15 \text{ mA}$ $V_{CC} = 30 \text{ V}$		185	225	ns
$t_f$	Fall Time			24	60	ns

\* Pulsed: Pulse duration = 300  $\mu\text{s}$ , duty cycle  $\leq 2\%$

Obsolete Product(s) - Obsolete Product(s)

**TO-92 MECHANICAL DATA**

DIM.	mm			inch		
	MIN.	TYP.	MAX.	MIN.	TYP.	MAX.
A	4.32		4.95	0.170		0.195
b	0.36		0.51	0.014		0.020
D	4.45		4.95	0.175		0.194
E	3.30		3.94	0.130		0.155
e	2.41		2.67	0.095		0.105
e1	1.14		1.40	0.045		0.055
L	12.70		15.49	0.500		0.609
R	2.16		2.41	0.085		0.094
S1	1.14		1.52	0.045		0.059
W	0.41		0.56	0.016		0.022
V	4 degree		6 degree	4 degree		6 degree

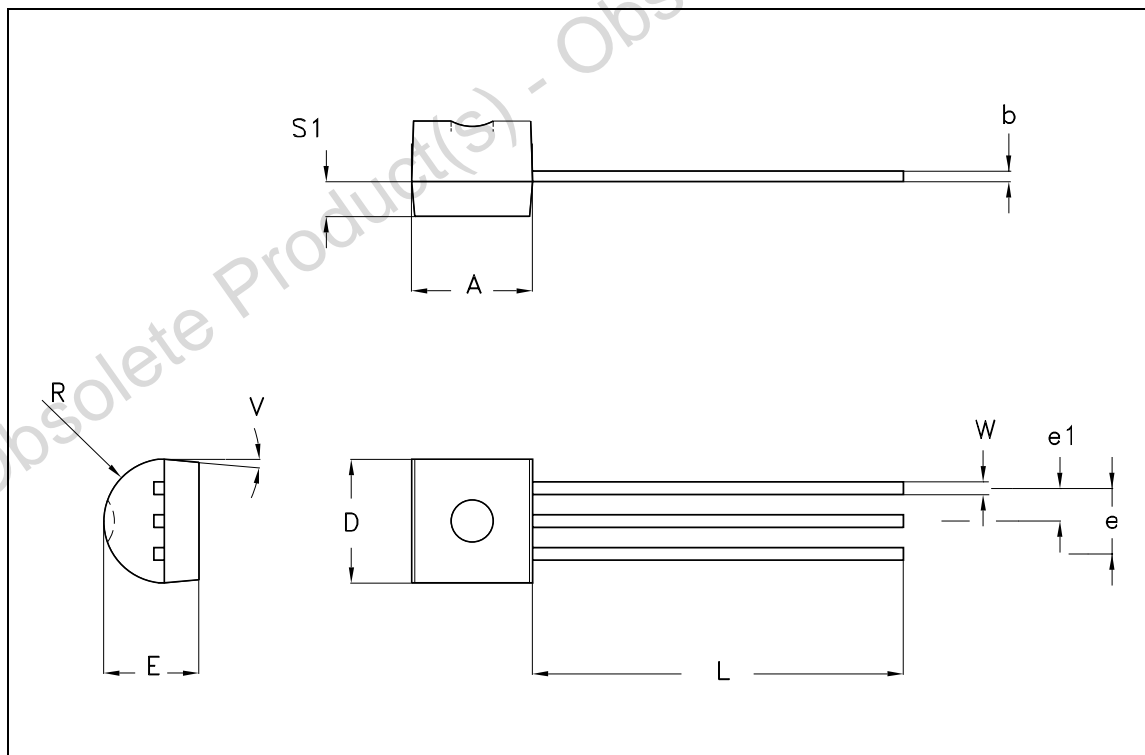

**TO-92 AMMOPACK SHIPMENT (Suffix "-AP") MECHANICAL DATA**

DIM.	mm			inch		
	MIN.	TYP.	MAX.	MIN.	TYP.	MAX.
A1			4.80			0.189
T			3.80			0.150
T1			1.60			0.063
T2			2.30			0.091
d			0.48			0.019
P0	12.50	12.70	12.90	0.492	0.500	0.508
P2	5.65	6.35	7.05	0.222	0.250	0.278
F1,F2	2.44	2.54	2.94	0.096	0.100	0.116
delta H	-2.00		2.00	-0.079		0.079
W	17.50	18.00	19.00	0.689	0.709	0.748
W0	5.70	6.00	6.30	0.224	0.236	0.248
W1	8.50	9.00	9.25	0.335	0.354	0.364
W2			0.50			0.020
H	18.50		20.50	0.728		0.807
H0	15.50	16.00	16.50	0.610	0.630	0.650
H1			25.00			0.984
D0	3.80	4.00	4.20	0.150	0.157	0.165
t			0.90			0.035
L			11.00			0.433
I1	3.00			0.118		
delta P	-1.00		1.00	-0.039		0.039

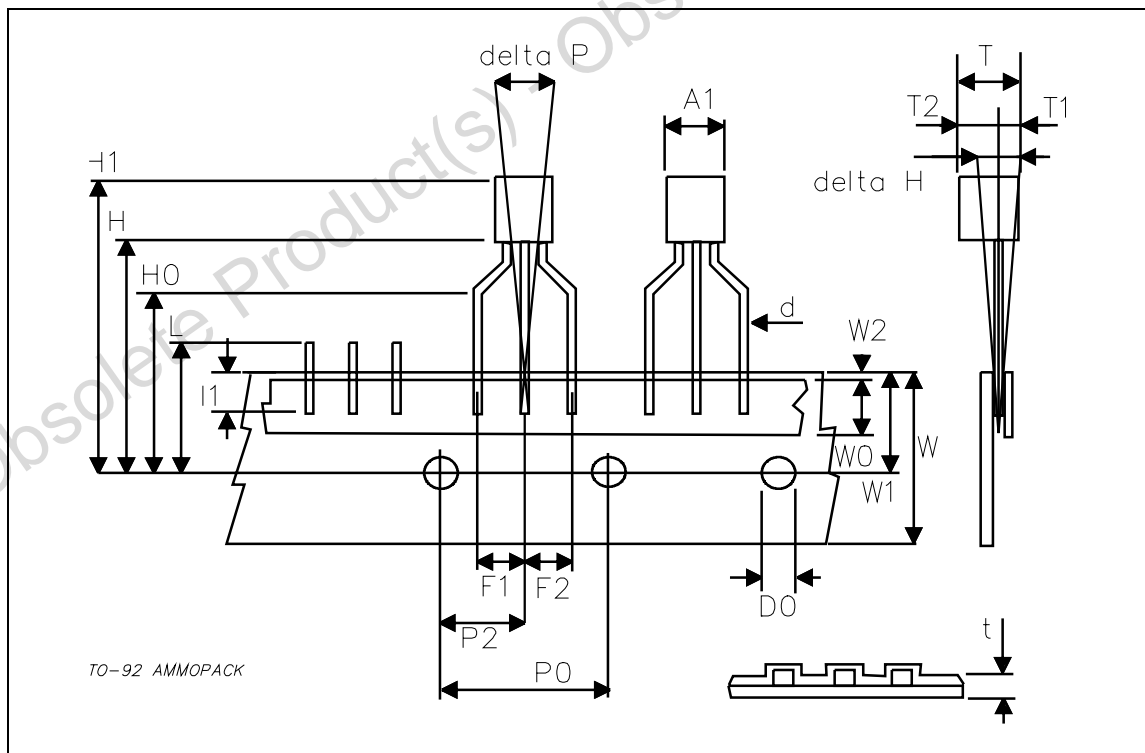

Obsolete Product(s) - Obsolete Product(s)

Information furnished is believed to be accurate and reliable. However, STMicroelectronics assumes no responsibility for the consequences of use of such information nor for any infringement of patents or other rights of third parties which may result from its use. No license is granted by implication or otherwise under any patent or patent rights of STMicroelectronics. Specification mentioned in this publication are subject to change without notice. This publication supersedes and replaces all information previously supplied. STMicroelectronics products are not authorized for use as critical components in life support devices or systems without express written approval of STMicroelectronics.

The ST logo is a trademark of STMicroelectronics

© 2003 STMicroelectronics – Printed in Italy – All Rights Reserved  
STMicroelectronics GROUP OF COMPANIES

Australia - Brazil - Canada - China - Finland - France - Germany - Hong Kong - India - Israel - Italy - Japan - Malaysia - Malta - Morocco - Singapore - Spain - Sweden - Switzerland - United Kingdom - United States.

<http://www.st.com>