

SMALL SIGNAL PNP TRANSISTORS

DESCRIPTION

The 2N2905A and 2N2907A are silicon Planar Epitaxial PNP transistors in Jedec TO-39 (for 2N2905A) and in Jedec TO-18 (for 2N2907A) metal case. They are designed for high speed saturated switching and general purpose applications.

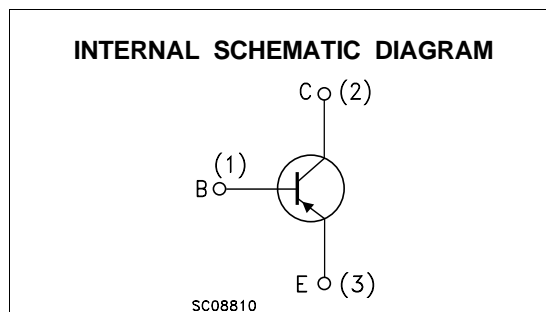
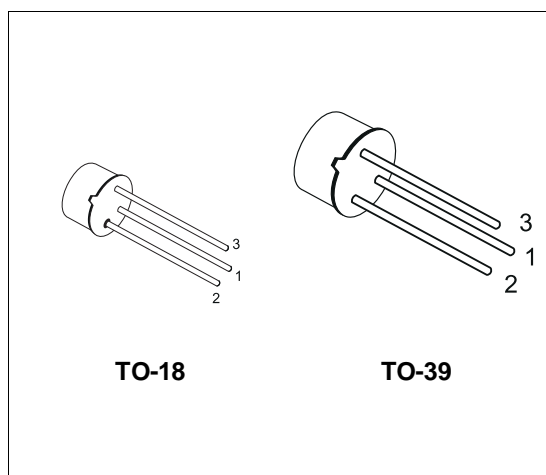

ABSOLUTE MAXIMUM RATINGS

Symbol	Parameter	Value	Unit
V_{CBO}	Collector-Base Voltage ($I_E = 0$)	-60	V
V_{CEO}	Collector-Emitter Voltage ($I_B = 0$)	-60	V
V_{EBO}	Emitter-Base Voltage ($I_C = 0$)	-5	V
I_C	Collector Current	-0.6	A
I_{CM}	Collector Peak Current ($t_p < 5$ ms)	-0.8	A
P_{tot}	Total Dissipation at $T_{amb} \leq 25$ °C for 2N2905A for 2N2907A at $T_C \leq 25$ °C for 2N2905A for 2N2907A	0.6	W
		0.4	W
		3	W
		1.8	W
T_{stg}	Storage Temperature	-65 to 175	°C
T_j	Max. Operating Junction Temperature	175	°C

2N2905A/2N2907A

THERMAL DATA

		TO-39	TO-18	
R _{thj-case}	Thermal Resistance Junction-Case	Max	50	83.3
R _{thj-amb}	Thermal Resistance Junction-Ambient	Max	250	375
				°C/W
				°C/W

ELECTRICAL CHARACTERISTICS (T_{case} = 25 °C unless otherwise specified)

Symbol	Parameter	Test Conditions	Min.	Typ.	Max.	Unit
I _{CBO}	Collector Cut-off Current (I _E = 0)	V _{CB} = -50 V V _{CB} = -50 V T _J = 150 °C			-10 -10	nA μA
I _{CEX}	Collector Cut-off Current (V _{BE} = 0.5V)	V _{CE} = -30 V			-50	nA
I _{BEX}	Base Cut-off Current (V _{BE} = 0.5V)	V _{CE} = -30 V			-50	nA
V _{(BR)CBO}	Collector-Base Breakdown Voltage (I _E = 0)	I _C = -10 μA	-60			V
V _{(BR)CEO*}	Collector-Emitter Breakdown Voltage (I _B = 0)	I _C = -10 mA	-60			V
V _{(BR)EBO}	Emitter-Base Breakdown Voltage (I _C = 0)	I _E = -10 μA	-5			V
V _{CE(sat)*}	Collector-Emitter Saturation Voltage	I _C = -150 mA I _B = -15 mA I _C = -500 mA I _B = -50 mA			-0.4 -1.6	V V
V _{BE(sat)*}	Base-Emitter Saturation Voltage	I _C = -150 mA I _B = -15 mA I _C = -500 mA I _B = -50 mA			-1.3 -2.6	V V
h _{FE*}	DC Current Gain	I _C = -0.1 mA V _{CE} = -10 V I _C = -1 mA V _{CE} = -10 V I _C = -10 mA V _{CE} = -10 V I _C = -150 mA V _{CE} = -10 V I _C = -500 mA V _{CE} = -10 V	75 100 100 100 50		300	
f _T	Transition Frequency	V _{CE} = -20 V f = 100 MHz I _C = -50 mA	200			MHz
C _{EBO}	Emitter-Base Capacitance	I _C = 0 V _{EB} = -2 V f = 1MHz			30	pF
C _{CBO}	Collector-Base Capacitance	I _E = 0 V _{CB} = -10 V f = 1MHz			8	pF
t _{d**}	Delay Time	V _{CC} = -30 V I _C = -150 mA I _{B1} = -15 mA			10	ns
t _{r**}	Rise Time	V _{CC} = -30 V I _C = -150 mA I _{B1} = -15 mA			40	ns
t _{s**}	Storage Time	V _{CC} = -6 V I _C = -150 mA I _{B1} = -I _{B2} = -15 mA			80	ns
t _{f**}	Fall Time	V _{CC} = -6 V I _C = -150 mA I _{B1} = -I _{B2} = -15 mA			30	ns
t _{on**}	Turn-on Time	V _{CC} = -30 V I _C = -150 mA I _{B1} = -15 mA			45	ns
t _{off**}	Turn-off Time	V _{CC} = -6 V I _C = -150 mA I _{B1} = -I _{B2} = -15 mA			100	ns

* Pulsed: Pulse duration = 300 μs, duty cycle ≤ 1 %

** See test circuit

Normalized DC Current Gain.

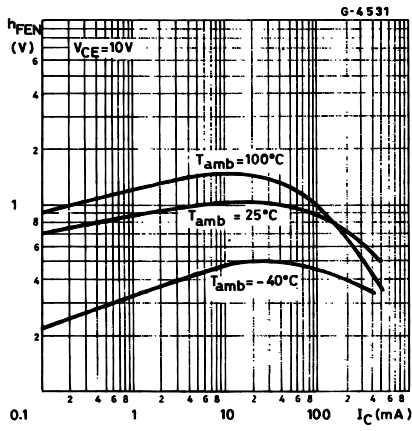

Collector Emitter Saturation Voltage.

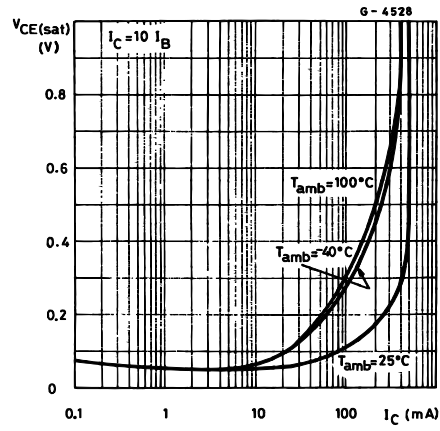

Collector Base and Emitter-base capacitances.

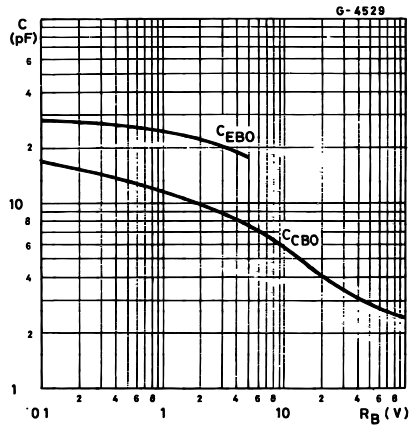

Switching Characteristics.

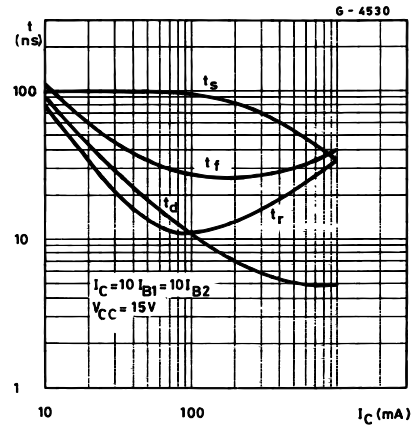

2N2905A/2N2907A

Test Circuit for t_{on} , t_r , t_d .

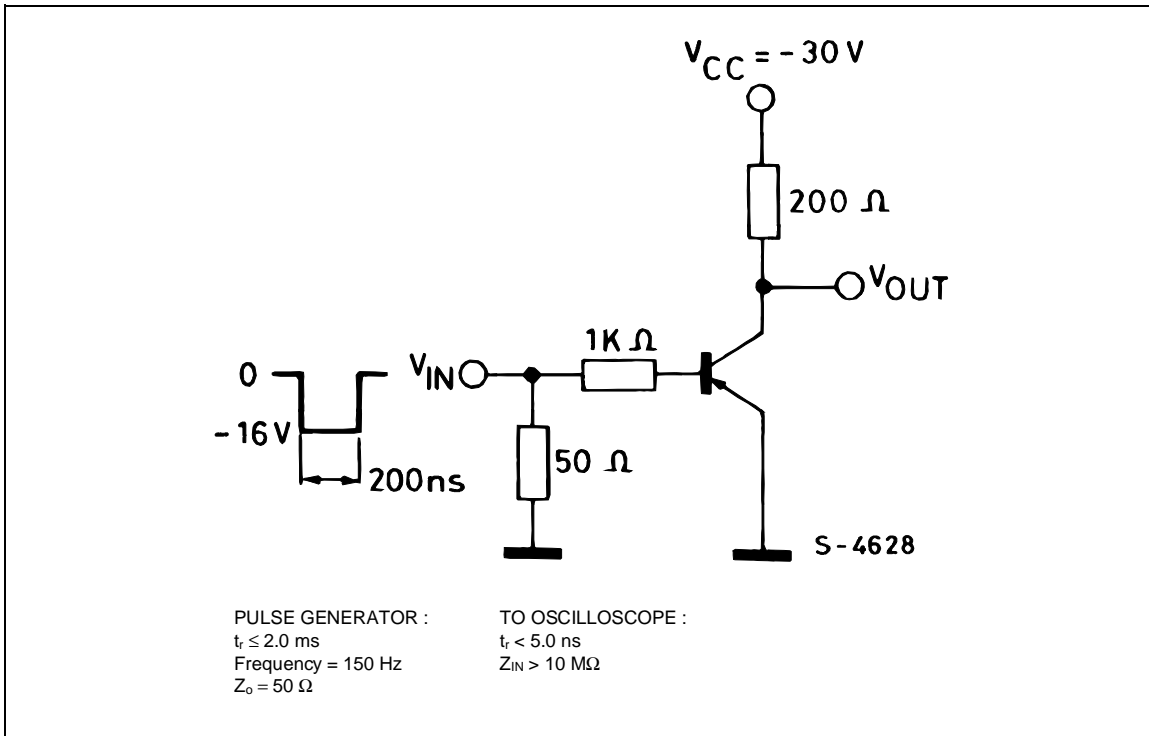

Test Circuit for t_{off} , t_o , t_f .

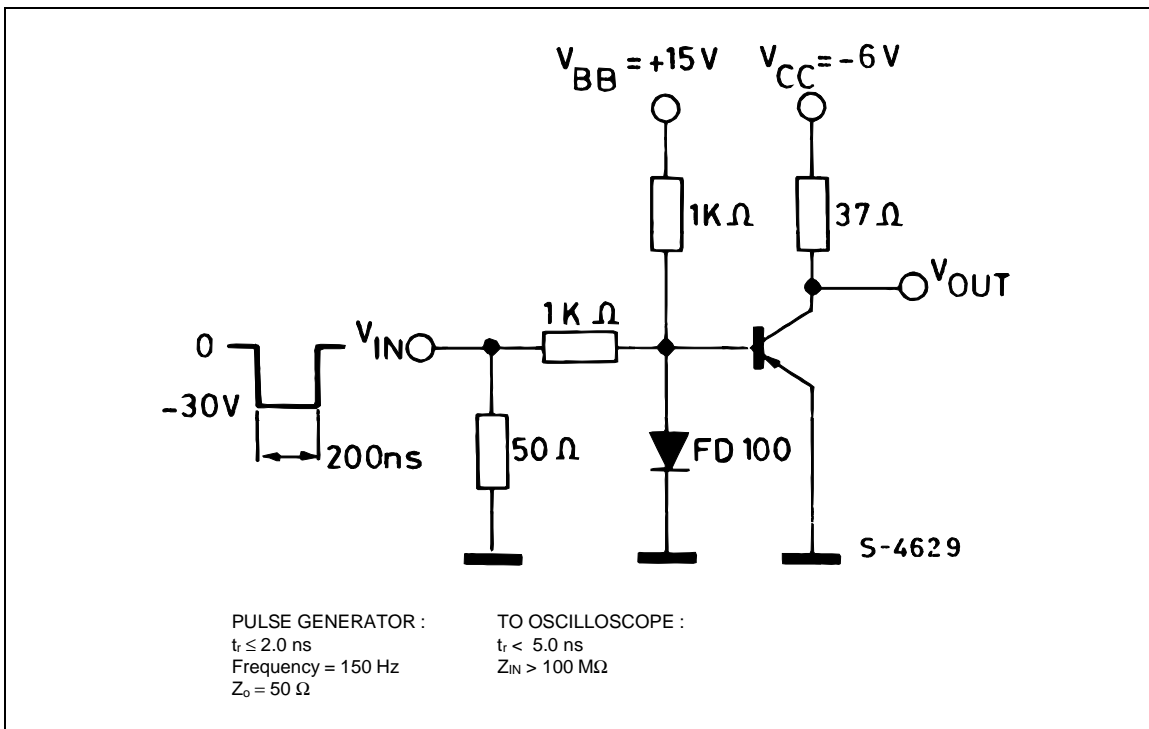

TO-18 MECHANICAL DATA

DIM.	mm			inch		
	MIN.	TYP.	MAX.	MIN.	TYP.	MAX.
A		12.7			0.500	
B			0.49			0.019
D			5.3			0.208
E			4.9			0.193
F			5.8			0.228
G	2.54			0.100		
H			1.2			0.047
I			1.16			0.045
L	45°			45°		

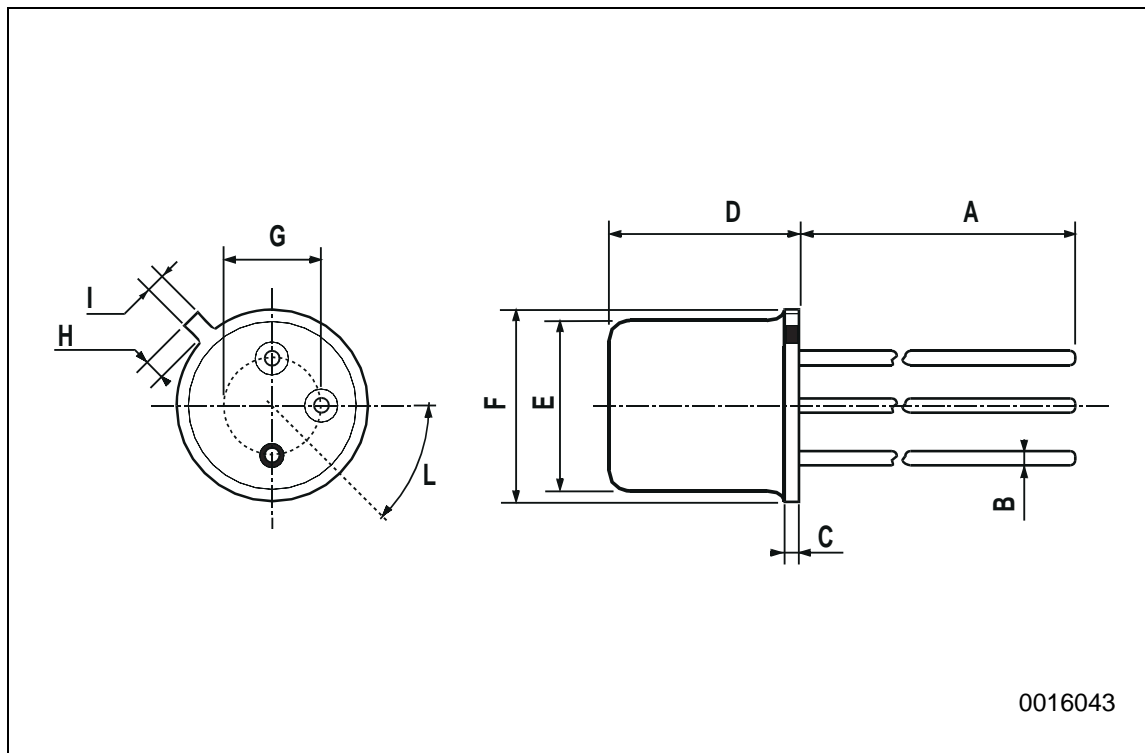

TO-39 MECHANICAL DATA

DIM.	mm			inch		
	MIN.	TYP.	MAX.	MIN.	TYP.	MAX.
A	12.7			0.500		
B			0.49			0.019
D			6.6			0.260
E			8.5			0.334
F			9.4			0.370
G	5.08			0.200		
H			1.2			0.047
I			0.9			0.035
L	45° (typ.)					

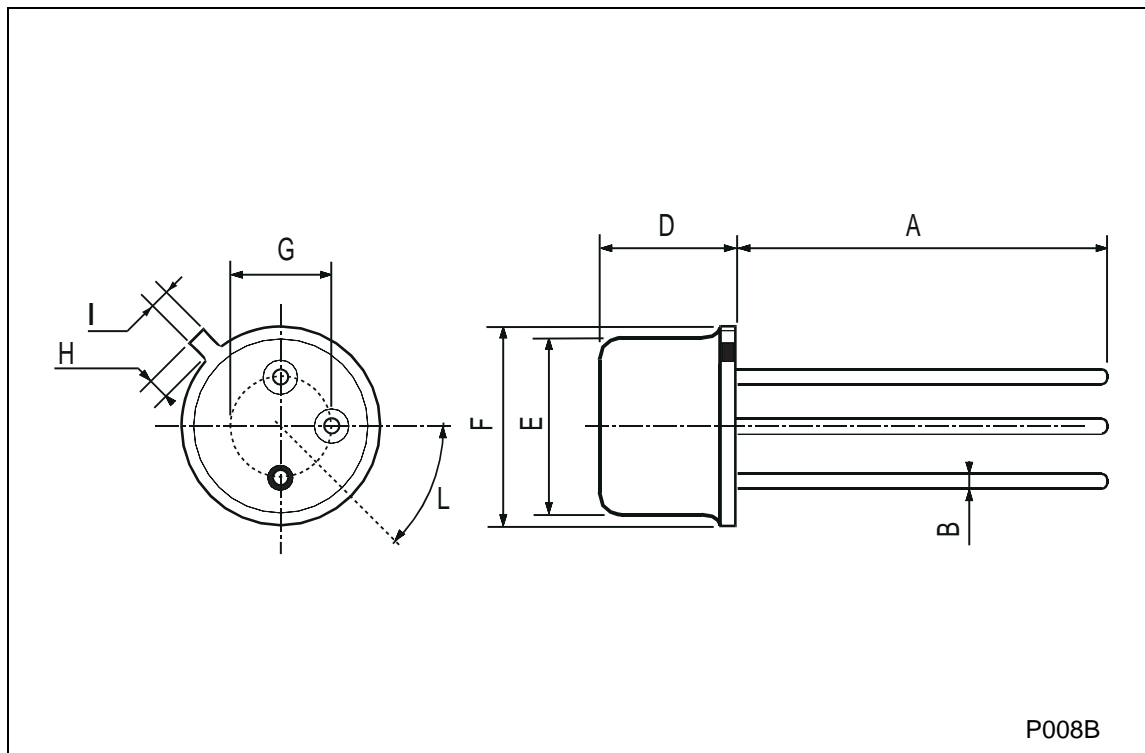

Information furnished is believed to be accurate and reliable. However, STMicroelectronics assumes no responsibility for the consequences of use of such information nor for any infringement of patents or other rights of third parties which may result from its use. No license is granted by implication or otherwise under any patent or patent rights of STMicroelectronics. Specification mentioned in this publication are subject to change without notice. This publication supersedes and replaces all information previously supplied. STMicroelectronics products are not authorized for use as critical components in life support devices or systems without express written approval of STMicroelectronics.

The ST logo is a trademark of STMicroelectronics

© 2003 STMicroelectronics – Printed in Italy – All Rights Reserved
STMicroelectronics GROUP OF COMPANIES

Australia - Brazil - Canada - China - Finland - France - Germany - Hong Kong - India - Israel - Italy - Japan - Malaysia - Malta - Morocco -
Singapore - Spain - Sweden - Switzerland - United Kingdom - United States.

<http://www.st.com>

