



BUL128D-B

HIGH VOLTAGE FAST-SWITCHING NPN POWER TRANSISTOR

- n STMicroelectronics PREFERRED SALES TYPE
- n NPN TRANSISTOR
- n HIGH VOLTAGE CAPABILITY
- n LOW SPREAD OF DYNAMIC PARAMETERS
- n MINIMUM LOT-TO-LOT SPREAD FOR RELIABLE OPERATION
- n VERY HIGH SWITCHING SPEED
- n INTEGRATED ANTIPARALLEL COLLECTOR- EMITTER DIODE

APPLICATIONS

- n ELECTRONIC BALLAST FOR FLUORESCENT LIGHTING
- n FLYBACK AND FORWARD SINGLE TRANSISTOR LOW POWER CONVERTERS

DESCRIPTION

The device is manufactured using high voltage Multi Epitaxial Planar technology for high switching speeds and medium voltage capability. It uses a Cellular Emitter structure with planar edge termination to enhance switching speeds while maintaining the wide RBSOA.

The device is designed for use in lighting applications and low cost switch-mode power supplies.

Figure 1: Package

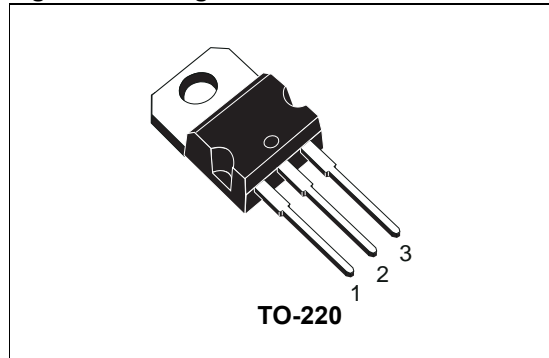

Figure 2: Internal Schematic Diagram

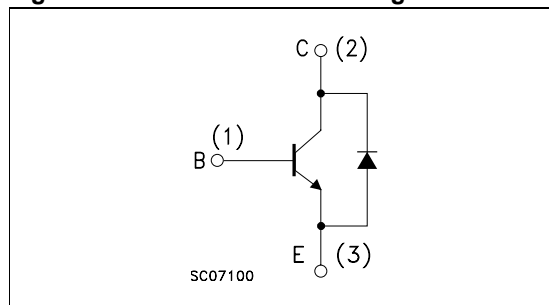

Table 1: Order Codes

Part Number	Marking	Package	Packaging
BUL128D-B	BUL128D-B	TO-220	Tube

Table 2: Absolute Maximum Ratings

Symbol	Parameter	Value	Unit
V_{CES}	Collector-Emitter Voltage ($V_{BE} = 0$)	700	V
V_{CEO}	Collector-Emitter Voltage ($I_B = 0$)	400	V
V_{EBO}	Emitter-Base Voltage ($I_C = 0$, $I_B = 2$ A, $t_p < 10$ μ s, $T_J = 150$ °C)	$V_{(BR)EBO}$	V
I_C	Collector Current	4	A
I_{CM}	Collector Peak Current ($t_p < 5$ ms)	8	A
I_B	Base Current	2	A
I_{BM}	Base Peak Current ($t_p < 5$ ms)	4	A

BUL128D-B

Symbol	Parameter	Value	Unit
P_{tot}	Total Dissipation at $T_C = 25\text{ °C}$	70	W
T_{stg}	Storage Temperature	-65 to 150	°C
T_J	Max. Operating Junction Temperature	150	°C

Table 3: Thermal Data

$R_{thj-case}$	Thermal Resistance Junction-Case	Max	1.78	°C/W
$R_{thj-amb}$	Thermal Resistance Junction-Ambient	Max	62.5	°C/W

Table 4: Electrical Characteristics ($T_{case} = 25\text{ °C}$ unless otherwise specified)

Symbol	Parameter	Test Conditions	Min.	Typ.	Max.	Unit
I_{CES}	Collector Cut-off Current ($V_{BE} = 0\text{ V}$)	$V_{CE} = 700\text{ V}$			100	μA
		$V_{CE} = 700\text{ V}$ $T_J = 125\text{ °C}$			500	μA
I_{CEO}	Collector Cut-off Current ($I_B = 0$)	$V_{CE} = 400\text{ V}$			250	μA
$V_{(BR)EBO}$	Emitter-Base Breakdown Voltage ($I_C = 0$)	$I_E = 10\text{ mA}$	9		18	V
$V_{CEO(sus)}^*$	Collector-Emitter Sustaining Voltage ($I_B = 0$)	$I_C = 100\text{ mA}$ $L = 25\text{ mH}$	400			V
$V_{CE(sat)}^*$	Collector-Emitter Saturation Voltage	$I_C = 0.5\text{ A}$ $I_B = 0.1\text{ A}$			0.7	V
		$I_C = 1\text{ A}$ $I_B = 0.2\text{ A}$			1	V
		$I_C = 2.5\text{ A}$ $I_B = 0.5\text{ A}$		0.5	1.5	V
		$I_C = 4\text{ A}$ $I_B = 1\text{ A}$				V
$V_{BE(sat)}^*$	Base-Emitter Saturation Voltage	$I_C = 0.5\text{ A}$ $I_B = 0.1\text{ A}$			1.1	V
		$I_C = 1\text{ A}$ $I_B = 0.2\text{ A}$			1.2	V
		$I_C = 2.5\text{ A}$ $I_B = 0.5\text{ A}$			1.3	V
h_{FE}^*	DC Current Gain	$I_C = 10\text{ mA}$ $V_{CE} = 5\text{ V}$	10			
		$I_C = 2\text{ A}$ $V_{CE} = 5\text{ V}$	12		32	
t_s t_f	RESISTIVE LOAD	$V_{CC} = 200\text{ V}$ $I_C = 2\text{ A}$				
	Storage Time Fall Time	$I_{B1} = 0.4\text{ A}$ $V_{BE(off)} = -5\text{ V}$ $R_{BB} = 0\ \Omega$ $L = 200\ \mu\text{H}$ (see figure 15)		0.6 0.1		μs μs
t_s t_f	INDUCTIVE LOAD	$V_{CC} = 250\text{ V}$ $I_C = 2\text{ A}$				
	Storage Time Fall Time	$I_{B1} = 0.4\text{ A}$ $I_{B2} = -0.4\text{ A}$ $T_p = 30\ \mu\text{s}$ (see figure 14)	2	0.2	2.9	μs μs

* Pulsed: Pulsed duration = 300 μs , duty cycle $\leq 1.5\%$.

Figure 3: Safe Operating Area

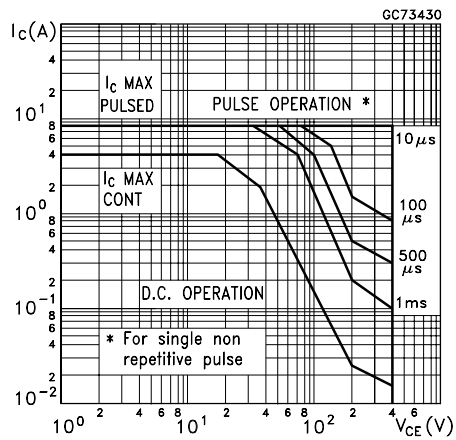

Figure 4: DC Current Gain

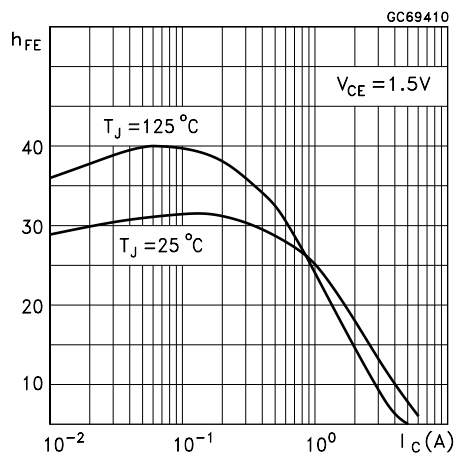

Figure 5: Collector-Emitter Saturation Voltage

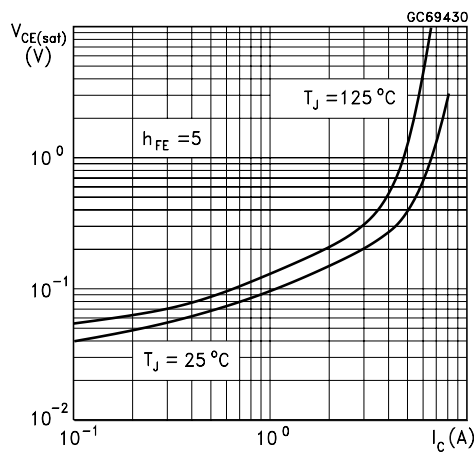

Figure 6: Derating Current

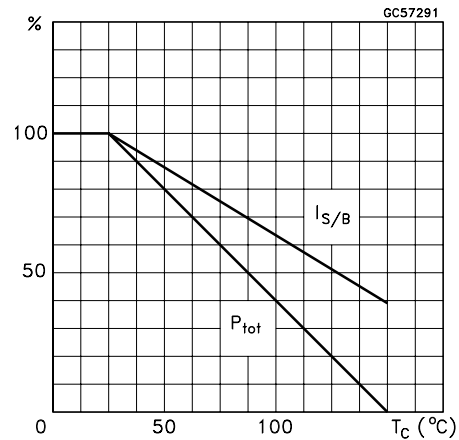

Figure 7: DC Current Gain

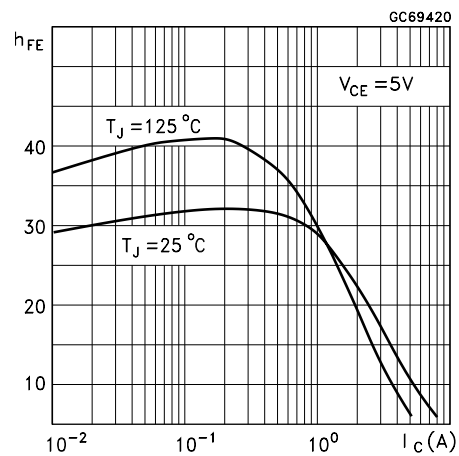

Figure 8: Base-Emitter Saturation Voltage

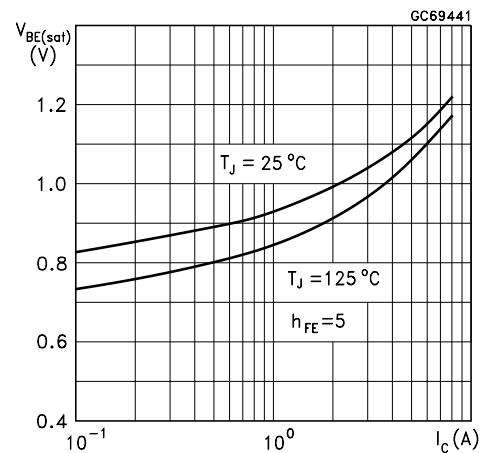

Figure 9: Inductive Load Fall Time

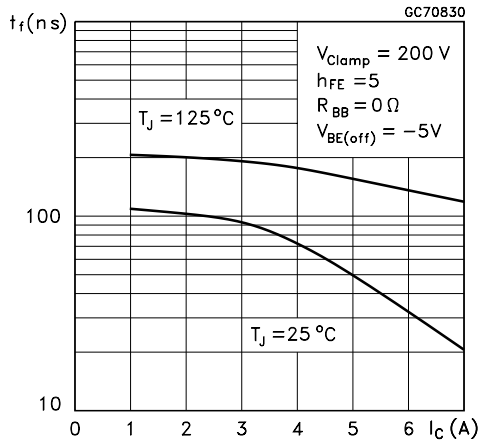

Figure 10: Resistive Load Fall Time

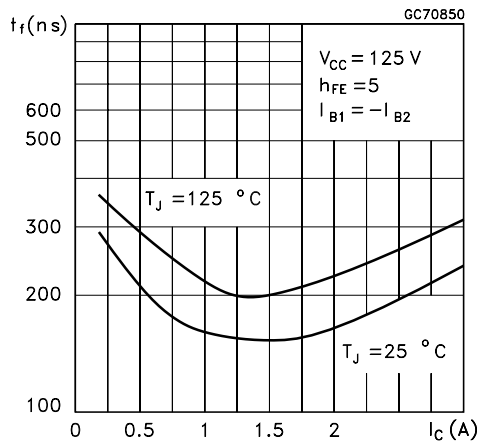

Figure 11: Reverse Biased Operating Area

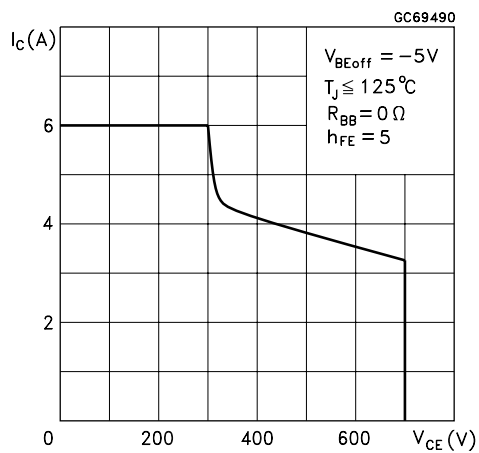

Figure 12: Inductive Load Storage Time

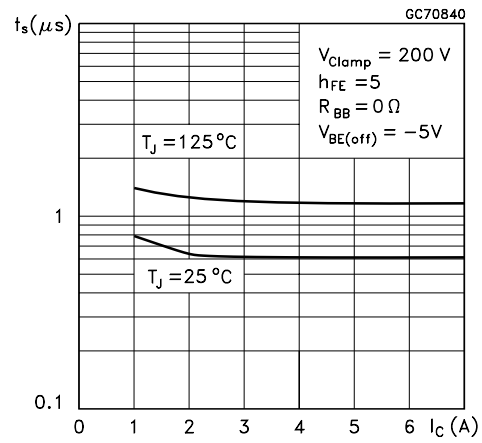

Figure 13: Resistive Load Storage Time

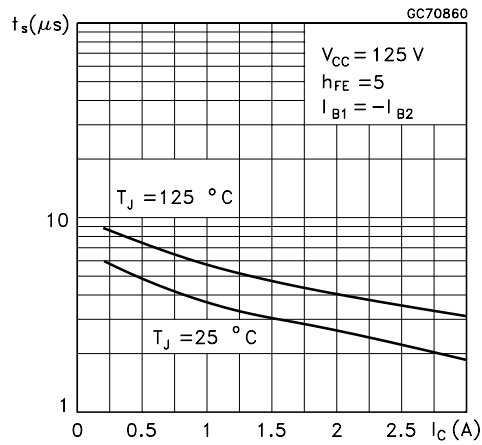

Figure 14: Inductive Load Switching Test Circuit

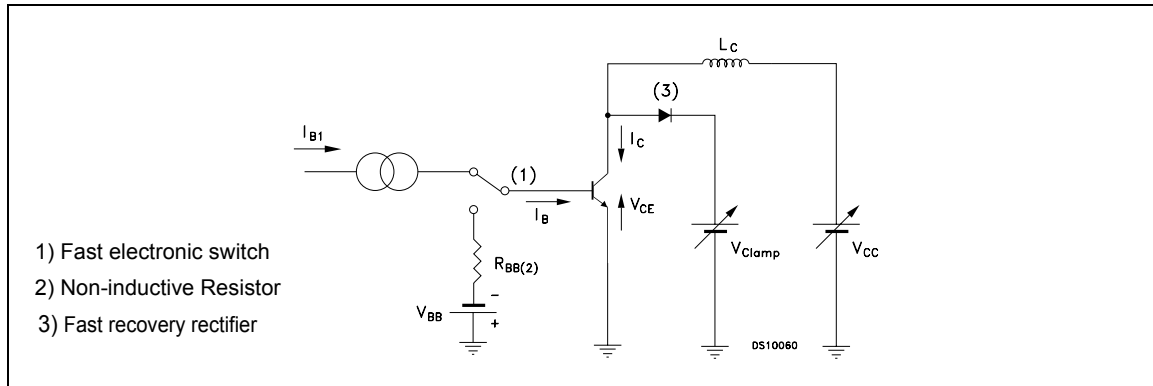
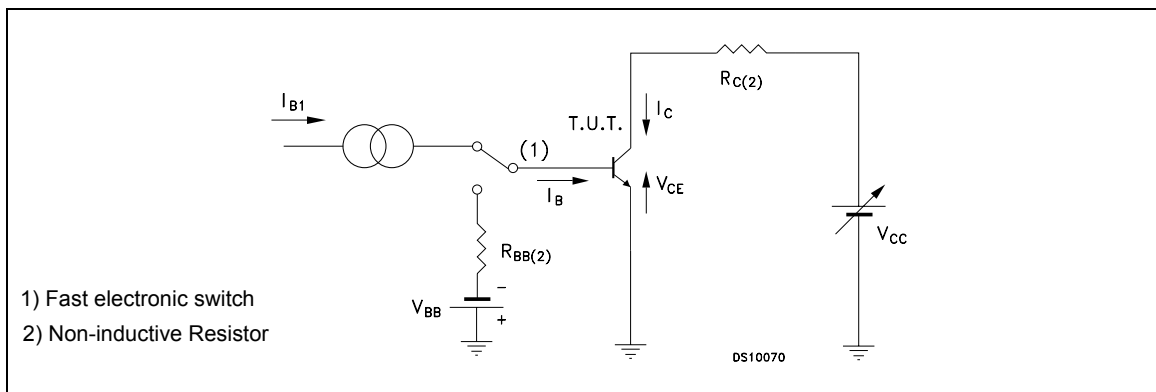

Table 15: Resistive Load Switching Test Circuit



TO-220 MECHANICAL DATA

DIM.	mm.			inch		
	MIN.	TYP.	MAX.	MIN.	TYP.	MAX.
A	4.40		4.60	0.173		0.181
b	0.61		0.88	0.024		0.034
b1	1.15		1.70	0.045		0.066
c	0.49		0.70	0.019		0.027
D	15.25		15.75	0.60		0.620
E	10		10.40	0.393		0.409
e	2.40		2.70	0.094		0.106
e1	4.95		5.15	0.194		0.202
F	1.23		1.32	0.048		0.052
H1	6.20		6.60	0.244		0.256
J1	2.40		2.72	0.094		0.107
L	13		14	0.511		0.551
L1	3.50		3.93	0.137		0.154
L20		16.40			0.645	
L30		28.90			1.137	
øP	3.75		3.85	0.147		0.151
Q	2.65		2.95	0.104		0.116

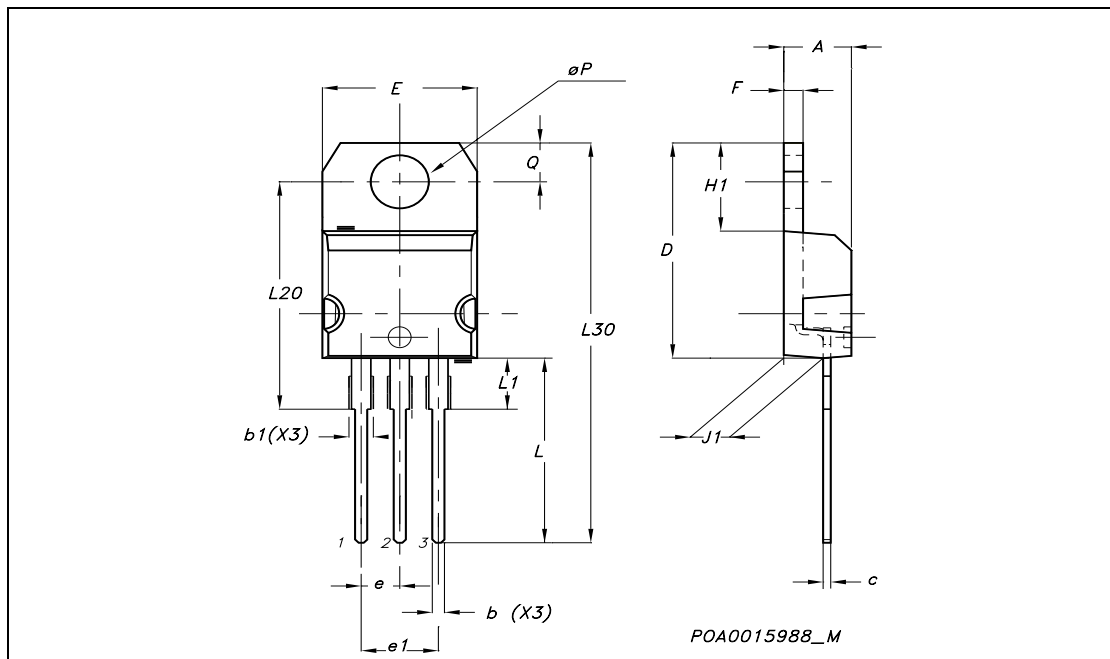

Table 5:

Version	Release Date	Change Designator
01-Oct-2002	1	First Release.
15-Feb-2005	1	Added table 1 on page 1.

Information furnished is believed to be accurate and reliable. However, STMicroelectronics assumes no responsibility for the consequences of use of such information nor for any infringement of patents or other rights of third parties which may result from its use. No license is granted by implication or otherwise under any patent or patent rights of STMicroelectronics. Specifications mentioned in this publication are subject to change without notice. This publication supersedes and replaces all information previously supplied. STMicroelectronics products are not authorized for use as critical components in life support devices or systems without express written approval of STMicroelectronics.

The ST logo is a registered trademark of STMicroelectronics
All other names are the property of their respective owners

© 2005 STMicroelectronics - All Rights Reserved

STMicroelectronics group of companies

Australia - Belgium - Brazil - Canada - China - Czech Republic - Finland - France - Germany - Hong Kong - India - Israel - Italy - Japan -
Malaysia - Malta - Morocco - Singapore - Spain - Sweden - Switzerland - United Kingdom - United States of America
www.st.com