



## STD13003

# HIGH VOLTAGE FAST-SWITCHING NPN POWER TRANSISTOR

- REVERSE PINS OUT Vs STANDARD IPAK (TO-251) / DPAK (TO-252) PACKAGES
- MEDIUM VOLTAGE CAPABILITY
- LOW SPREAD OF DYNAMIC PARAMETERS
- MINIMUM LOT-TO-LOT SPREAD FOR RELIABLE OPERATION
- VERY HIGH SWITCHING SPEED
- SURFACE-MOUNTING DPAK (TO-252) POWER PACKAGE IN TAPE & REEL (Suffix "T4")
- THROUGH-HOLE IPAK (TO-251) POWER PACKAGE IN TUBE (Suffix "-1")

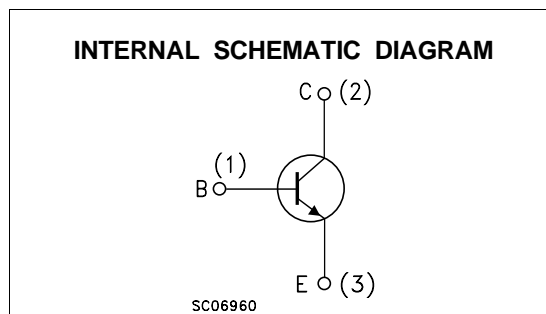
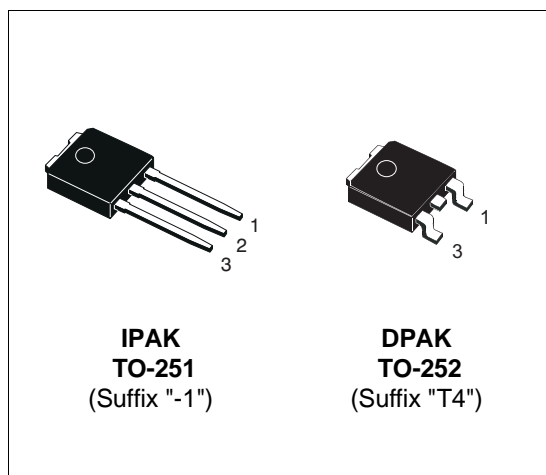
### APPLICATIONS:

- ELECTRONIC BALLASTS FOR FLUORESCENT LIGHTING
- SWITCH MODE POWER SUPPLIES

### DESCRIPTION

The device is manufactured using high voltage Multi Epitaxial Planar technology for high switching speeds and medium voltage capability. It uses a Cellular Emitter structure with planar edge termination to enhance switching speeds while maintaining the wide RBSOA.

The device is designed for use in lighting applications and low cost switch-mode power supplies.



### ABSOLUTE MAXIMUM RATINGS

Symbol	Parameter	Value	Unit
$V_{CES}$	Collector-Emitter Voltage ( $V_{BE} = 0$ )	700	V
$V_{CEO}$	Collector-Emitter Voltage ( $I_B = 0$ )	400	V
$V_{EBO}$	Emitter-Base Voltage ( $I_C = 0$ , $I_B = 0.75$ A, $t_p < 10\mu s$ , $T_j < 150^\circ C$ )	$BV_{EBO}$	V
$I_C$	Collector Current	1.5	A
$I_{CM}$	Collector Peak Current ( $t_p < 5$ ms)	3	A
$I_B$	Base Current	0.75	A
$I_{BM}$	Base Peak Current ( $t_p < 5$ ms)	1.5	A
$P_{tot}$	Total Dissipation at $T_c = 25^\circ C$	20	W
$T_{stg}$	Storage Temperature	-65 to 150	$^\circ C$
$T_j$	Max. Operating Junction Temperature	150	$^\circ C$

**THERMAL DATA**

R <sub>thj-case</sub>	Thermal Resistance Junction-case	Max	6.25	°C/W
R <sub>thj-amb</sub>	Thermal Resistance Junction-ambient	Max	100	°C/W

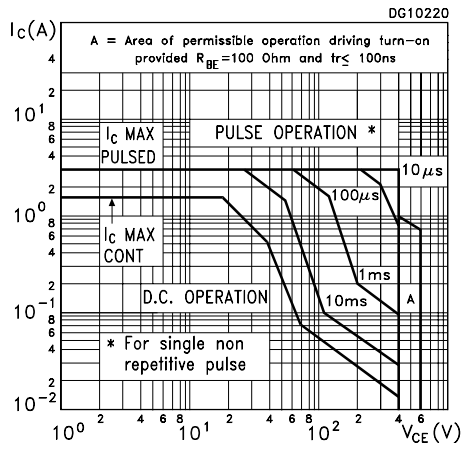
**ELECTRICAL CHARACTERISTICS** (T<sub>case</sub> = 25 °C unless otherwise specified)

Symbol	Parameter	Test Conditions	Min.	Typ.	Max.	Unit
I <sub>CEV</sub>	Collector Cut-off Current (V <sub>BE</sub> = -1.5V)	V <sub>CE</sub> = 700V V <sub>CE</sub> = 700V T <sub>j</sub> = 125°C			1 5	mA mA
BV <sub>EBO</sub>	Emitter-Base Breakdown Voltage (I <sub>C</sub> = 0)	I <sub>E</sub> = 10 mA	9		18	V
V <sub>CEO(sus)*</sub>	Collector-Emitter Sustaining Voltage (I <sub>B</sub> = 0)	I <sub>C</sub> = 10 mA L = 25 mH	400			V
V <sub>CE(sat)*</sub>	Collector-Emitter Saturation Voltage	I <sub>C</sub> = 0.5 A I <sub>C</sub> = 1 A I <sub>C</sub> = 1.5 A			0.5 1 3	V V V
V <sub>BE(sat)*</sub>	Base-Emitter Saturation Voltage	I <sub>C</sub> = 0.5 A I <sub>C</sub> = 1 A			1 1.2	V V
h <sub>FE*</sub>	DC Current Gain	I <sub>C</sub> = 0.5 A Group A Group B I <sub>C</sub> = 1 A				
t <sub>r</sub> t <sub>s</sub> t <sub>f</sub>	RESISTIVE LOAD Rise Time Storage Time Fall Time	I <sub>C</sub> = 1 A I <sub>B1</sub> = 0.2 A T <sub>p</sub> = 25 μs				
t <sub>s</sub>	INDUCTIVE LOAD Storage Time	I <sub>C</sub> = 1 A V <sub>BE</sub> = -5 V V <sub>clamp</sub> = 300 V		0.8		μs

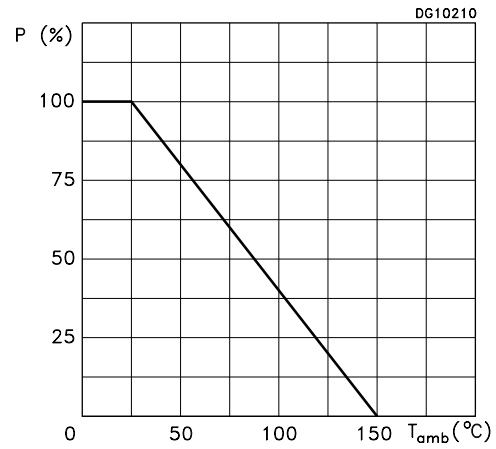
\* Pulsed: Pulse duration = 300μs, duty cycle = 1.5 %

Note : Product is pre-selected in DC current gain (GROUP A and GROUP B). STMicroelectronics reserves the right to ship either groups according to production availability. Please contact your nearest STMicroelectronics sales office for delivery details.

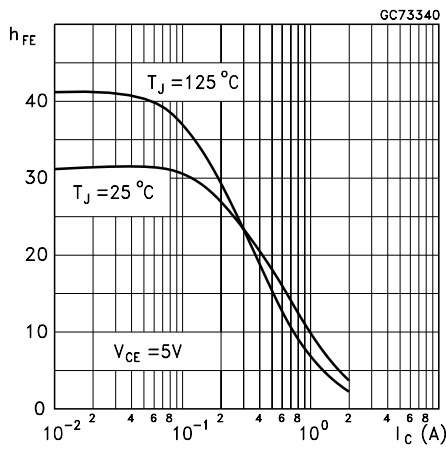
Safe Operating Areas



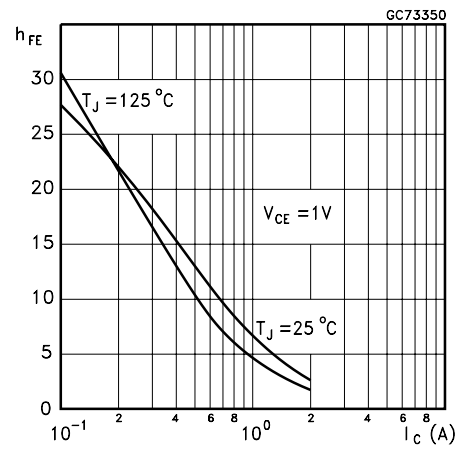
Derating Curve



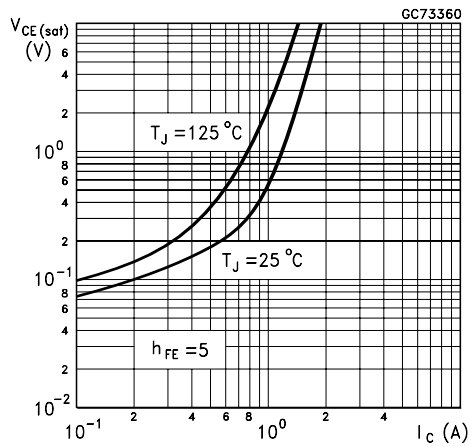
DC Current Gain



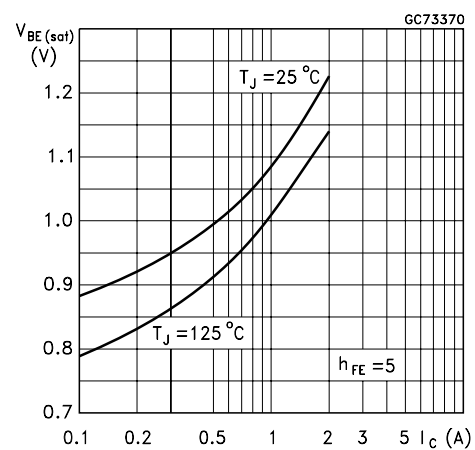
DC Current Gain



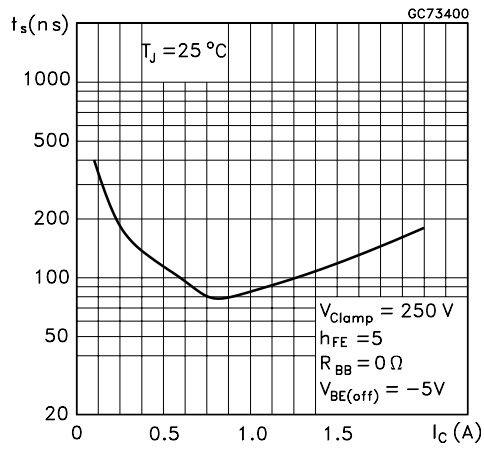
Collector Emitter Saturation Voltage



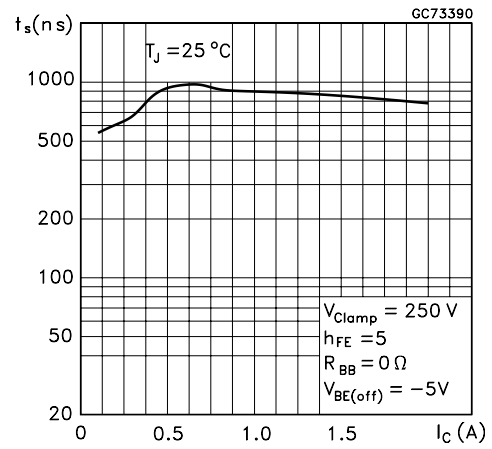
Base Emitter Saturation Voltage



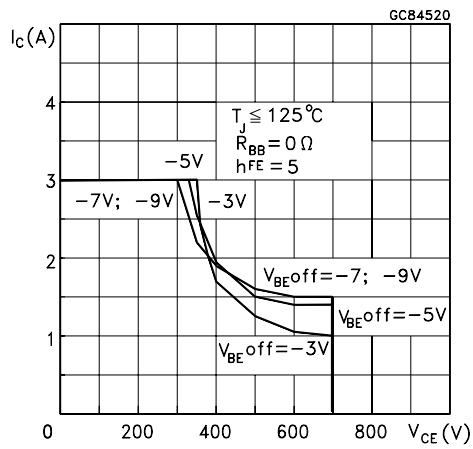
Inductive Fall Time



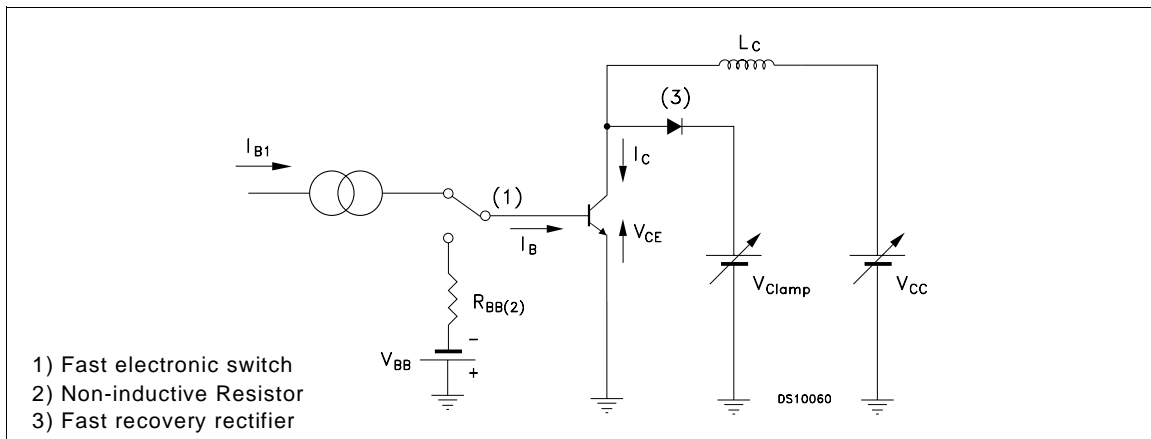
Inductive Storage Time



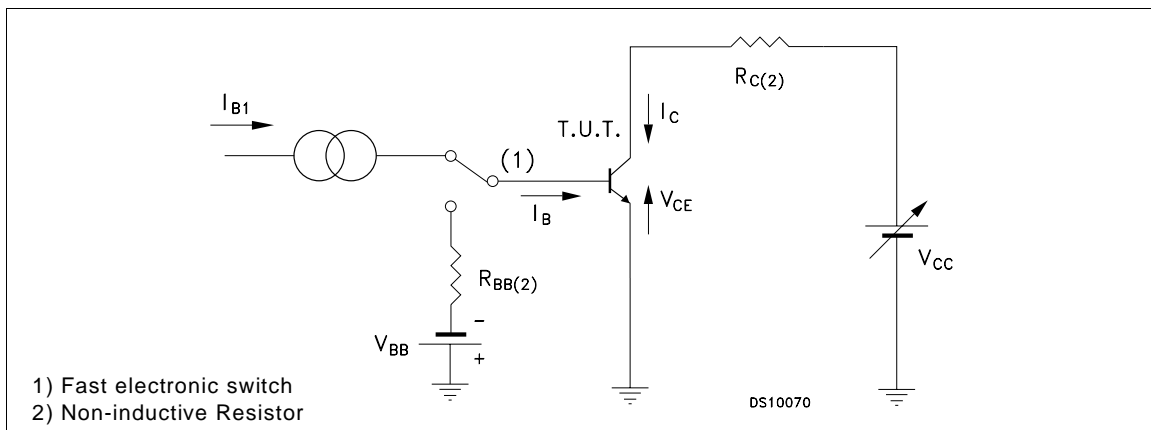
Reverse Biased SOA



**Figure 1:** Inductive Load Switching Test Circuit.

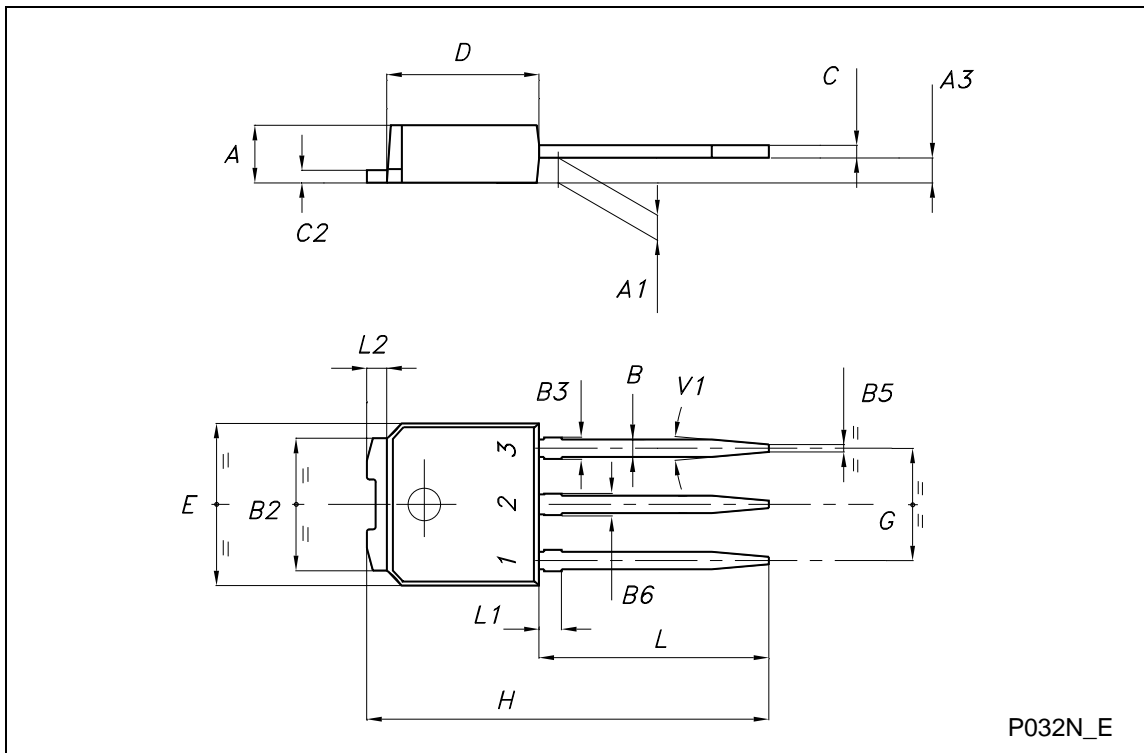


**Figure 2:** Resistive Load Switching Test Circuit.



**TO-251 (IPAK) MECHANICAL DATA**

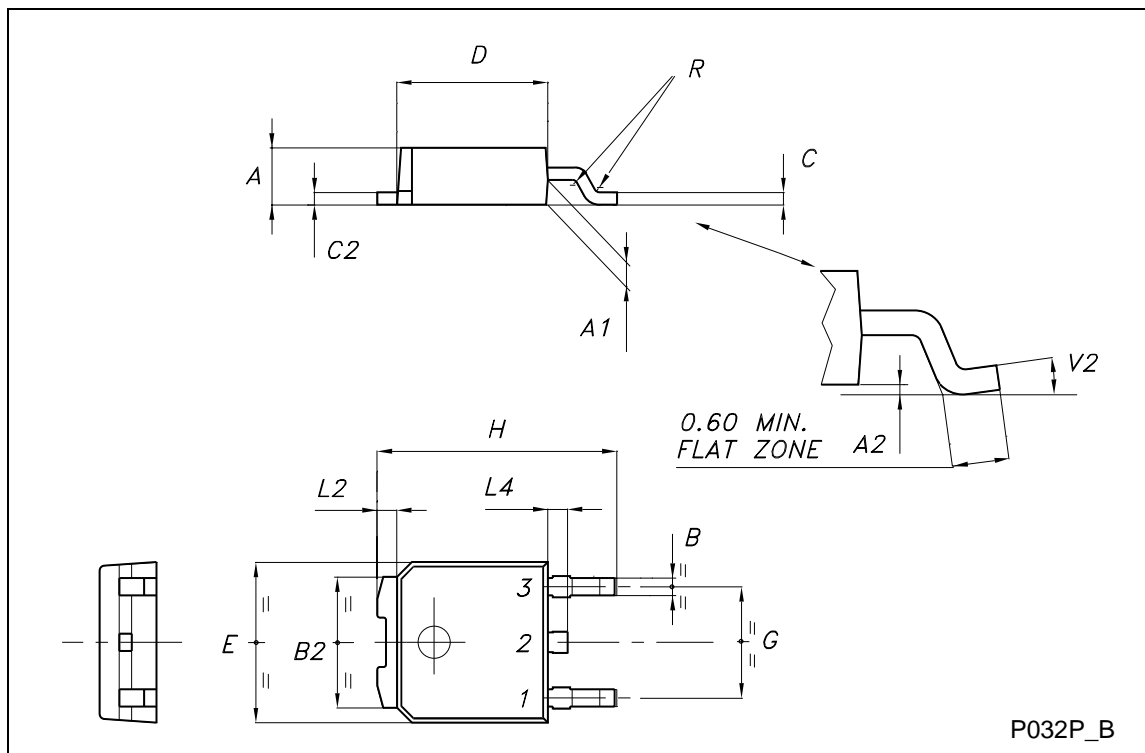
DIM.	mm			inch		
	MIN.	TYP.	MAX.	MIN.	TYP.	MAX.
A	2.20		2.40	0.087		0.094
A1	0.90		1.10	0.035		0.043
A3	0.70		1.30	0.028		0.051
B	0.64		0.90	0.025		0.035
B2	5.20		5.40	0.204		0.213
B3			0.85			0.033
B5		0.30			0.012	
B6			0.95			0.037
C	0.45		0.60	0.018		0.024
C2	0.48		0.60	0.019		0.024
D	6.00		6.20	0.237		0.244
E	6.40		6.60	0.252		0.260
G	4.40		4.60	0.173		0.181
H	15.90		16.30	0.626		0.642
L	9.00		9.40	0.354		0.370
L1	0.80		1.20	0.031		0.047
L2		0.80	1.00		0.031	0.039
V1		10°			10°	



P032N\_E

**TO-252 (DPAK) MECHANICAL DATA**

DIM.	mm			inch		
	MIN.	TYP.	MAX.	MIN.	TYP.	MAX.
A	2.20		2.40	0.087		0.094
A1	0.90		1.10	0.035		0.043
A2	0.03		0.23	0.001		0.009
B	0.64		0.90	0.025		0.035
B2	5.20		5.40	0.204		0.213
C	0.45		0.60	0.018		0.024
C2	0.48		0.60	0.019		0.024
D	6.00		6.20	0.236		0.244
E	6.40		6.60	0.252		0.260
G	4.40		4.60	0.173		0.181
H	9.35		10.10	0.368		0.398
L2		0.8			0.031	
L4	0.60		1.00	0.024		0.039
V2	0°		8°	0°		0°



Information furnished is believed to be accurate and reliable. However, STMicroelectronics assumes no responsibility for the consequences of use of such information nor for any infringement of patents or other rights of third parties which may result from its use. No license is granted by implication or otherwise under any patent or patent rights of STMicroelectronics. Specification mentioned in this publication are subject to change without notice. This publication supersedes and replaces all information previously supplied. STMicroelectronics products are not authorized for use as critical components in life support devices or systems without express written approval of STMicroelectronics.

The ST logo is a trademark of STMicroelectronics

© 2001 STMicroelectronics – Printed in Italy – All Rights Reserved  
STMicroelectronics GROUP OF COMPANIES

Australia - Brazil - China - Finland - France - Germany - Hong Kong - India - Italy - Japan - Malaysia - Malta - Morocco -  
Singapore - Spain - Sweden - Switzerland - United Kingdom - U.S.A.

<http://www.st.com>