



STL73

MEDIUM VOLTAGE FAST-SWITCHING NPN POWER TRANSISTOR

- n MEDIUM VOLTAGE CAPABILITY
- n LOW SPREAD OF DYNAMIC PARAMETERS
- n MINIMUM LOT-TO-LOT SPREAD FOR RELIABLE OPERATION
- n VERY HIGH SWITCHING SPEED

APPLICATIONS

- n COMPACT FLUORESCENT LAMPS (CFLS)

DESCRIPTION

The device is manufactured using high voltage Multi-Epitaxial Planar technology for high switching speeds and medium voltage capability.

It uses a Cellular Emitter structure with planar edge termination to enhance switching speeds while maintaining the wide RBSOA.

The STL series is designed for use in Compact Fluorescent Lamps.

Figure 1: Package

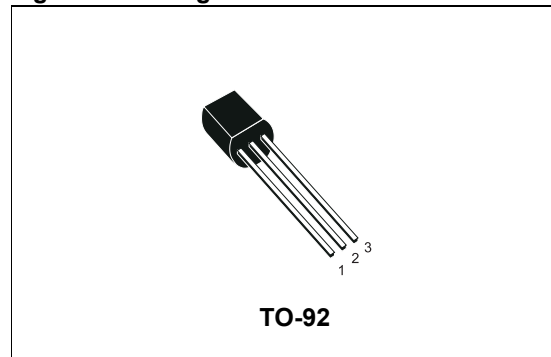

Figure 2: Internal Schematic Diagram

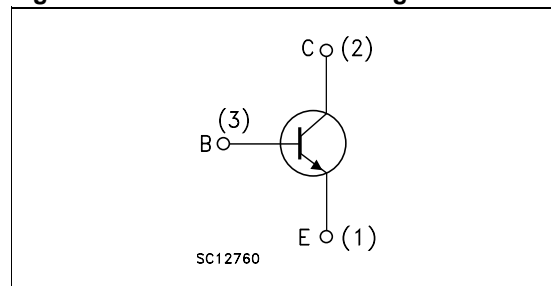

Table 1: Order Codes

Part Number	Marking	Package	Packaging
STL73	L73 L or (#) L73 H	TO-92	Bulk

See:note on page 2

STL73

Table 2: Absolute Maximum Ratings

Symbol	Parameter	Value	Unit
V_{CES}	Collector-Emitter Voltage ($V_{BE} = 0$)	700	V
V_{CEO}	Collector-Emitter Voltage ($I_B = 0$)	400	V
V_{EBO}	Emitter-Base Voltage ($I_C = 0$)	$V_{(BR)EBO}$	V
I_C	Collector Current	1.5	A
I_{CM}	Collector Peak Current ($t_p < 5\text{ms}$)	3	A
I_B	Base Current	0.5	A
I_{BM}	Base Peak Current ($t_p < 5\text{ms}$)	1.5	A
P_{tot}	Total Dissipation at $T_C = 25\text{ }^\circ\text{C}$	1.1	W
T_{stg}	Storage Temperature	-65 to 150	$^\circ\text{C}$
T_J	Max. Operating Junction Temperature	150	$^\circ\text{C}$

Table 3: Thermal Data

$R_{thj-amb}$	Thermal Resistance Junction-Ambient	Max	112	$^\circ\text{C/W}$
---------------	-------------------------------------	-----	-----	--------------------

Table 4: Electrical Characteristics ($T_{case} = 25\text{ }^\circ\text{C}$ unless otherwise specified)

Symbol	Parameter	Test Conditions	Min.	Typ.	Max.	Unit
I_{CEV}	Collector Cut-off Current ($V_{BE} = -1.5\text{ V}$)	$V_{CE} = 700\text{ V}$			1	mA
		$V_{CE} = 700\text{ V}$	$T_J = 125\text{ }^\circ\text{C}$		5	mA
$V_{(BR)EBO}$	Emitter-Base Breakdown Voltage ($I_C = 0$)	$I_E = 10\text{ mA}$	9		18	V
$V_{CEO(sus)}^*$	Collector-Emitter Sustaining Voltage ($I_B = 0$)	$I_C = 10\text{ mA}$	400			V
$V_{CE(sat)}^*$	Collector-Emitter Saturation Voltage	$I_C = 0.3\text{ A}$		0.15	0.4	V
		$I_C = 0.6\text{ A}$	$I_B = 120\text{ mA}$	0.25	0.6	V
		$I_C = 1\text{ A}$	$I_B = 250\text{ mA}$	0.4	1	V
$V_{BE(sat)}^*$	Base-Emitter Saturation Voltage	$I_C = 0.6\text{ A}$		0.95	1.1	V
h_{FE}	DC Current Gain #	$I_C = 0.6\text{ A}$	$V_{CE} = 3\text{ V}$			
		Group L		10	16	
		Group H		15	21	
t_f	RESISTIVE LOAD	$I_C = 1$	$V_{CC} = 125\text{ V}$			
		$I_{B1} = -I_{B2} = 200\text{ mA}$	$t_p = 25\text{ }\mu\text{s}$		1	μs
		(see figure 4)			4	μs
t_f	INDUCTIVE LOAD	$I_C = 0.3$	$V_{Clamp} = 300\text{ V}$			
		$I_{B1} = -I_{B2} = 60\text{ mA}$	$L = 3\text{ mH}$		0.3	μs
		(see figure 3)				

* Pulsed: Pulsed duration = 300 μs , duty cycle $\leq 1.5\%$.

The product is pre-selected in DC current gain (Group L and Group H). STMicroelectronics reserves the right to ship either groups according to production availability. Please contact your nearest STMicroelectronics sales office for delivery details.

Figure 3: Inductive Load Switching Test Circuit

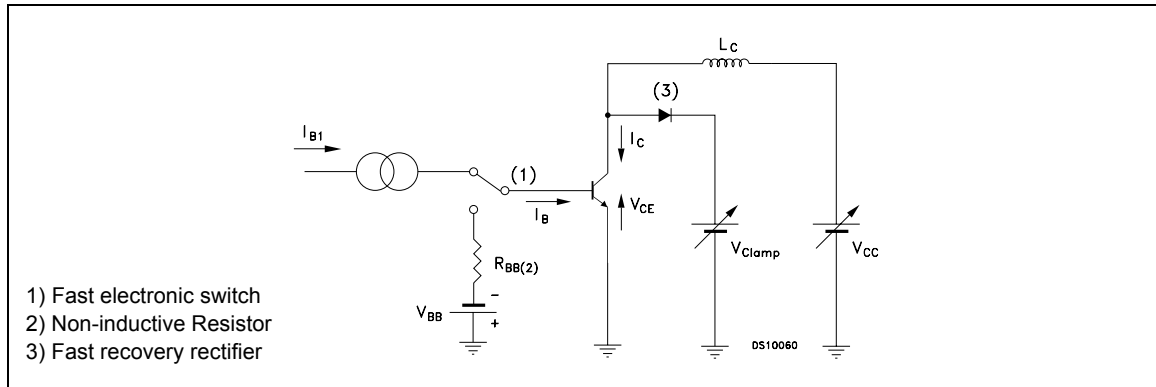
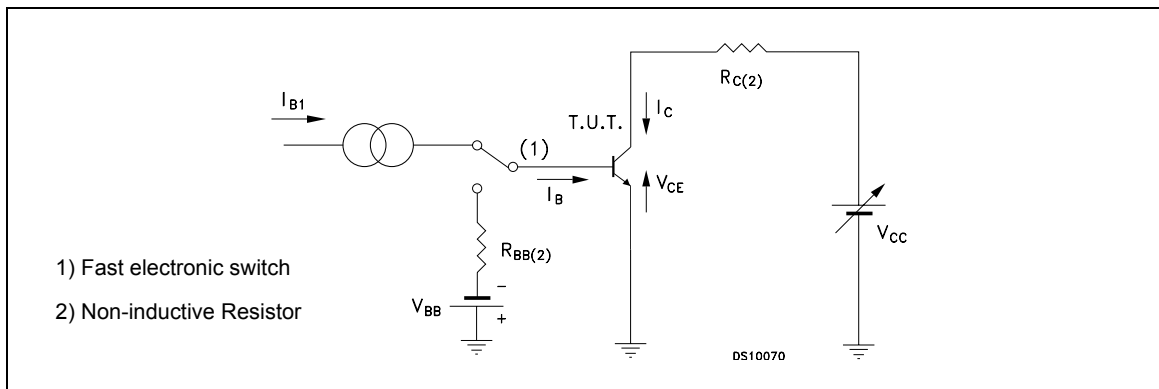

Figure 4: Resistive Load Switching Test Circuit



TO-92 BULK SHIPMENT MECHANICAL DATA

DIM.	mm.		
	MIN.	TYP	MAX.
A	4.32		4.95
b	0.36		0.51
D	4.45		4.95
E	3.30		3.94
e	2.41		2.67
e1	1.14		1.40
L	12.70		15.49
R	2.16		2.41
S1	0.92		1.52
W	0.41		0.56
V		5°	

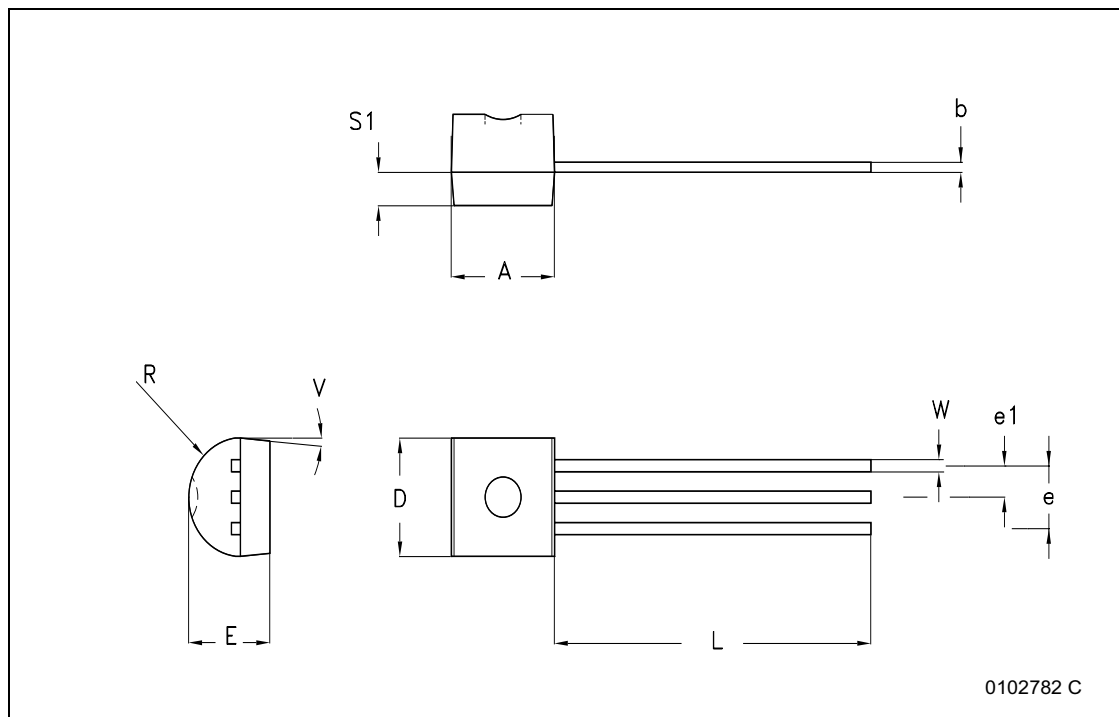

Figure 5: Revision History

Release Date	Version	Change Designator
11-Jul-2005	1	First Release.

Information furnished is believed to be accurate and reliable. However, STMicroelectronics assumes no responsibility for the consequences of use of such information nor for any infringement of patents or other rights of third parties which may result from its use. No license is granted by implication or otherwise under any patent or patent rights of STMicroelectronics. Specifications mentioned in this publication are subject to change without notice. This publication supersedes and replaces all information previously supplied. STMicroelectronics products are not authorized for use as critical components in life support devices or systems without express written approval of STMicroelectronics.

The ST logo is a registered trademark of STMicroelectronics

All other names are the property of their respective owners

© 2005 STMicroelectronics - All Rights Reserved

STMicroelectronics group of companies

Australia - Belgium - Brazil - Canada - China - Czech Republic - Finland - France - Germany - Hong Kong - India - Israel - Italy - Japan -
Malaysia - Malta - Morocco - Singapore - Spain - Sweden - Switzerland - United Kingdom - United States of America

www.st.com