

NPN SILICON PLANAR MEDIUM POWER HIGH GAIN TRANSISTOR

ZTX688B

ISSUE 2 – MAY 94

FEATURES

- * 12 Volt V_{CEO}
- * Gain of 400 at $I_C=3$ Amps
- * Very low saturation voltage

APPLICATIONS

- * Darlingtion replacement
- * Flash gun convertors
- * Battery powered circuits
- * Motor drivers

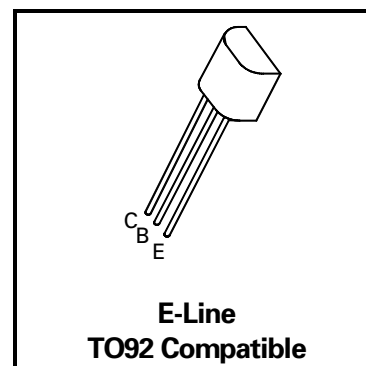

ABSOLUTE MAXIMUM RATINGS.

PARAMETER	SYMBOL	VALUE	UNIT
Collector-Base Voltage	V_{CBO}	12	V
Collector-Emitter Voltage	V_{CEO}	12	V
Emitter-Base Voltage	V_{EBO}	5	V
Peak Pulse Current	I_{CM}	10	A
Continuous Collector Current	I_C	3	A
Practical Power Dissipation*	P_{totp}	1.5	W
Power Dissipation at $T_{amb}=25^{\circ}C$ derate above $25^{\circ}C$	P_{tot}	1 5.7	W mW/ $^{\circ}C$
Operating and Storage Temperature Range	$T_j; T_{stg}$	-55 to +200	$^{\circ}C$

*The power which can be dissipated assuming the device is mounted in a typical manner on a P.C.B. with copper equal to 1 inch square minimum

ELECTRICAL CHARACTERISTICS (at $T_{amb} = 25^{\circ}C$)

PARAMETER	SYMBOL	MIN.	TYP.	MAX.	UNIT	CONDITIONS.
Collector-Base Breakdown Voltage	$V_{(BR)CBO}$	12			V	$I_C=100\mu A$
Collector-Emitter Breakdown Voltage	$V_{(BR)CEO}$	12			V	$I_C=10mA^*$
Emitter-Base Breakdown Voltage	$V_{(BR)EBO}$	5			V	$I_E=100\mu A$
Collector Cut-Off Current	I_{CBO}			0.1	μA	$V_{CB}=10V$
Emitter Cut-Off Current	I_{EBO}			0.1	μA	$V_{EB}=4V$
Collector-Emitter Saturation Voltage	$V_{CE(sat)}$			0.04 0.06 0.18 0.35	V V V V	$I_C=0.1A, I_B=1mA$ $I_C=0.1A, I_B=0.5mA^*$ $I_C=1A, I_B=50mA^*$ $I_C=3A, I_B=20mA^*$
Base-Emitter Saturation Voltage	$V_{BE(sat)}$			1.1	V	$I_C=3A, I_B=20mA^*$
Base-Emitter Turn-On Voltage	$V_{BE(on)}$			1	V	$I_C=3A, V_{CE}=2V^*$
Static Forward Current Transfer Ratio	h_{FE}	500 400 100				$I_C=0.1A, V_{CE}=2V^*$ $I_C=3A, V_{CE}=2V^*$ $I_C=10A, V_{CE}=2V^*$

ZTX688B

ELECTRICAL CHARACTERISTICS (at $T_{amb} = 25^{\circ}\text{C}$)

PARAMETER	SYMBOL	MIN.	TYP.	MAX.	UNIT	CONDITIONS.
Transition Frequency	f_T	150			MHz	$I_C=50\text{mA}$, $V_{CE}=5\text{V}$ $f=50\text{MHz}$
Input Capacitance	C_{ibo}		200		pF	$V_{EB}=0.5\text{V}$, $f=1\text{MHz}$
Output Capacitance	C_{obo}		40		pF	$V_{CB}=10\text{V}$, $f=1\text{MHz}$
Switching Times	t_{on} t_{off}		40 500		ns ns	$I_C=50\text{mA}$, $I_{B1}=50\text{mA}$ $I_{B2}=50\text{mA}$, $V_{CC}=10\text{V}$

*Measured under pulsed conditions. Pulse width=300 μs . Duty cycle $\leq 2\%$

THERMAL CHARACTERISTICS

PARAMETER	SYMBOL	MAX.	UNIT
Thermal Resistance: Junction to Ambient ₁	$R_{th(j-amb)1}$	175	$^{\circ}\text{C/W}$
Junction to Ambient ₂	$R_{th(j-amb)2}^{\dagger}$	116	$^{\circ}\text{C/W}$
Junction to Case	$R_{th(j-case)}$	70	$^{\circ}\text{C/W}$

\dagger Device mounted on P.C.B. with copper equal to 1 sq. Inch minimum.

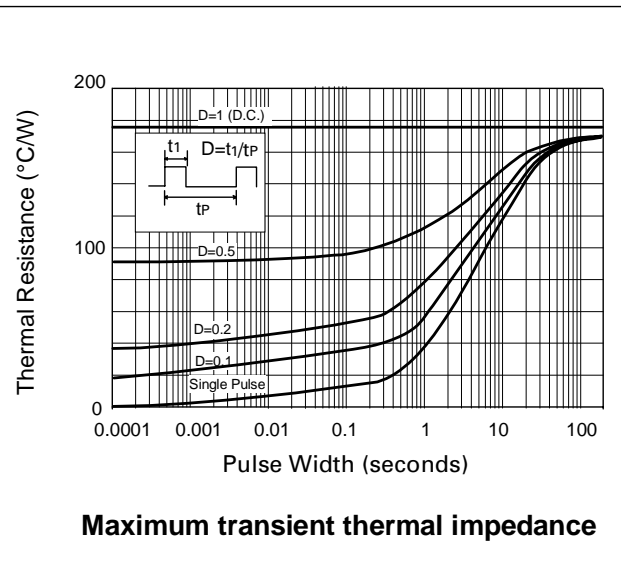
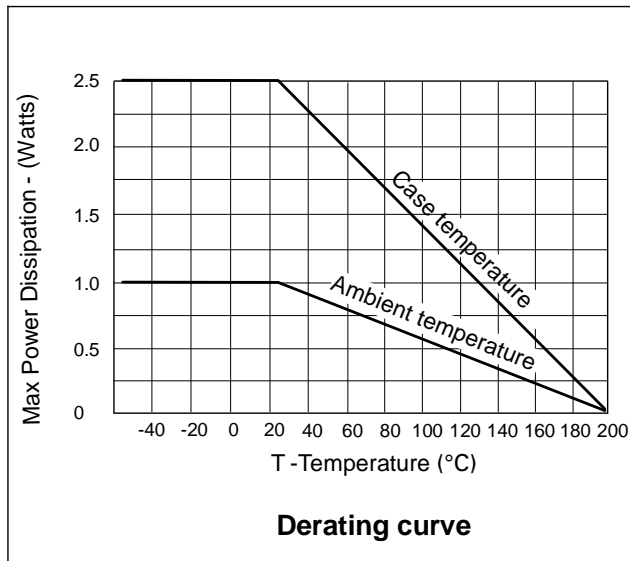

ZTX688B

TYPICAL CHARACTERISTICS

