

Powerex, Inc., 200 Hillis Street, Youngwood, Pennsylvania 15697-1800 (412) 925-7272  
 Powerex, Europe, S.A. 428 Avenue G. Durand, BP107, 72003 Le Mans, France (43) 41.14.14

**Phase Control SCR**  
 310 Amperes Average  
 1600 Volts

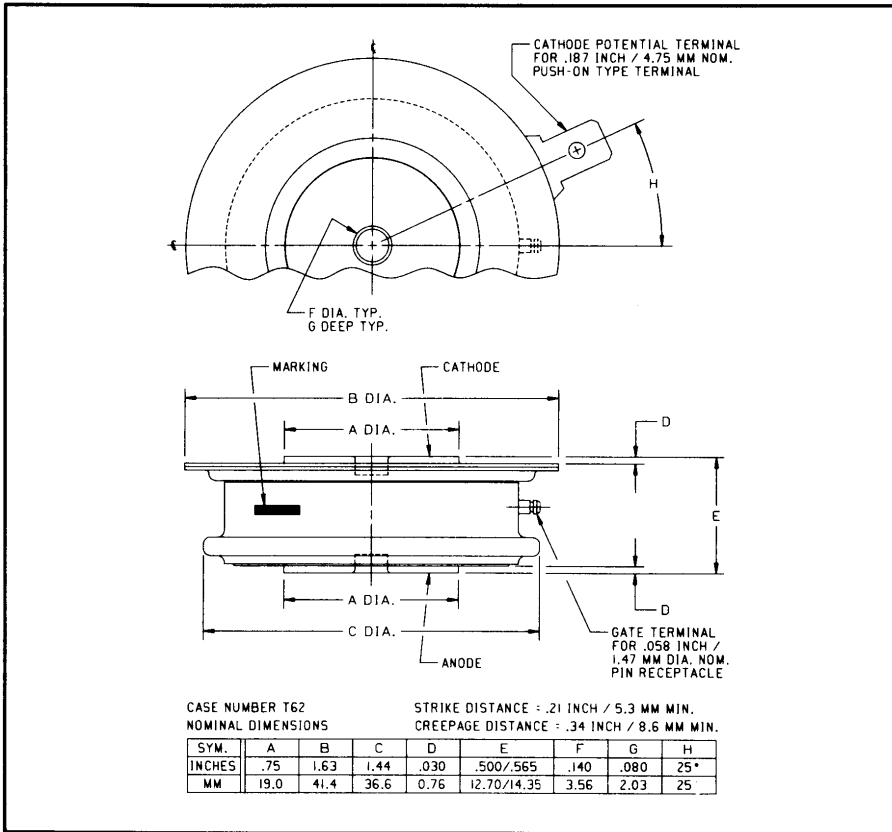

C380\_\_X500 (Outline Drawing)

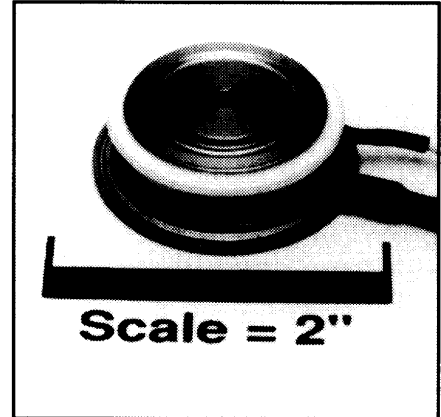

C380\_\_X500 Phase Control SCR  
 310 Amperes Average, 1600 Volts

### Ordering Information:

Select the complete nine digit part number you desire from the table, i.e. C380PMX500 is a 1600 Volt, 310 Ampere Phase Control SCR.

Type	Voltage		Current
	V <sub>DRM</sub> V <sub>RRM</sub>	Code	
C380__X500	200	B	310
	400	D	
	600	M	
	800	N	
	1000	P	
	1200	PB	
	1400	PD	
	1600	PM	

### Description:

Powerex Silicon Controlled Rectifiers (SCR) are designed for phase control applications. These are all-diffused, Press-Pak (Pow-R-Disc) devices employing the field-proven amplifying (di/namic) gate.

### Features:

- Low On-State Voltage
- High di/dt
- High dv/dt
- Hermetic Packaging
- Excellent Surge and I<sup>2</sup>t Ratings

### Applications:

- Power Supplies
- Battery Chargers

C380\_X500  
 Phase Control SCR  
 310 Amperes Average, 1600 Volts

## Absolute Maximum Ratings

	Symbol	C380_X500	Units
RMS On-State Current @ $T_C = 83^\circ\text{C}$	$I_{T(RMS)}$	500	Amperes
Average On-State Current @ $T_C = 83^\circ\text{C}$	$I_{T(av)}$	310	Amperes
Peak One-Cycle Surge (Non-Repetitive) On-State Current (60Hz)	$I_{TSM}$	5500	Amperes
Peak One-Cycle Surge (Non-Repetitive) On-State Current (50Hz)	$I_{TSM}$	5000	Amperes
Critical Rate-of-Rise of On-State Current (Non-Repetitive)	di/dt	800	Amperes/ $\mu\text{s}$
Critical Rate-of-Rise of On-State Current (Repetitive)	di/dt	500	Amperes/ $\mu\text{s}$
$I^2t$ (for Fusing), One Cycle at 60Hz	$I^2t$	125,000	$\text{A}^2\text{sec}$
Peak Gate Power Dissipation	$P_{GM}$	10	Watts
Average Gate Power Dissipation	$P_{G(av)}$	2	Watts
Storage Temperature	$T_{STG}$	-40 to 150	$^\circ\text{C}$
Operating Temperature	$T_J$	-40 to 125	$^\circ\text{C}$
Mounting Force		720 to 880	lb.
Mounting Force		3.2 to 3.92	kN

## Electrical and Thermal Characteristics

Characteristics	Symbol	Test Conditions	C380_X500	Units
<b>Voltage—Blocking State Maximums</b>				
Forward Leakage, Peak	$I_{DRM}$	$T_J = 125^\circ\text{C}, V = V_{DRM}$	20	mA
Reverse Leakage, Peak	$I_{RRM}$	$T_J = 125^\circ\text{C}, V = V_{RRM}$	20	mA
<b>Current—Conducting State Maximums</b>				
Peak On-State Voltage	$V_{TM}$	$T_C = 125^\circ\text{C}, I_{TM} = 1500\text{A}, \text{Duty Cycle} = 0.01\%$	1.75	Volts
<b>Switching</b>				
Typical Turn-On Delay	$t_d$	$T_C = 25^\circ\text{C}, I_T = 100\text{A}, V_{DRM} = \text{rated}.$ Gate Supply 10V Open Circuit, 25 $\Omega$ , 0.1 $\mu\text{sec}$ max. rise time	1	$\mu\text{sec}$
Min. Critical dv/dt exponential to $V_{DRM}$	dv/dt	$T_J = 125^\circ\text{C}, \text{Gate open circuited}.$	200	V/ $\mu\text{sec}$
<b>Thermal</b>				
Maximum Thermal Resistance, double sided cooling				
Junction to Case	$R_{\theta JC}$		0.095	$^\circ\text{C}/\text{Watt}$
Case to Sink, Lubricated	$R_{\theta CS}$		0.02	$^\circ\text{C}/\text{Watt}$
<b>Gate—Maximum Parameters</b>				
Gate Current to Trigger	$I_{GT}$	$T_C = 25^\circ\text{C}, V_D = 6\text{V}, R_L = 3 \Omega$	150	mA
Gate Voltage to Trigger	$V_{GT}$	$T_C = -40^\circ\text{C} \text{ to } 125^\circ\text{C}, V_D = 6\text{V}, R_L = 3 \Omega$	3.0	Volts
Non-Triggering Gate Voltage	$V_{GDM}$	$T_J = 125^\circ\text{C}, \text{Rated } V_{DRM}, R_L = 1000 \Omega$	0.15	Volts
Peak Forward Gate Current	$I_{GTM}$		10	Amperes
Peak Reverse Gate Voltage	$V_{GRM}$		5	Volts

Powerex, Inc., 200 Hillis Street, Youngwood, Pennsylvania 15697-1800 (412) 925-7272  
 Powerex, Europe, S.A. 428 Avenue G. Durand, BP107, 72003 Le Mans, France (43) 41.14.14

**C380\_X500**  
**Phase Control SCR**  
 310 Amperes Average, 1600 Volts

**MAXIMUM ON-STATE CHARACTERISTICS**

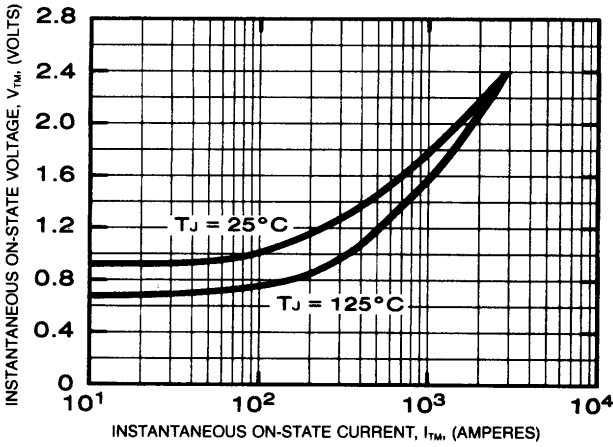

**TRANSIENT THERMAL IMPEDANCE CHARACTERISTICS (JUNCTION TO CASE)**

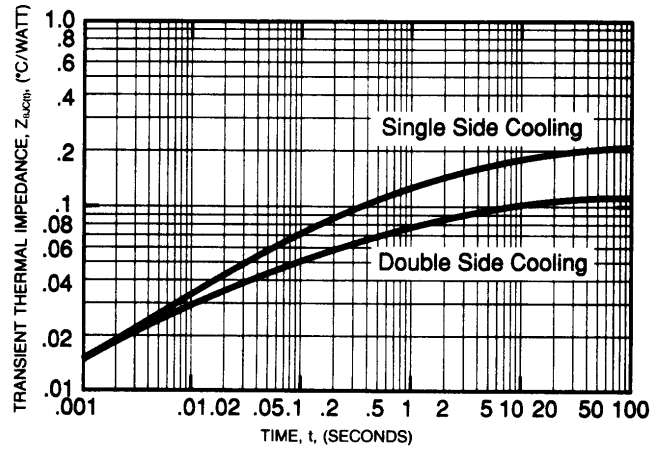

**MAXIMUM ALLOWABLE CASE TEMPERATURE (SINUSOIDAL WAVEFORM)**

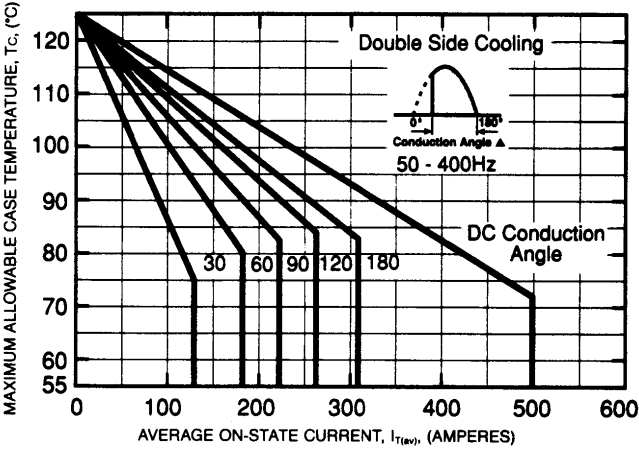

**MAXIMUM ON-STATE POWER DISSIPATION (SINUSOIDAL WAVEFORM)**

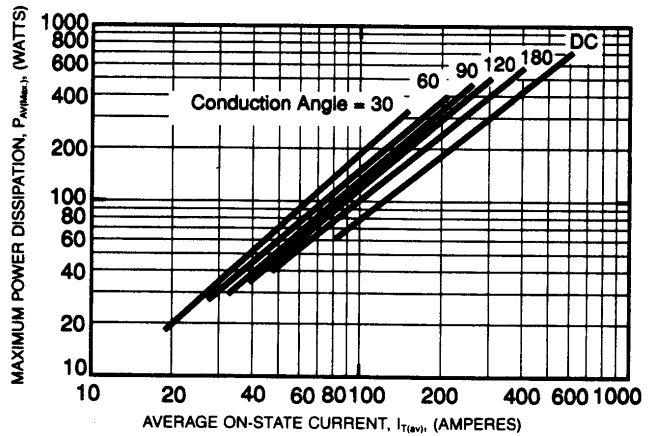

**MAXIMUM ALLOWABLE CASE TEMPERATURE (RECTANGULAR WAVEFORM)**

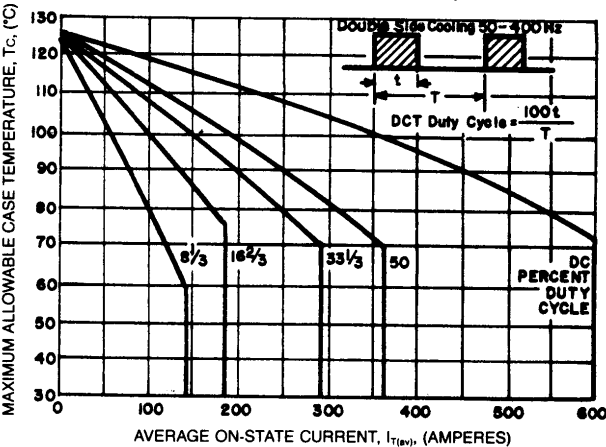

**MAXIMUM ON-STATE POWER DISSIPATION (RECTANGULAR WAVEFORM)**

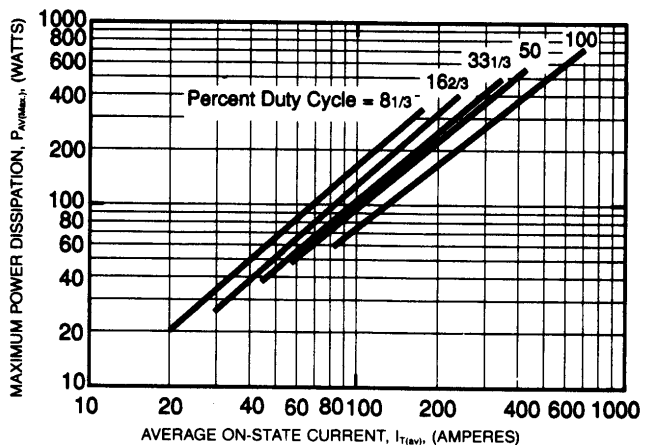

Powerex, Inc., 200 Hillis Street, Youngwood, Pennsylvania 15697-1800 (412) 925-7272  
 Powerex, Europe, S.A. 428 Avenue G. Durand, BP107, 72003 Le Mans, France (43) 41.14.14

C380\_X500

Phase Control SCR

310 Amperes Average, 1600 Volts

SUB-CYCLE SURGE AND  $I^2t$  RATINGS  
 (RATED LOAD CONDITIONS)

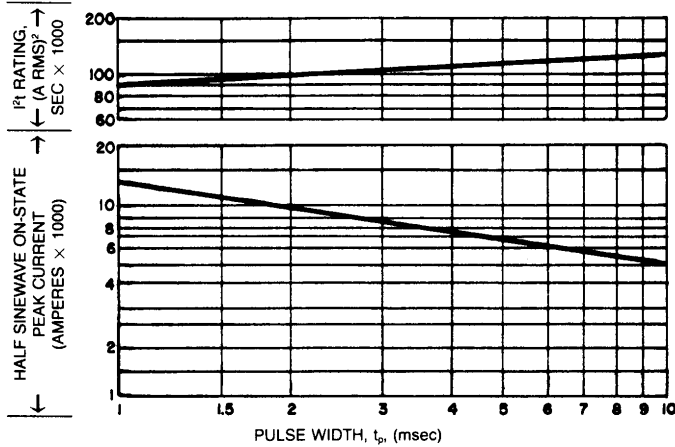

GATE CHARACTERISTICS

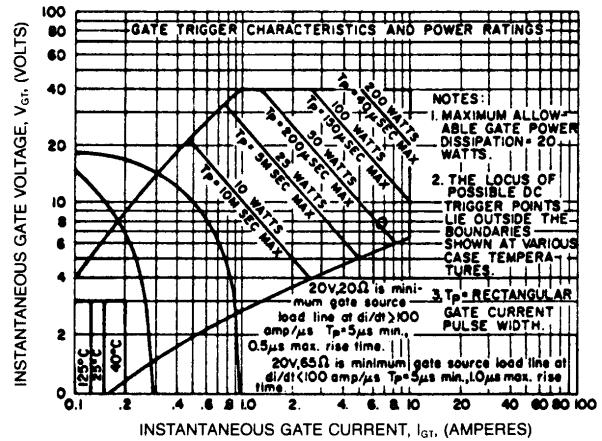

- NOTES:
1. Maximum allowable gate power dissipation = 20 watts.
  2. The locus of possible DC trigger points lie outside the boundaries shown at various case temperatures.
  3.  $T_p$  = Rectangular Gate Current Pulse Width.