



SD1433

RF POWER BIPOLAR TRANSISTORS UHF MOBILE APPLICATIONS

FEATURES SUMMARY

- 470 MHz
- 12.5 VOLTS
- CLASS C
- EFFICIENCY 60%
- COMMON EMITTER
- $P_{OUT} = 10 \text{ W MIN. WITH } 8.0 \text{ dB GAIN}$

DESCRIPTION

The SD1433 is a Class C epitaxial silicon NPN planar transistor designed for driver applications in the 450 - 512 MHz frequency range. This device uses an emitter ballasted geometry specifically designed for optimum stable power gain, maximum efficiency and infinite VSWR.

Figure 1. Package

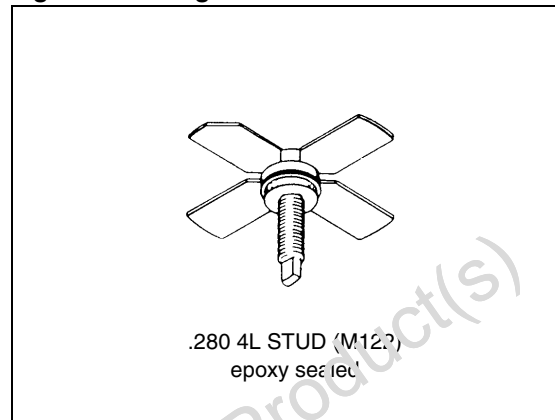

Figure 2. Pin Connection

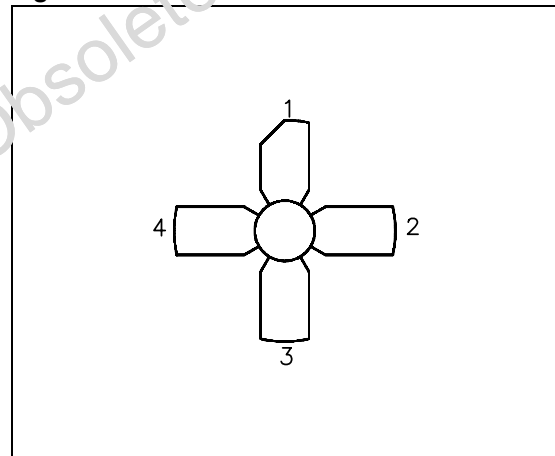

Table 1. Order Codes

Order Codes	Marking	Package	Packaging
SD1433	SD1433	M122	BLACK CARDBOARDS

SD1433

Table 2. Absolute Maximum Ratings ($T_{\text{case}} = 25^{\circ}\text{C}$)

Symbol	Parameter	Value	Unit
V_{CBO}	Collector-Base Voltage	36	V
V_{CEO}	Collector-Emitter Voltage	16	V
V_{CES}	Collector-Emitter Voltage	36	V
V_{EBO}	Emitter-Base Voltage	4.0	V
I_{C}	Device Current	2.5	A
P_{DISS}	Power Dissipation	58	W
T_{J}	Junction Temperature	+200	$^{\circ}\text{C}$
T_{STG}	Storage Temperature	- 65 to +150	$^{\circ}\text{C}$

Table 3. Thermal Data

Symbol	Parameter	Value	Unit
$R_{\text{TH(j-c)}}$	Junction-Case Thermal Resistance	3.0	$^{\circ}\text{C/W}$

ELECTRICAL SPECIFICATIONS ($T_{\text{CASE}} = 25^{\circ}\text{C}$)

Table 4. Static

Symbol	Test Conditions	Value			Unit
		Min.	Typ.	Max.	
BV_{CES}	$I_{\text{C}} = 25 \text{ mA}; V_{\text{BE}} = 0 \text{ V}$	36	—	—	V
BV_{CEO}	$I_{\text{C}} = 20 \text{ mA}; I_{\text{B}} = 0 \text{ mA}$	16	—	—	V
BV_{EBO}	$I_{\text{E}} = 10 \text{ mA}; I_{\text{C}} = 0 \text{ mA}$	4.0	—	—	V
I_{CES}	$V_{\text{CE}} = 10 \text{ V}; I_{\text{E}} = 0 \text{ mA}$	—	—	3	mA
I_{CBO}	$V_{\text{CB}} = 15 \text{ V}; I_{\text{E}} = 0 \text{ mA}$	—	—	2	mA
h_{FE}	$V_{\text{CE}} = 5 \text{ V}; I_{\text{C}} = 1 \text{ A}$	10	—	—	—

Table 5. Dynamic

Symbol	Test Conditions	Value			Unit
		Min.	Typ.	Max.	
P_{OUT}	$f = 470 \text{ MHz}; P_{\text{IN}} = 2.0 \text{ W}; V_{\text{CE}} = 12.5 \text{ V}$	10	—	—	W
G_{P}	$f = 470 \text{ MHz}; P_{\text{OUT}} = 10 \text{ W}; V_{\text{CE}} = 12.5 \text{ V}$	7	—	—	dB
C_{OB}	$f = 1 \text{ MHz}; V_{\text{CB}} = 12.5 \text{ V}$	—	19	—	pF

TYPICAL PERFORMANCE

Figure 3. Power Output vs Power Input

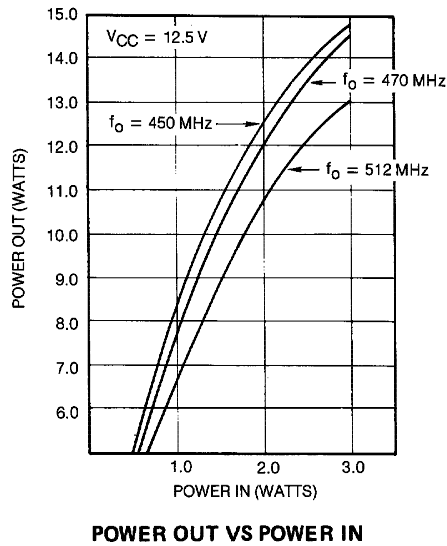

Figure 4. Power Gain & Efficiency vs Power Input

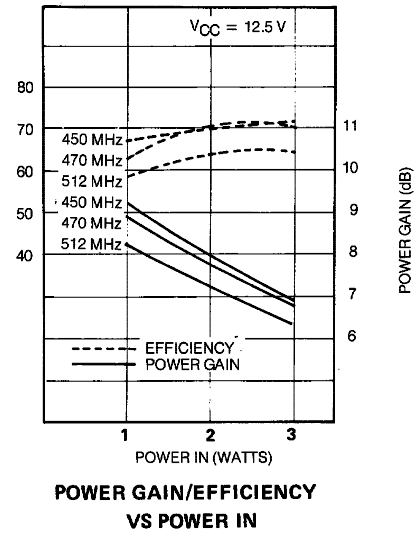
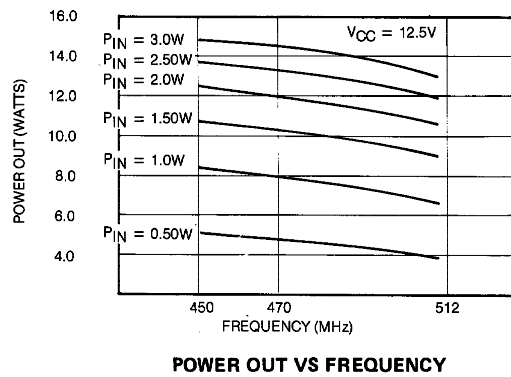
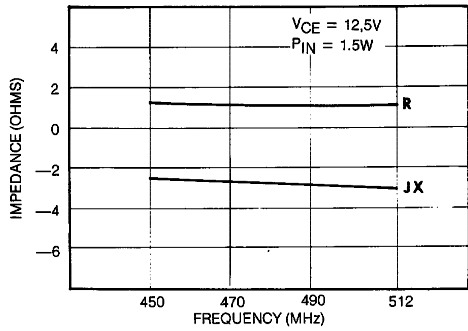

Figure 5. Power Output vs Frequency



IMPEDANCE DATA

Figure 6. Typical Input Impedance



SERIES SOURCE IMPEDANCE VS FREQUENCY

Figure 7. Typical Collector Load Impedance

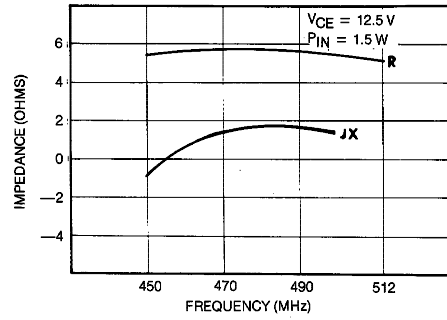

SERIES COLLECTOR LOAD IMPEDANCE VS FREQUENCY

Table 6. Impedance Data

FREQ.	Z _{IN} (Ω)	Z _{CL} (Ω)
470 MHz	1.5 - j 2.7	5.7 + j 1.5

Obsolete Product(s) - Obsolete Product(s)

TEST CIRCUIT

Figure 8. Test Circuit

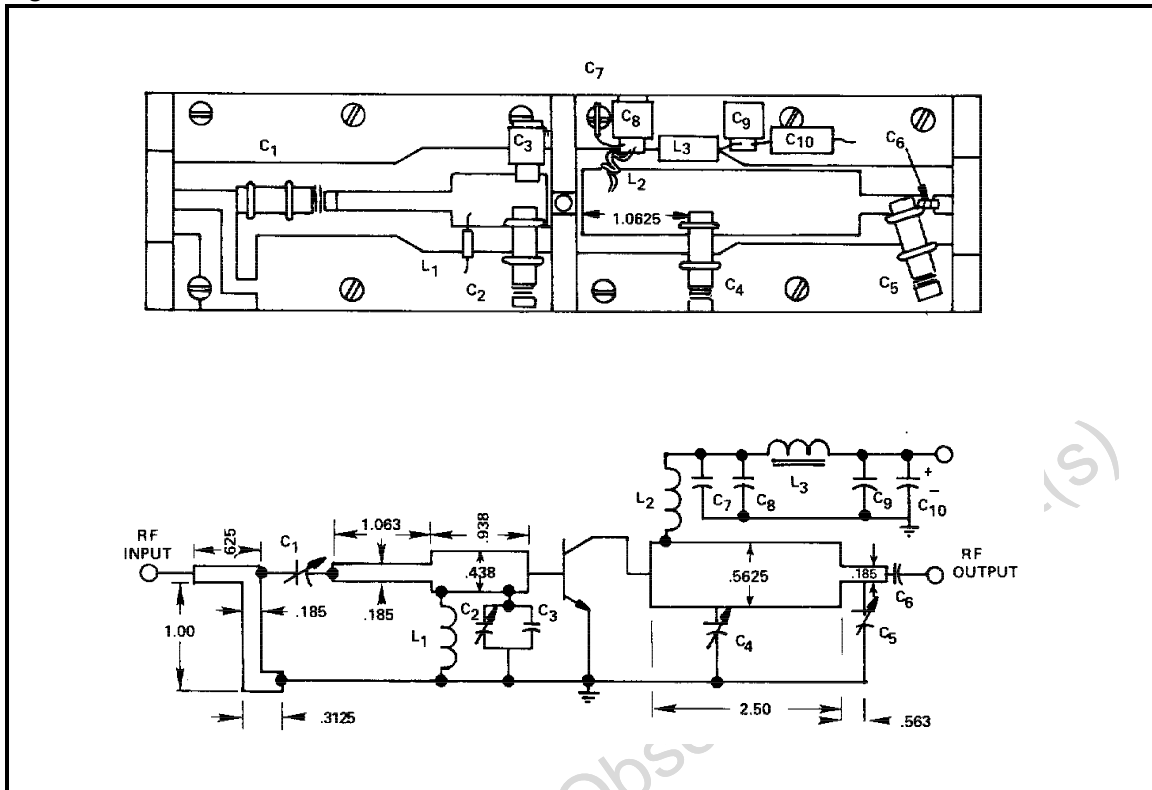

Table 7. Test Circuit

C1, C2:	0.8pF Voltronics
C3:	18pF Chip Capacitor
C4, C5:	AJ810
C6:	1000pF Chip Capacitor
C7:	0.01 μ F Disc Ceramic
C8, C9:	1000pF Unelco
C10:	10 μ F, 35V Electrolytic
L1:	0.47 μ H Molded Choke
L2:	2 Turns, #20 AWG, 1/8" I.D.
L3:	2 Turns in Ferroxcube VK200/19-4B
Board Material:	3M-K6098, 1/16" Thick

PACKAGE MECHANICAL

Table 8. M122 Mechanical Data

Symbol	millimeters			inches		
	Min	Typ	Max	Min	Typ	Max
A	25.65		26.80	1.010		1.055
B	5.59		5.84	0.220		0.230
C	6.86		7.24	0.270		0.285
D	0.08		0.18	0.003		0.007
E	2.97		3.48	0.117		0.137
F		14.53			0.572	
G		3.30			0.130	
H	6.22		6.48	0.245		0.255
I		16.26			0.640	
J	4.45		5.51	0.175		0.217
K	6.99		7.24	0.275		0.285

Figure 9. M122 Package Dimensions

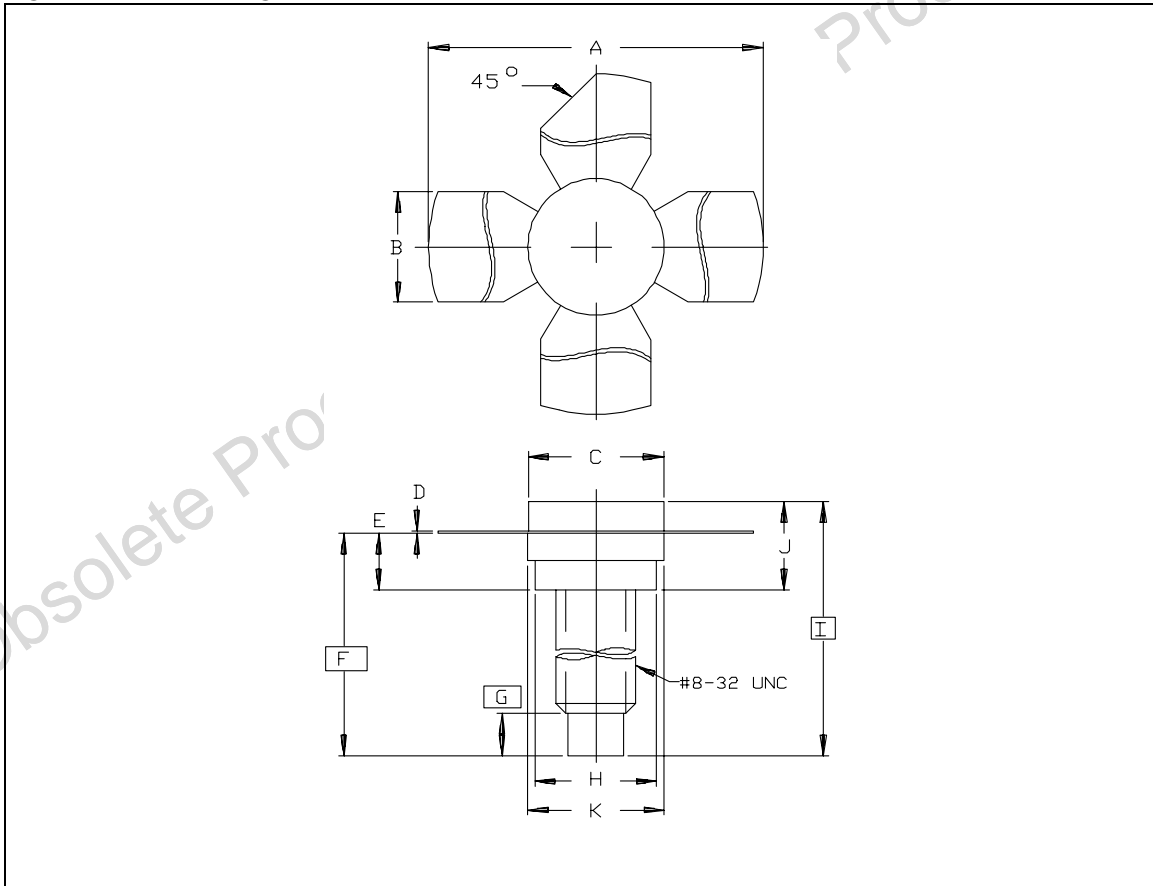

Note: Drawing is not to scale.

REVISION HISTORY**Table 9. Revision History**

Date	Revision	Description of Changes
November-1992	1	First Issue
28-May-2004	2	Stylesheet update. No content change.

Obsolete Product(s) - Obsolete Product(s)

Information furnished is believed to be accurate and reliable. However, STMicroelectronics assumes no responsibility for the consequences of use of such information nor for any infringement of patents or other rights of third parties which may result from its use. No license is granted by implication or otherwise under any patent or patent rights of STMicroelectronics. Specifications mentioned in this publication are subject to change without notice. This publication supersedes and replaces all information previously supplied. STMicroelectronics products are not authorized for use as critical components in life support devices or systems without express written approval of STMicroelectronics.

The ST logo is a registered trademark of STMicroelectronics.
All other names are the property of their respective owners

© 2004 STMicroelectronics - All rights reserved

STMicroelectronics GROUP OF COMPANIES

Australia - Belgium - Brazil - Canada - China - Czech Republic - Finland - France - Germany - Hong Kong - India - Israel - Italy - Japan -
Malaysia - Malta - Morocco - Singapore - Spain - Sweden - Switzerland - United Kingdom - United States

www.st.com