

NPN SILICON PLANAR RF TRANSISTOR

MPSH10

ISSUE 3 – NOVEMBER 94

FEATURES

- * High $f_T=650\text{MHz}$
- * Maximum capacitance 0.7pF
- * Low noise < 5dB at 500MHz

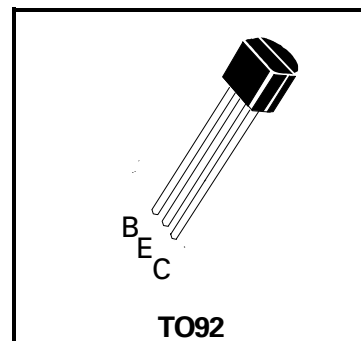

REFER TO MPSH10P FOR GRAPHS

ABSOLUTE MAXIMUM RATINGS.

PARAMETER	SYMBOL	VALUE	UNIT
Collector-Emitter Voltage	V_{CES}	30	V
Collector-Emitter Voltage	V_{CEO}	25	V
Emitter-Base Voltage	V_{EBO}	3	V
Continuous Collector Current	I_C	25	mA
Power Dissipation at $T_{amb}=25^\circ\text{C}$	P_{tot}	350	mW
Operating and Storage Temperature Range	$T_j; T_{stg}$	-55 to +150	$^\circ\text{C}$

ELECTRICAL CHARACTERISTICS (at $T_{amb} = 25^\circ\text{C}$)

PARAMETER	SYMBOL	MIN.	TYP.	MAX.	UNIT	CONDITIONS.
Collector-Base Breakdown Voltage	$V_{(BR)CBO}$	30			V	$I_C=100\mu\text{A}, I_E=0$
Collector-Emitter Breakdown Voltage	$V_{(BR)CEO}$	25			V	$I_C=1\text{mA}, I_B=0$
Emitter-Base Breakdown Voltage	$V_{(BR)EBO}$	3			V	$I_E=10\mu\text{A}, I_C=0$
Collector Cut-Off Current	I_{CBO}			100	nA	$V_{CB}=25\text{V}, I_E=0$
Emitter Cut-Off Current	I_{EBO}			100	nA	$V_{EB}=2\text{V}, I_C=0$
Collector-Emitter Saturation Voltage	$V_{CE(sat)}$			0.5	V	$I_C=4\text{mA}, I_B=0.4\text{mA}$
Base-Emitter Turn-On Voltage	$V_{BE(on)}$			0.95	V	$I_C=4\text{mA}, V_{CE}=10\text{V}$
Static Forward Current Transfer Ratio	h_{FE}	60				$I_C=4\text{mA}, V_{CE}=10\text{V}^*$
Transition Frequency	f_T	650			MHz	$I_C=4\text{mA}, V_{CE}=10\text{V}, f=100\text{MHz}$
Collector Base Capacitance	C_{cb}			0.7	pF	$V_{CB}=10\text{V}, I_E=0, f=1\text{MHz}$
Collector Base Time Constant	$r_b C_c$			9	ps	$I_C=4\text{mA}, V_{CE}=10\text{V}, f=31.8\text{MHz}$