



# SURFACE MOUNT NPN SILICON HIGH FREQUENCY TRANSISTOR

# NE686 SERIES

## FEATURES

- **HIGH GAIN BANDWIDTH PRODUCT:**  $f_t$  of 15 GHz
- **LOW VOLTAGE/LOW CURRENT OPERATION**
- **HIGH INSERTION POWER GAIN:**  
 $IS_{21eI}^2 = 12 \text{ dB @ } 2 \text{ V, } 7 \text{ mA, } 2 \text{ GHz}$   
 $IS_{21eI}^2 = 11 \text{ dB @ } 1 \text{ V, } 5 \text{ mA, } 2 \text{ GHz}$
- **LOW NOISE:** 1.5 dB AT 2.0 GHz
- **AVAILABLE IN SIX LOW COST PLASTIC SURFACE MOUNT PACKAGE STYLES**

## DESCRIPTION

NEC's NE686 series of NPN epitaxial silicon transistors are designed for low voltage/low current, amplifier and oscillator applications. NE686's high  $f_t$  make it an excellent choice for portable wireless applications up to 5 GHz. The NE686 die is available in six different low cost plastic surface mount package styles.



## ELECTRICAL CHARACTERISTICS (TA = 25°C)

SYMBOLS	PARAMETERS AND CONDITIONS	UNITS	PART NUMBER <sup>1</sup> EIAJ <sup>2</sup> REGISTERED NUMBER PACKAGE OUTLINE			NE68618 2SC5180 18			NE68619 2SC5181 19			NE68630 2SC5179 30			NE68633 2SC5177 33			NE68639/39R 2SC5178/78R 39/39R		
			MIN	TYP	MAX	MIN	TYP	MAX	MIN	TYP	MAX	MIN	TYP	MAX	MIN	TYP	MAX	MIN	TYP	MAX
$f_t$	Gain Bandwidth Product at $V_{CE} = 2 \text{ V, } I_c = 7 \text{ mA, } f = 2.0 \text{ GHz}$	GHz	12	15.5		10	13		7.5	9		10	13		10.5	13.5				
$f_t$	Gain Bandwidth Product at $V_{CE} = 1 \text{ V, } I_c = 5 \text{ mA, } f = 2.0 \text{ GHz}$	GHz	10	13		8.5	12		7	8.5		8.5	12		8.5	12				
NF <sub>MIN</sub>	Minimum Noise Figure at $V_{CE} = 2 \text{ V, } I_c = 3 \text{ mA, } f = 2.0 \text{ GHz}$	dB		1.5	2.0		1.5	2.0		1.5	2.0		1.5	2.0		1.5	2.0			
NF <sub>MIN</sub>	Minimum Noise Figure at $V_{CE} = 1 \text{ V, } I_c = 3 \text{ mA, } f = 2.0 \text{ GHz}$	dB		1.5	2.0		1.5	2.0		1.5	2.0		1.5	2.0		1.5	2.0			
$IS_{21eI}^2$	Insertion Power Gain at $V_{CE} = 2 \text{ V, } I_c = 7 \text{ mA, } f = 2.0 \text{ GHz}$	dB	10	12		8	10.5		7.5	9		7.5	9		9.5	11.5				
$IS_{21eI}^2$	Insertion Power Gain at $V_{CE} = 1 \text{ V, } I_c = 5 \text{ mA, } f = 2.0 \text{ GHz}$	dB	8.5	11		7	9		7	8.5		7	8.5		7.5	10.5				
h <sub>FE</sub>	Forward Current Gain <sup>3</sup> at $V_{CE} = 2 \text{ V, } I_c = 7 \text{ mA}$		70		140	70		140	70		140	70		140	70		140			
I <sub>CBO</sub>	Collector Cutoff Current at $V_{CB} = 5 \text{ V, } I_E = 0 \text{ mA}$	nA			100			100			100			100			100			
I <sub>EBO</sub>	Emitter Cutoff Current at $V_{EB} = 1 \text{ V, } I_c = 0 \text{ mA}$	nA			100			100			100			100			100			
CRE <sup>4</sup>	Feedback Capacitance at $V_{CB} = 2 \text{ V, } I_E = 0 \text{ mA, } f = 1 \text{ MHz}$	pF		0.3	0.5			0.4	0.6		0.4	0.6		0.5	0.6		0.3	0.5		
P <sub>T</sub>	Total Power Dissipation	mW			30			30			30			30			30			
R <sub>TH(J-A)</sub>	Thermal Resistance (Junction to Ambient)	°C/W			833			1250			833			625			625			
R <sub>TH(J-C)</sub>	Thermal Resistance(Junction to Case)	°C/W																		

- Notes: 1. Precaution: Devices are ESD sensitive. Use proper handling procedures.  
 2. Electronic Industrial Association of Japan.  
 3. Pulsed measurement,  $PW \leq 350 \mu\text{s}$ , duty cycle  $\leq 2\%$ .  
 4. The emitter terminal should be connected to the ground terminal of the 3 terminal capacitance bridge.

California Eastern Laboratories

# NE686 SERIES

## ABSOLUTE MAXIMUM RATINGS<sup>1</sup> (T<sub>A</sub> = 25°C)

SYMBOLS	PARAMETERS	UNITS	RATINGS
V <sub>CB0</sub>	Collector to Base Voltage	V	5
V <sub>CE0</sub>	Collector to Emitter Voltage	V	3
V <sub>EB0</sub>	Emitter to Base Voltage	V	2
I <sub>C</sub>	Collector Current	mA	10
T <sub>J</sub>	Operating Junction Temperature	°C	150
T <sub>STG</sub>	Storage Temperature	°C	-65 to +150

Notes:

1. Operation in excess of any one of these parameters may result in permanent damage.

## NE68618

### TYPICAL NOISE PARAMETERS (T<sub>A</sub> = 25°C)

FREQ. (MHz)	NF <sub>OPT</sub> (dB)	G <sub>A</sub> (dB)	Γ <sub>OPT</sub>		R <sub>n</sub> /50
			MAG	ANG	
V <sub>CE</sub> = 1.0 V, I <sub>C</sub> = 1.0 mA					
500	1.03	18.47	0.76	14	0.96
800	1.10	17.10	0.69	29	0.83
1000	1.15	14.81	0.66	34	0.78
1500	1.30	10.20	0.63	40	0.67
2000	1.52	7.97	0.58	50	0.58
2500	1.74	6.65	0.51	61	0.53
V <sub>CE</sub> = 1.0 V, I <sub>C</sub> = 3.0 mA					
500	1.30	21.08	0.61	13	0.56
800	1.33	17.51	0.58	23	0.53
1000	1.36	15.75	0.55	28	0.52
1500	1.50	12.35	0.50	37	0.50
2000	1.67	10.03	0.46	45	0.48
2500	1.83	8.47	0.41	54	0.44
3000	1.98	7.30	0.36	64	0.33
V <sub>CE</sub> = 2.0 V, I <sub>C</sub> = 3.0 mA					
500	1.30	21.96	0.61	13	0.66
800	1.33	18.38	0.58	23	0.58
1000	1.36	16.61	0.55	28	0.57
1500	1.50	13.20	0.50	37	0.55
2000	1.67	10.81	0.46	45	0.50
2500	1.83	9.22	0.41	54	0.47
3000	1.98	8.00	0.36	64	0.38
V <sub>CE</sub> = 2.0 V, I <sub>C</sub> = 10.0 mA					
500	2.15	23.2	0.39	14	0.58
800	2.17	19.21	0.36	20	0.56
1000	2.20	17.52	0.32	27	0.55
1500	2.28	14.18	0.27	36	0.51
2000	2.42	11.81	0.24	45	0.48
2500	2.55	10.09	0.21	51	0.43
3000	2.70	8.78	0.17	61	0.29

## NE68619

### TYPICAL NOISE PARAMETERS (T<sub>A</sub> = 25°C)

FREQ. (MHz)	NF <sub>OPT</sub> (dB)	G <sub>A</sub> (dB)	Γ <sub>OPT</sub>		R <sub>n</sub> /50
			MAG	ANG	
V <sub>CE</sub> = 0.5 V, I <sub>C</sub> = 0.5 mA					
500	0.96	15.00	0.76	16	1.20
800	1.03	12.50	0.76	30	1.13
1000	1.10	11.94	0.72	40	1.09
1500	1.42	6.69	0.67	48	1.10
V <sub>CE</sub> = 1.0 V, I <sub>C</sub> = 1.0 mA					
500	0.91	17.59	0.73	14	1.09
800	1.00	15.38	0.69	28	0.82
1000	1.08	14.50	0.66	38	0.80
1500	1.35	9.78	0.63	46	0.78
2000	1.60	7.41	0.59	56	0.75
2500	1.80	6.15	0.53	70	0.68
V <sub>CE</sub> = 1.0 V, I <sub>C</sub> = 3.0 mA					
500	1.35	20.29	0.63	15	0.59
800	1.38	16.88	0.60	28	0.55
1000	1.43	15.44	0.56	37	0.52
1500	1.55	11.50	0.53	43	0.51
2000	1.67	9.28	0.48	51	0.50
2500	1.78	7.70	0.44	62	0.47
3000	1.83	6.52	0.30	71	0.38
V <sub>CE</sub> = 1.0 V, I <sub>C</sub> = 5.0 mA					
500	1.68	21.17	0.50	14	0.55
800	1.70	17.59	0.48	28	0.53
1000	1.74	15.74	0.46	33	0.52
1500	1.83	12.25	0.42	41	0.51
2000	1.91	10.00	0.38	53	0.49
2500	2.00	8.49	0.33	65	0.39
3000	2.09	7.30	0.28	77	0.35
V <sub>CE</sub> = 2.0 V, I <sub>C</sub> = 3.0 mA					
500	1.35	21.12	0.63	15	0.68
800	1.38	17.80	0.60	28	0.62
1000	1.43	16.34	0.56	37	0.60
1500	1.55	12.36	0.53	43	0.58
2000	1.67	10.00	0.48	51	0.56
2500	1.78	8.48	0.44	62	0.50
3000	1.83	7.24	0.40	71	0.36

**TYPICAL PERFORMANCE CURVES** ( $T_A = 25^\circ$ )

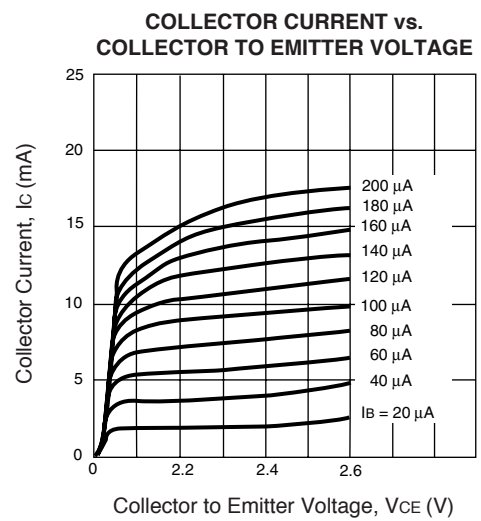
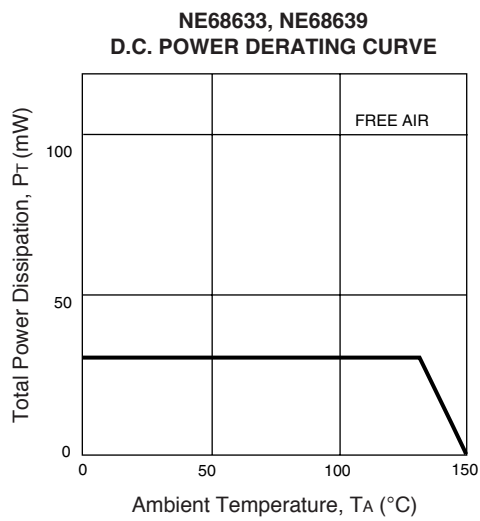
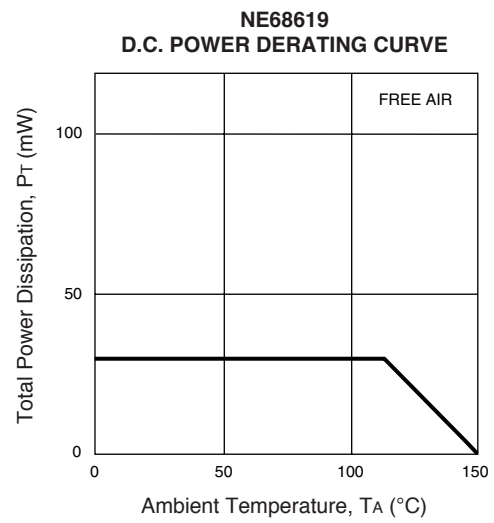
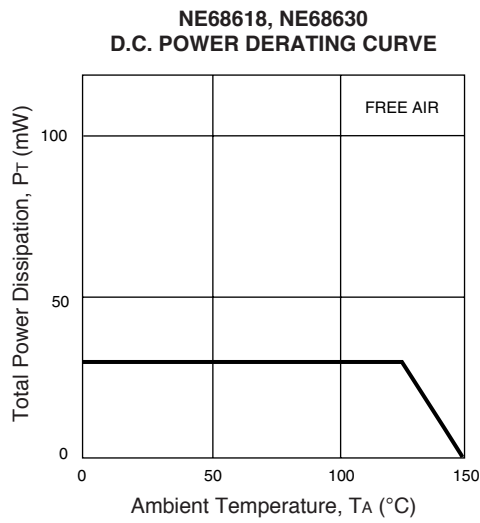

TYPICAL PERFORMANCE CURVES (TA = 25°C)

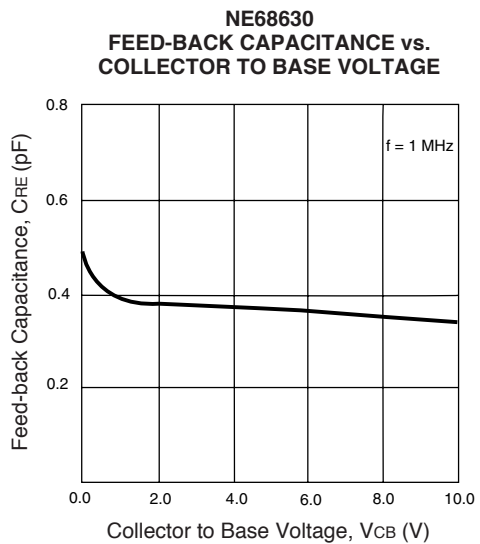
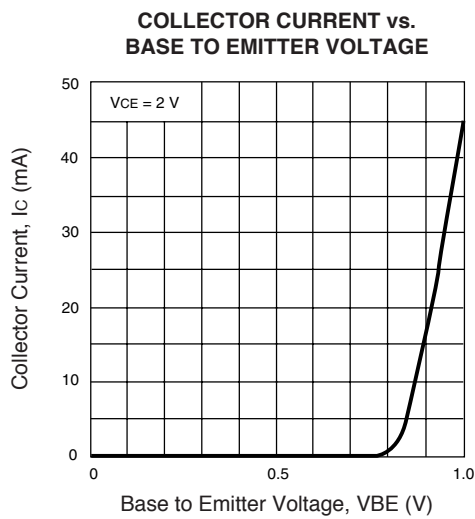
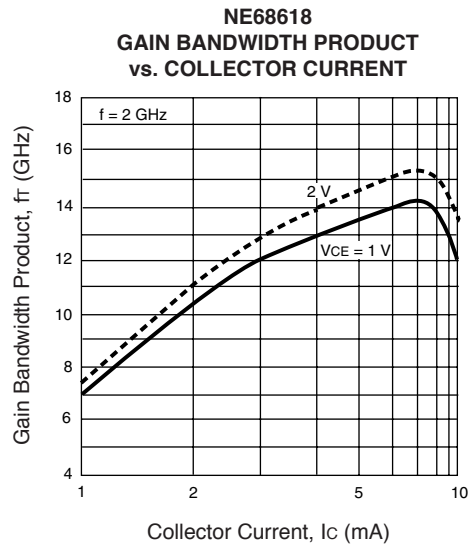
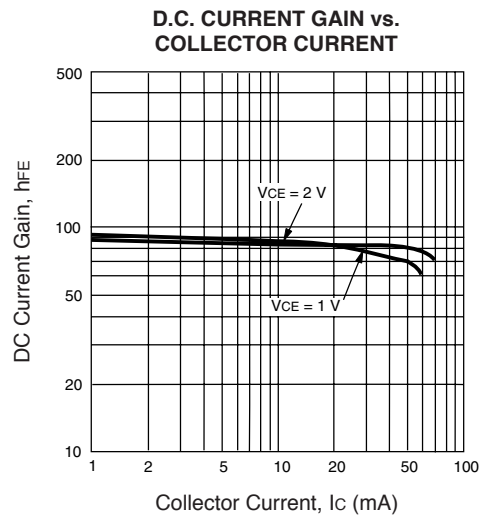
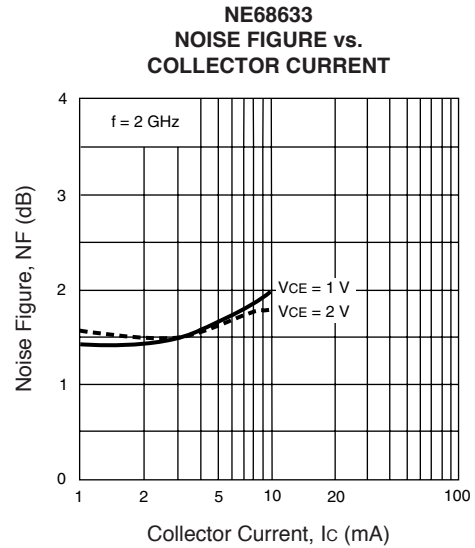
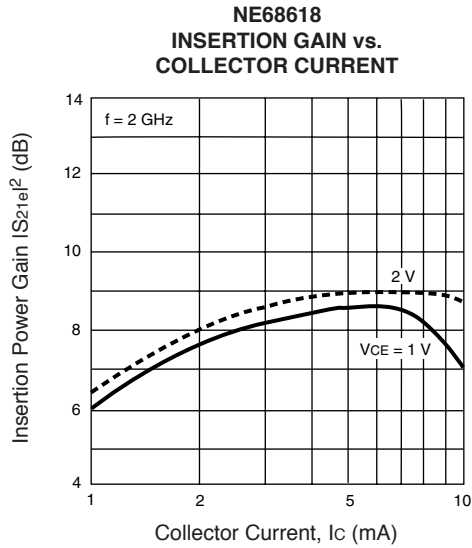

TYPICAL SCATTERING PARAMETERS (TA = 25°C)

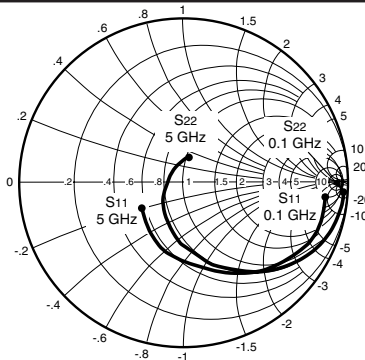

Coordinates in Ohms  
Frequency in GHz  
(VCE = 1 V, IC = 3 mA)

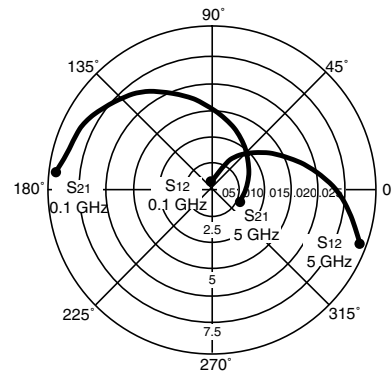

NE68618

VCE = 0.5 V, IC = 0.5 mA

FREQUENCY	S11		S21		S12		S22		K	MAG <sup>1</sup>
GHz	MAG	ANG	MAG	ANG	MAG	ANG	MAG	ANG		(dB)
0.1	0.981	-5.400	1.742	170.900	0.018	85.100	0.998	-4.500	0.088	19.858
0.4	0.965	-19.400	1.717	156.600	0.069	72.900	0.988	-17.400	0.128	13.959
0.8	0.910	-38.900	1.667	134.100	0.130	56.400	0.953	-33.800	0.247	11.080
1.0	0.873	-47.700	1.620	123.700	0.156	48.600	0.930	-41.500	0.310	10.164
1.5	0.775	-70.200	1.506	98.600	0.208	30.500	0.863	-59.000	0.455	8.598
2.0	0.675	-90.800	1.385	76.400	0.241	15.000	0.795	-74.000	0.595	7.594
2.5	0.584	-111.200	1.289	56.200	0.261	1.800	0.741	-86.800	0.714	6.936
3.0	0.505	-130.500	1.215	38.700	0.273	-9.500	0.694	-98.500	0.820	6.484
4.0	0.363	-175.500	1.118	6.100	0.289	-29.700	0.599	-120.800	1.013	5.181
5.0	0.298	122.200	1.049	-26.800	0.289	-47.800	0.492	-151.700	1.187	2.982

VCE = 1.0 V, IC = 1.0 mA

0.1	0.951	-6.200	3.324	171.000	0.015	82.800	0.995	-4.900	0.119	23.456
0.4	0.941	-21.900	3.232	154.800	0.057	71.800	0.976	-19.000	0.147	17.536
0.8	0.854	-43.300	3.027	131.200	0.105	55.200	0.919	-36.500	0.277	14.598
1.0	0.799	-53.000	2.879	120.700	0.125	47.700	0.884	-44.400	0.341	13.623
1.5	0.669	-75.800	2.529	95.900	0.161	31.200	0.793	-61.500	0.507	11.961
2.0	0.554	-95.800	2.211	74.800	0.184	18.500	0.715	-75.600	0.656	10.798
2.5	0.456	-114.500	1.969	55.800	0.199	8.000	0.657	-87.300	0.793	9.954
3.0	0.378	-132.100	1.781	39.300	0.211	-0.500	0.611	-97.900	0.907	9.264
4.0	0.247	-176.200	1.543	8.700	0.238	-15.500	0.520	-119.200	1.075	6.442
5.0	0.207	114.600	1.397	-22.400	0.269	-31.300	0.411	-151.100	1.165	4.693

VCE = 1.0 V, IC = 3.0 mA

0.1	0.888	-9.000	8.309	169.500	0.015	86.700	0.981	-7.200	0.058	27.435
0.4	0.806	-34.400	7.521	143.100	0.053	66.400	0.905	-27.100	0.266	21.520
0.8	0.619	-61.800	6.033	114.400	0.088	50.300	0.758	-46.800	0.486	18.361
1.0	0.537	-72.800	5.360	103.200	0.101	44.600	0.695	-54.100	0.580	17.248
1.5	0.377	-95.200	4.085	79.700	0.126	34.100	0.582	-67.900	0.782	15.108
2.0	0.272	-113.800	3.257	61.200	0.148	26.500	0.516	-78.500	0.921	13.426
2.5	0.201	-131.800	2.729	44.700	0.168	19.300	0.478	-87.400	1.015	11.363
3.0	0.149	-147.600	2.359	30.200	0.190	12.500	0.453	-96.200	1.072	9.303
4.0	0.092	146.900	1.921	3.400	0.240	-2.500	0.387	-116.200	1.114	6.980
5.0	0.175	74.000	1.669	-24.300	0.292	-20.500	0.284	-150.600	1.116	5.501

VCE = 2.0 V, IC = 3.0 mA

0.1	0.888	-8.100	8.454	169.600	0.013	81.500	0.986	-6.600	0.146	28.131
0.4	0.819	-31.700	7.701	144.300	0.047	68.200	0.918	-25.000	0.263	22.144
0.8	0.638	-57.400	6.259	116.100	0.080	52.500	0.785	-43.400	0.483	18.934
1.0	0.555	-67.400	5.586	105.000	0.092	46.900	0.727	-50.500	0.576	17.833
1.5	0.389	-87.700	4.289	81.500	0.116	36.500	0.621	-63.800	0.775	15.679
2.0	0.282	-103.500	3.425	63.000	0.138	28.700	0.558	-74.100	0.909	13.948
2.5	0.203	-118.000	2.868	46.600	0.157	21.600	0.524	-82.800	0.999	12.617
3.0	0.145	-127.900	2.472	32.300	0.178	14.700	0.503	-91.300	1.056	9.982
4.0	0.056	-178.900	2.004	5.900	0.225	-0.200	0.446	-109.700	1.101	7.565
5.0	0.126	66.600	1.747	-21.100	0.278	-17.500	0.346	-138.700	1.098	6.072

Note:

1. Gain Calculation:

$$MAG = \frac{|S_{21}|}{|S_{12}|} (K \pm \sqrt{K^2 - 1})$$

When  $K \leq 1$ , MAG is undefined and MSG values are used.  $MSG = \frac{|S_{21}|}{|S_{12}|}$ ,  $K = \frac{1 + |\Delta|^2 - |S_{11}|^2 - |S_{22}|^2}{2 |S_{12}| |S_{21}|}$ ,  $\Delta = S_{11} S_{22} - S_{21} S_{12}$

MAG = Maximum Available Gain

MSG = Maximum Stable Gain

# NE686 SERIES

## TYPICAL SCATTERING PARAMETERS (TA = 25°C)

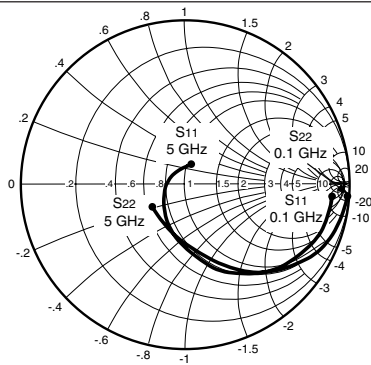

Coordinates in Ohms  
Frequency in GHz  
(VCE = 1 V, IC = 3 mA)

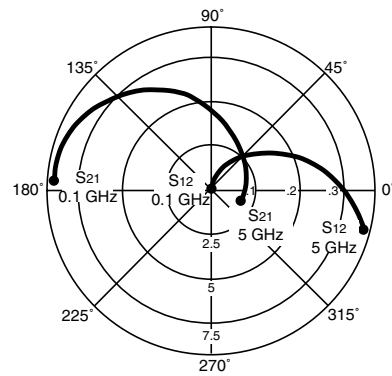

### NE68619

VCE = 0.5 V, IC = 0.5 mA

FREQUENCY GHz	S11		S21		S12		S22		K	MAG <sup>1</sup> (dB)
	MAG	ANG	MAG	ANG	MAG	ANG	MAG	ANG		
0.1	0.978	-5.400	1.736	170.700	0.020	84.800	0.997	-4.700	0.096	19.385
0.4	0.959	-21.100	1.711	154.500	0.080	71.800	0.984	-18.400	0.147	13.302
0.8	0.897	-41.100	1.617	131.200	0.148	54.700	0.936	-34.900	0.289	10.384
1.0	0.861	-50.000	1.562	120.500	0.176	47.000	0.907	-42.000	0.363	9.482
1.5	0.758	-72.300	1.414	96.300	0.227	30.200	0.827	-56.800	0.526	7.944
2.0	0.670	-92.200	1.302	75.400	0.259	16.800	0.749	-68.400	0.676	7.013
2.5	0.591	-110.700	1.211	56.800	0.281	5.400	0.685	-78.100	0.809	6.344
3.0	0.517	-129.300	1.163	40.000	0.298	-4.600	0.619	-88.300	0.919	5.914
4.0	0.372	-167.900	1.088	7.900	0.321	-23.200	0.488	-113.800	1.126	3.145
5.0	0.251	140.900	1.015	-22.800	0.320	-39.200	0.398	-152.600	1.313	1.663

VCE = 1.0 V, IC = 1.0 mA

0.1	0.961	-6.300	3.302	171.100	0.018	82.900	0.994	-5.400	0.109	22.635
0.4	0.930	-24.200	3.199	152.900	0.068	71.000	0.970	-20.700	0.146	16.725
0.8	0.836	-46.000	2.916	129.000	0.123	53.900	0.899	-38.500	0.294	13.749
1.0	0.784	-55.600	2.756	118.400	0.144	46.900	0.860	-45.900	0.362	12.819
1.5	0.660	-78.000	2.370	94.800	0.182	31.900	0.761	-60.600	0.532	11.147
2.0	0.562	-97.200	2.065	75.200	0.207	21.100	0.677	-71.400	0.681	9.989
2.5	0.480	-115.000	1.847	57.500	0.226	12.500	0.609	-80.100	0.814	9.124
3.0	0.408	-131.900	1.699	41.600	0.244	5.100	0.547	-89.400	0.920	8.428
4.0	0.280	-169.700	1.504	11.500	0.284	-9.200	0.431	-114.200	1.058	5.763
5.0	0.180	131.100	1.356	-18.200	0.320	-24.300	0.360	-153.900	1.126	4.110

VCE = 1.0 V, IC = 3.0 mA

0.1	0.892	-9.200	8.262	169.100	0.016	82.600	0.977	-8.000	0.118	27.130
0.4	0.787	-37.400	7.340	140.500	0.061	65.500	0.886	-29.400	0.281	20.804
0.8	0.588	-64.400	5.668	111.800	0.100	50.400	0.721	-48.500	0.523	17.534
1.0	0.508	-74.400	4.989	100.900	0.114	45.500	0.658	-54.700	0.622	16.411
1.5	0.364	-94.500	3.743	78.900	0.142	37.000	0.548	-64.600	0.819	14.209
2.0	0.282	-110.800	2.989	61.800	0.168	30.900	0.483	-70.900	0.943	12.502
2.5	0.223	-124.100	2.515	46.400	0.197	24.800	0.439	-75.600	1.020	10.186
3.0	0.179	-140.000	2.202	32.500	0.226	18.500	0.400	-82.000	1.062	8.366
4.0	0.104	168.400	1.825	6.200	0.293	3.400	0.309	-103.900	1.086	6.160
5.0	0.127	70.800	1.587	-20.100	0.355	-14.700	0.242	-147.500	1.081	4.769

VCE = 2.0 V, IC = 3.0 mA

0.1	0.904	-9.100	8.282	169.400	0.015	80.300	0.982	-7.500	0.146	27.420
0.4	0.802	-34.800	7.456	142.400	0.056	66.800	0.902	-27.800	0.266	21.243
0.8	0.619	-60.300	5.880	114.400	0.094	51.800	0.748	-46.500	0.498	17.962
1.0	0.542	-70.200	5.215	103.600	0.107	46.700	0.686	-52.800	0.593	16.879
1.5	0.403	-89.400	3.951	81.500	0.134	37.900	0.576	-63.000	0.786	14.696
2.0	0.315	-105.000	3.172	64.500	0.159	31.700	0.509	-69.600	0.912	12.999
2.5	0.260	-117.100	2.670	49.100	0.185	25.800	0.464	-74.500	0.995	11.593
3.0	0.216	-130.900	2.337	35.400	0.213	19.500	0.424	-80.800	1.040	9.182
4.0	0.134	-168.900	1.938	9.200	0.276	4.900	0.334	-102.000	1.071	6.832
5.0	0.094	96.000	1.691	-17.000	0.337	-12.900	0.265	-143.300	1.070	5.392

See note on previous page.

TYPICAL SCATTERING PARAMETERS (TA = 25°C)

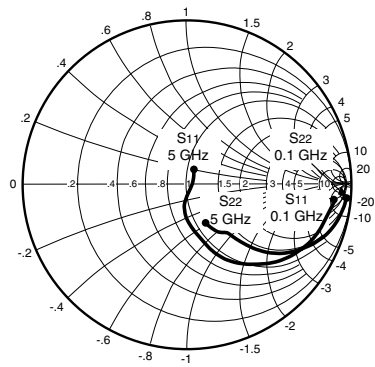

Coordinates in Ohms  
Frequency in GHz  
(VCE = 1 V, IC = 3 mA)

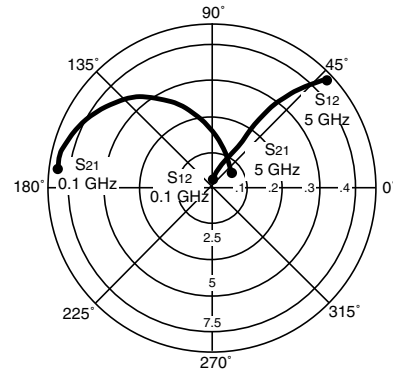

NE68630

VCE = 1.0 V, IC = 1.0 mA

FREQUENCY GHz	S11		S21		S12		S22		K	MAG <sup>1</sup> (dB)
	MAG	ANG	MAG	ANG	MAG	ANG	MAG	ANG		
0.1	0.958	-5.400	3.367	172.000	0.025	84.700	0.991	-5.000	0.099	21.293
0.4	0.910	-22.800	3.220	153.400	0.092	73.800	0.949	-18.900	0.194	15.441
0.8	0.785	-42.300	2.873	131.200	0.162	61.200	0.843	-34.100	0.366	12.488
1.0	0.712	-50.100	2.675	121.800	0.189	56.600	0.788	-40.100	0.451	11.509
1.5	0.557	-67.000	2.254	102.100	0.234	48.200	0.665	-51.500	0.636	9.837
2.0	0.438	-80.000	1.929	87.000	0.264	43.800	0.577	-58.900	0.785	8.637
2.5	0.340	-90.100	1.708	74.600	0.288	41.800	0.516	-64.200	0.903	7.731
3.0	0.262	-98.500	1.552	64.300	0.310	40.900	0.475	-68.800	0.985	6.995
4.0	0.137	-117.500	1.336	47.900	0.364	40.300	0.407	-76.700	1.073	3.998
5.0	0.081	159.300	1.247	33.800	0.432	37.900	0.318	-89.800	1.072	2.961

VCE = 1.0 V, IC = 3.0 mA

0.1	0.887	-10.600	8.217	167.700	0.024	81.700	0.969	-8.500	0.154	25.345
0.4	0.718	-40.600	6.754	137.100	0.078	66.700	0.815	-28.700	0.386	19.375
0.8	0.480	-64.500	4.780	111.800	0.121	58.200	0.612	-41.300	0.676	15.966
1.0	0.391	-72.000	4.086	103.500	0.138	56.800	0.546	-44.200	0.785	14.714
1.5	0.251	-85.900	2.992	87.800	0.176	55.700	0.447	-47.600	0.962	12.304
2.0	0.165	-94.200	2.373	76.600	0.214	55.000	0.399	-49.000	1.054	9.032
2.5	0.098	-96.600	1.993	67.300	0.252	54.100	0.375	-50.200	1.100	7.058
3.0	0.051	-88.500	1.745	59.200	0.288	52.600	0.363	-52.200	1.118	5.731
4.0	0.042	17.300	1.428	46.400	0.362	48.400	0.337	-56.900	1.124	3.817
5.0	0.099	60.800	1.280	35.400	0.433	43.400	0.264	-63.300	1.104	2.741

VCE = 1.0 V, IC = 5.0 mA

0.1	0.826	-13.600	11.659	165.100	0.023	80.000	0.949	-11.200	0.194	27.049
0.4	0.613	-46.800	8.787	130.400	0.073	66.900	0.736	-35.200	0.471	20.805
0.8	0.379	-69.300	5.730	105.800	0.116	62.200	0.520	-47.300	0.753	16.937
1.0	0.303	-75.700	4.805	98.200	0.134	61.600	0.459	-49.900	0.842	15.546
1.5	0.190	-86.800	3.434	83.800	0.181	60.900	0.375	-52.900	0.959	12.781
2.0	0.123	-93.300	2.693	73.300	0.227	59.400	0.338	-54.600	1.012	10.084
2.5	0.074	-93.100	2.251	64.500	0.273	57.300	0.321	-56.500	1.032	8.058
3.0	0.043	-80.100	1.958	56.800	0.316	54.700	0.315	-59.400	1.040	6.692
4.0	0.029	17.700	1.595	44.000	0.401	48.600	0.294	-67.500	1.040	4.770
5.0	0.088	80.400	1.427	32.300	0.480	41.700	0.218	-82.000	1.028	3.714

VCE = 2.0 V, IC = 3.0 mA

0.1	0.898	-9.500	8.250	168.600	0.022	83.000	0.975	-7.900	0.132	25.740
0.4	0.749	-35.900	6.999	139.900	0.075	69.200	0.841	-27.500	0.357	19.700
0.8	0.525	-57.500	5.127	114.800	0.121	60.800	0.645	-41.300	0.625	16.271
1.0	0.438	-64.300	4.423	106.300	0.138	59.000	0.577	-44.900	0.727	15.058
1.5	0.297	-75.100	3.271	90.100	0.178	57.400	0.470	-49.400	0.896	12.643
2.0	0.209	-80.300	2.599	78.700	0.217	56.200	0.416	-51.600	0.988	10.783
2.5	0.148	-81.000	2.187	69.000	0.256	55.000	0.389	-53.100	1.033	8.201
3.0	0.107	-73.500	1.909	60.900	0.294	53.300	0.375	-55.300	1.056	6.682
4.0	0.064	-42.400	1.558	47.800	0.370	49.000	0.349	-60.600	1.068	4.653
5.0	0.049	43.000	1.397	36.400	0.444	43.600	0.276	-69.000	1.057	3.522

See note on next page

# NE686 SERIES

## TYPICAL SCATTERING PARAMETERS (TA = 25°C)

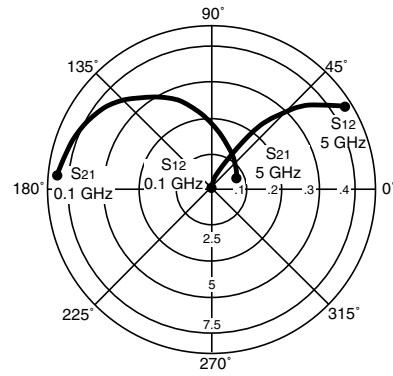
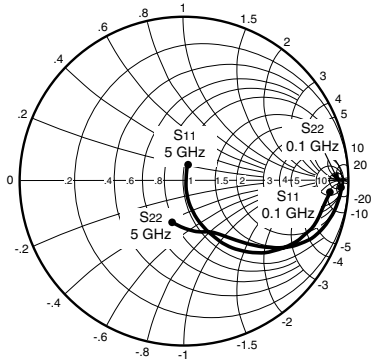

Coordinates in Ohms  
Frequency in GHz  
(VCE = 1 V, Ic = 3 mA)

### NE68633

VCE = 1.0 V, Ic = 1.0 mA

0.1	0.951	-4.800	3.286	170.200	0.022	85.000	0.992	-4.400	0.139	21.742
0.4	0.916	-20.800	3.203	154.600	0.079	74.800	0.958	-17.000	0.196	16.079
0.8	0.793	-39.700	2.914	131.500	0.142	62.200	0.862	-31.200	0.386	13.122
1.0	0.723	-47.500	2.730	121.800	0.167	57.400	0.811	-37.000	0.471	12.134
1.5	0.560	-65.000	2.338	100.900	0.212	48.200	0.685	-48.700	0.663	10.425
2.0	0.415	-78.500	2.017	83.600	0.242	42.800	0.588	-57.400	0.832	9.209
2.5	0.304	-92.200	1.786	69.500	0.266	39.500	0.518	-65.000	0.947	8.270
3.0	0.222	-104.600	1.607	57.600	0.290	37.600	0.468	-72.500	1.025	6.458
4.0	0.100	-144.900	1.389	38.200	0.347	34.900	0.402	-87.600	1.079	4.313
5.0	0.095	123.200	1.260	21.000	0.422	30.400	0.349	-107.900	1.057	3.286

### VCE = 1.0 V, Ic = 3.0 mA

0.1	0.889	-8.500	8.189	167.000	0.021	85.000	0.973	-7.600	0.147	25.910
0.4	0.750	-33.500	7.038	139.600	0.070	70.100	0.847	-26.100	0.380	20.024
0.8	0.519	-53.800	5.176	112.800	0.114	61.600	0.658	-39.300	0.661	16.571
1.0	0.432	-59.900	4.470	103.500	0.133	59.500	0.592	-42.900	0.760	15.265
1.5	0.285	-69.900	3.309	86.100	0.175	56.700	0.481	-48.700	0.920	12.767
2.0	0.186	-74.600	2.641	72.600	0.217	54.200	0.419	-53.200	1.002	10.604
2.5	0.113	-78.500	2.218	61.600	0.259	51.400	0.379	-58.600	1.038	8.139
3.0	0.065	-74.200	1.934	51.900	0.301	48.100	0.353	-65.200	1.051	6.692
4.0	0.019	36.600	1.606	35.700	0.384	40.600	0.311	-81.600	1.044	4.938
5.0	0.099	72.600	1.426	20.500	0.467	31.800	0.262	-104.700	1.023	3.921

### VCE = 1.0 V, Ic = 5.0 mA

0.1	0.826	-11.900	11.534	163.800	0.021	84.800	0.955	-9.700	0.176	27.398
0.4	0.623	-40.600	8.878	130.600	0.064	69.300	0.761	-30.000	0.507	21.421
0.8	0.385	-57.600	5.834	104.700	0.105	64.100	0.563	-39.700	0.796	17.448
1.0	0.311	-61.900	4.901	96.300	0.123	63.100	0.507	-41.700	0.877	16.004
1.5	0.193	-66.600	3.501	81.000	0.169	60.900	0.424	-45.400	0.986	13.163
2.0	0.121	-64.700	2.751	69.000	0.216	58.000	0.379	-49.200	1.029	9.999
2.5	0.069	-57.300	2.294	58.900	0.263	54.300	0.349	-54.800	1.043	8.138
3.0	0.043	-32.000	1.986	49.900	0.307	50.300	0.329	-61.900	1.049	6.761
4.0	0.047	46.100	1.640	34.400	0.394	41.600	0.292	-79.400	1.034	5.066
5.0	0.120	65.700	1.452	19.800	0.477	32.000	0.243	-103.700	1.016	4.066

### VCE = 2.0 V, Ic = 3.0 mA

0.1	0.894	-7.900	8.161	167.300	0.018	84.000	0.978	-7.000	0.161	26.565
0.4	0.766	-31.100	7.109	141.000	0.066	71.500	0.862	-24.300	0.372	20.323
0.8	0.544	-50.100	5.308	114.600	0.109	62.900	0.682	-37.000	0.650	16.875
1.0	0.460	-55.400	4.601	105.300	0.127	60.800	0.618	-40.500	0.749	15.590
1.5	0.311	-63.800	3.423	88.000	0.168	57.800	0.509	-46.200	0.908	13.091
2.0	0.217	-66.800	2.731	74.700	0.209	55.500	0.448	-50.500	0.990	11.162
2.5	0.147	-67.800	2.297	63.800	0.249	52.600	0.409	-55.600	1.028	8.616
3.0	0.102	-63.900	2.002	54.100	0.290	49.400	0.384	-61.800	1.042	7.129
4.0	0.042	-34.200	1.655	38.200	0.370	42.400	0.345	-76.800	1.038	5.306
5.0	0.068	52.700	1.475	23.200	0.453	34.000	0.296	-97.100	1.018	4.311

Note:

1. Gain Calculation:

$$MAG = \frac{|S_{21}|}{|S_{12}|} (K \pm \sqrt{K^2 - 1})$$

When  $K \leq 1$ , MAG is undefined and MSG values are used.  $MSG = \frac{|S_{21}|}{|S_{12}|}$ ,  $K = \frac{1 + |\Delta|^2 - |S_{11}|^2 - |S_{22}|^2}{2 |S_{12}| |S_{21}|}$ ,  $\Delta = S_{11} S_{22} - S_{21} S_{12}$

MAG = Maximum Available Gain      MSG = Maximum Stable Gain



OUTLINE DIMENSIONS (Units in mm)

PACKAGE OUTLINE 18  
(SOT-343)

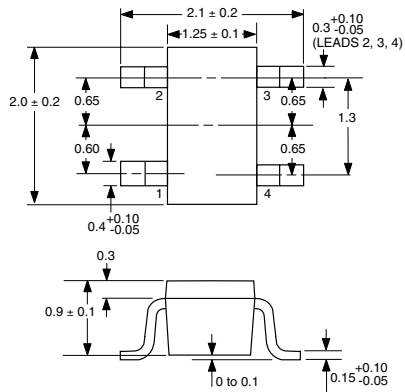

LEAD CONNECTIONS

1. Collector
2. Emitter
3. Base
4. Emitter

OUTLINE 18  
RECOMMENDED P.C.B. LAYOUT

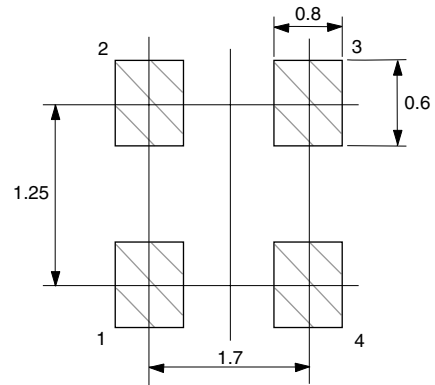

PACKAGE OUTLINE 19

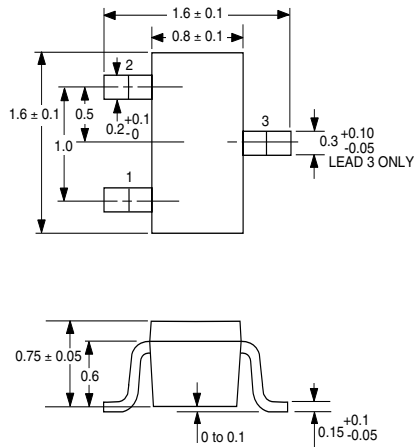

LEAD CONNECTIONS

1. Emitter
2. Base
3. Collector

OUTLINE 19  
RECOMMENDED P.C.B. LAYOUT

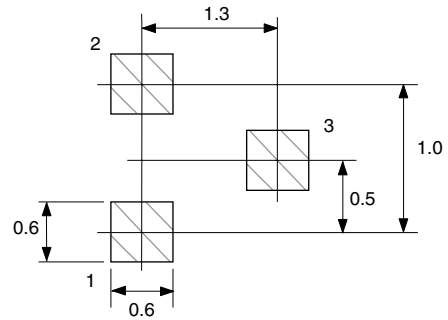

PACKAGE OUTLINE 30  
(SOT-323)

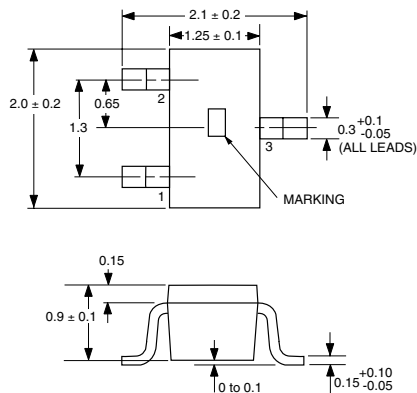

LEAD CONNECTIONS

1. Emitter
2. Base
3. Collector

OUTLINE 30  
RECOMMENDED P.C.B. LAYOUT

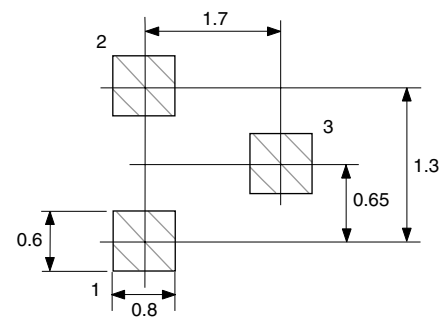

**OUTLINE DIMENSIONS** (Units in mm)

**PACKAGE OUTLINE 33**  
(SOT-23)

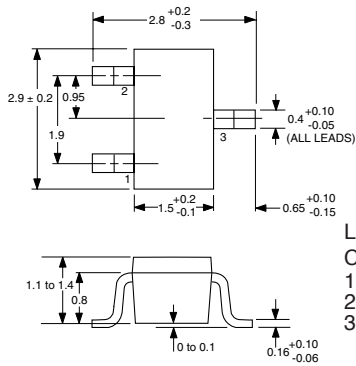

**LEAD CONNECTIONS**  
1. Emitter  
2. Base  
3. Collector

**OUTLINE 33**  
**RECOMMENDED P.C.B. LAYOUT**

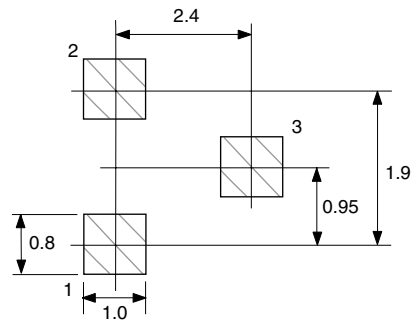

**PACKAGE OUTLINE 39**  
(SOT-143)

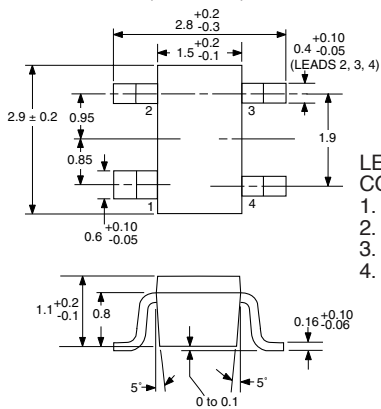

**LEAD CONNECTIONS**  
1. Collector  
2. Emitter  
3. Base  
4. Emitter

**OUTLINE 39**  
**RECOMMENDED P.C.B. LAYOUT**

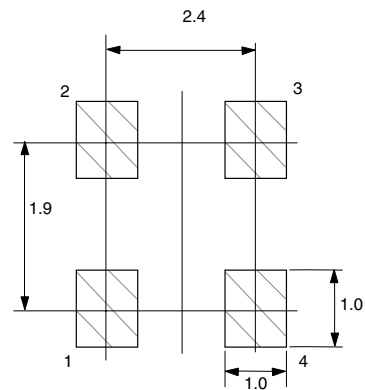

**PACKAGE OUTLINE 39R**  
(SOT-143)

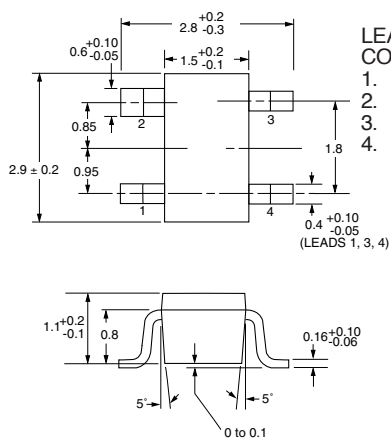

**LEAD CONNECTIONS**  
1. Emitter  
2. Collector  
3. Emitter  
4. Base

**OUTLINE 39R**  
**RECOMMENDED P.C.B. LAYOUT**

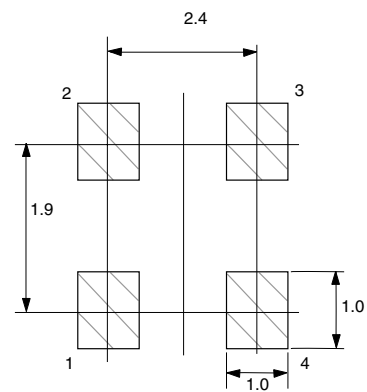

**ORDERING INFORMATION**

PART NUMBER	QUANTITY	PACKAGING
NE68618-T1-A	3000	Tape & Reel
NE68619-T1-A	3000	Tape & Reel
NE68630-T1	3000	Tape & Reel
NE68633-T1	3000	Tape & Reel
NE68639-T1	3000	Tape & Reel
NE68639R-T1	3000	Tape & Reel

## Note:

1. Lead material: Cu  
Lead plating: PbSn

## Life Support Applications

These NEC products are not intended for use in life support devices, appliances, or systems where the malfunction of these products can reasonably be expected to result in personal injury. The customers of CEL using or selling these products for use in such applications do so at their own risk and agree to fully indemnify CEL for all damages resulting from such improper use or sale.

EXCLUSIVE NORTH AMERICAN AGENT FOR **NEC** RF, MICROWAVE & OPTOELECTRONIC SEMICONDUCTORS

**CEL** CALIFORNIA EASTERN LABORATORIES • Headquarters • 4590 Patrick Henry Drive • Santa Clara, CA 95054-1817 • (408) 988-3500 • Telex 34-6393 • FAX (408) 988-0279  
DATA SUBJECT TO CHANGE WITHOUT NOTICE

Internet: <http://WWW.CEL.COM>

04/24/2002

Subject: Compliance with EU Directives

CEL certifies, to its knowledge, that semiconductor and laser products detailed below are compliant with the requirements of European Union (EU) Directive 2002/95/EC Restriction on Use of Hazardous Substances in electrical and electronic equipment (RoHS) and the requirements of EU Directive 2003/11/EC Restriction on Penta and Octa BDE.

CEL Pb-free products have the same base part number with a suffix added. The suffix –A indicates that the device is Pb-free. The –AZ suffix is used to designate devices containing Pb which are exempted from the requirement of RoHS directive (\*). In all cases the devices have Pb-free terminals. All devices with these suffixes meet the requirements of the RoHS directive.

This status is based on CEL’s understanding of the EU Directives and knowledge of the materials that go into its products as of the date of disclosure of this information.

Restricted Substance per RoHS	Concentration Limit per RoHS (values are not yet fixed)	Concentration contained in CEL devices	
		-A	-AZ
Lead (Pb)	< 1000 PPM	Not Detected	(*)
Mercury	< 1000 PPM	Not Detected	
Cadmium	< 100 PPM	Not Detected	
Hexavalent Chromium	< 1000 PPM	Not Detected	
PBB	< 1000 PPM	Not Detected	
PBDE	< 1000 PPM	Not Detected	

If you should have any additional questions regarding our devices and compliance to environmental standards, please do not hesitate to contact your local representative.

**Important Information and Disclaimer:** Information provided by CEL on its website or in other communications concerning the substance content of its products represents knowledge and belief as of the date that it is provided. CEL bases its knowledge and belief on information provided by third parties and makes no representation or warranty as to the accuracy of such information. Efforts are underway to better integrate information from third parties. CEL has taken and continues to take reasonable steps to provide representative and accurate information but may not have conducted destructive testing or chemical analysis on incoming materials and chemicals. CEL and CEL suppliers consider certain information to be proprietary, and thus CAS numbers and other limited information may not be available for release.

In no event shall CEL’s liability arising out of such information exceed the total purchase price of the CEL part(s) at issue sold by CEL to customer on an annual basis.

See CEL Terms and Conditions for additional clarification of warranties and liability.