



SD56120M

RF POWER Transistors, LDMOST plastic family N-Channel enhancement-mode lateral MOSFETs

General features

- Excellent thermal stability
- Common source configuration Push-pull
- $P_{OUT} = 120W$ with 13dB gain @ 860MHz / 32V
- BeO free package
- Internal input matching

Description

The SD56120M is a common source N-Channel enhancement-mode lateral Field-Effect RF power transistor designed for broadband commercial and industrial applications at frequencies up to 1.0 GHz. The SD56120M is designed for high gain and broadband performance operating in common source mode at 32 V. Its internal matching makes it ideal for TV broadcast applications requiring high linearity.

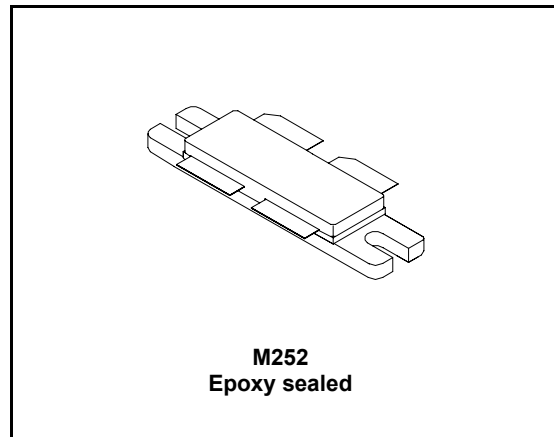

Pin connection

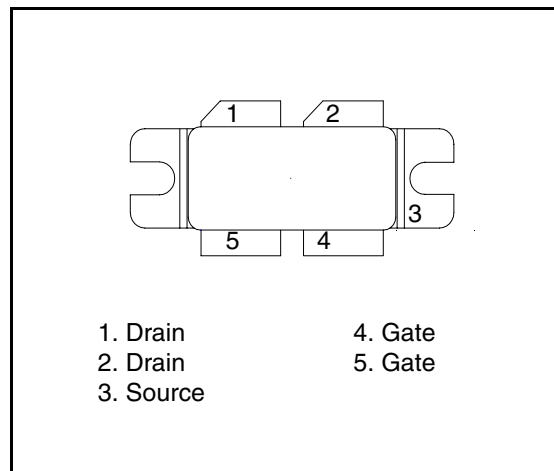

Order codes

Part number	Package	Branding
SD56120M	M252	SD56120M

Contents

1	Electrical data	3
	1.1 Maximum ratings	3
	1.2 Thermal data	3
2	Electrical characteristics	4
	2.1 Static	4
	2.2 Dynamic	4
3	Impedances	5
4	Typical performance	6
5	Package mechanical data	11
6	Revision history	13

1 Electrical data

1.1 Maximum ratings

Table 1. Absolute maximum ratings ($T_{CASE} = 25^{\circ}C$)

Symbol	Parameter	Value	Unit
$V_{(BR)DSS}$	Drain-Source Voltage	65	V
V_{GS}	Gate-Source Voltage	± 20	V
I_D	Drain Current	14	A
P_{DISS}	Power Dissipation (@ $T_c = 70^{\circ}C$)	236	W
T_j	Max. Operating Junction Temperature	200	$^{\circ}C$
T_{STG}	Storage Temperature	-65 to +150	$^{\circ}C$

1.2 Thermal data

Table 2. Thermal data

Symbol	Parameter	Value	Unit
R_{thJC}	Junction - case thermal resistance	0.55	$^{\circ}C/W$

2 Electrical characteristics

$$T_{\text{CASE}} = +25\text{ }^{\circ}\text{C}$$

2.1 Static

Table 3. Static (per section)

Symbol	Test conditions		Min	Typ	Max	Unit
$V_{(\text{BR})\text{DSS}}$	$V_{\text{GS}} = 0\text{ V}$	$I_{\text{DS}} = 10\text{ mA}$	65			V
I_{DSS}	$V_{\text{GS}} = 0\text{ V}$	$V_{\text{DS}} = 28\text{ V}$			1	μA
I_{GSS}	$V_{\text{GS}} = 20\text{ V}$	$V_{\text{DS}} = 0\text{ V}$			1	μA
$V_{\text{GS(Q)}}$	$V_{\text{DS}} = 28\text{ V}$	$I_{\text{D}} = 100\text{ mA}$	2.0		5.0	V
$V_{\text{DS(ON)}}$	$V_{\text{GS}} = 10\text{ V}$	$I_{\text{D}} = 3\text{ A}$		0.7	0.8	V
G_{FS}	$V_{\text{DS}} = 10\text{ V}$	$I_{\text{D}} = 3\text{ A}$		3		mho
$C_{\text{ISS}}^{(1)}$	$V_{\text{GS}} = 0\text{ V}$	$V_{\text{DS}} = 28\text{ V}$		221		pF
C_{OSS}	$V_{\text{GS}} = 0\text{ V}$	$V_{\text{DS}} = 28\text{ V}$		48.9		pF
C_{RSS}	$V_{\text{GS}} = 0\text{ V}$	$V_{\text{DS}} = 28\text{ V}$		2.25		pF

1. Includes Internal Input Moscap.

2.2 Dynamic

Table 4. Dynamic

Symbol	Test conditions		Min	Typ	Max	Unit
P_{OUT}	$V_{\text{DD}} = 32\text{ V}$	$I_{\text{DQ}} = 400\text{ mA}$	120			W
G_{PS}	$V_{\text{DD}} = 32\text{ V}$	$I_{\text{DQ}} = 400\text{ mA}$	13	16		dB
h_{D}	$V_{\text{DD}} = 32\text{ V}$	$I_{\text{DQ}} = 400\text{ mA}$	50			%
Load mismatch	$V_{\text{DD}} = 32\text{ V}$	$I_{\text{DQ}} = 400\text{ mA}$	10:1			VSWR

3 Impedances

Figure 1. Current conventions

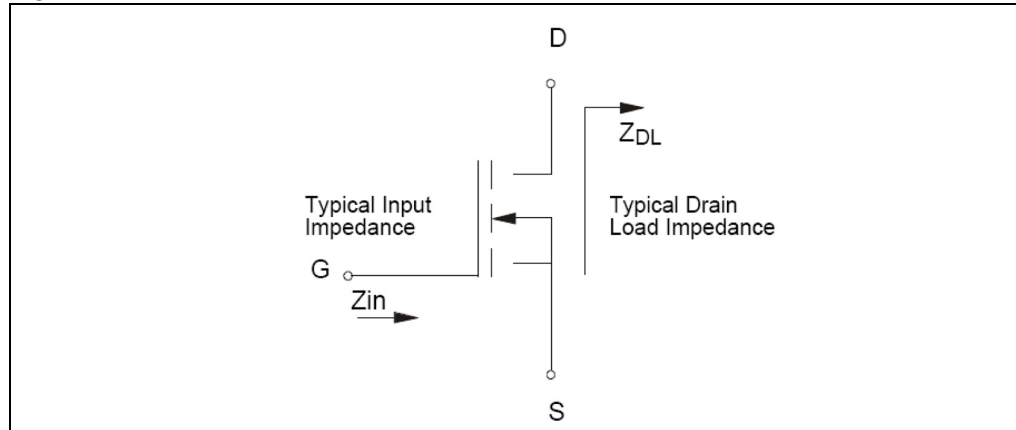

Table 5. Impedance data

Freq. (MHz)	$Z_{IN} (\Omega)$	$Z_{DL} (\Omega)$
860 MHz	$5.57 + j 3.488$	$4.21 - j 2.88$

Note: Measured drain to drain and gate to gate respectively.

4 Typical performance

Figure 2. Capacitance vs drain voltage

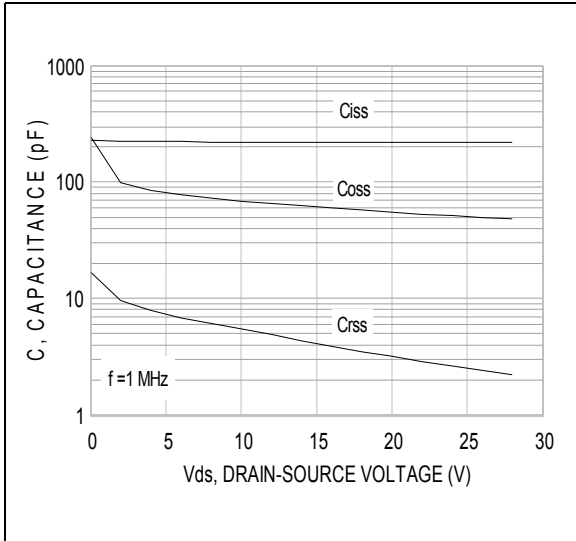

Figure 3. Gate-source voltage vs case temperature

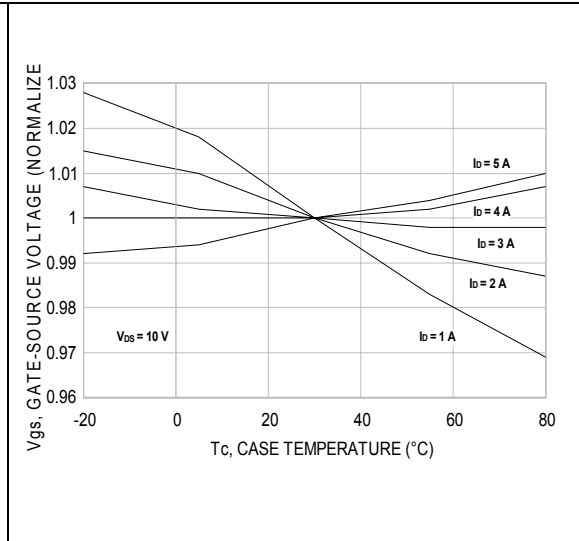

Figure 4. Drain current vs gate voltage

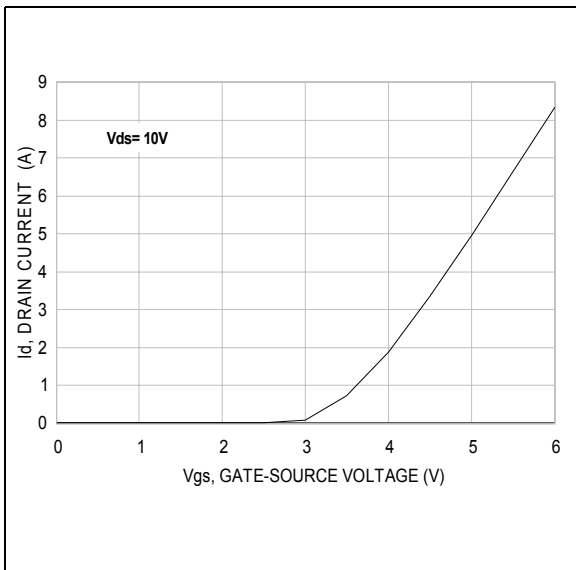

Figure 5. Output power & efficiency vs input power

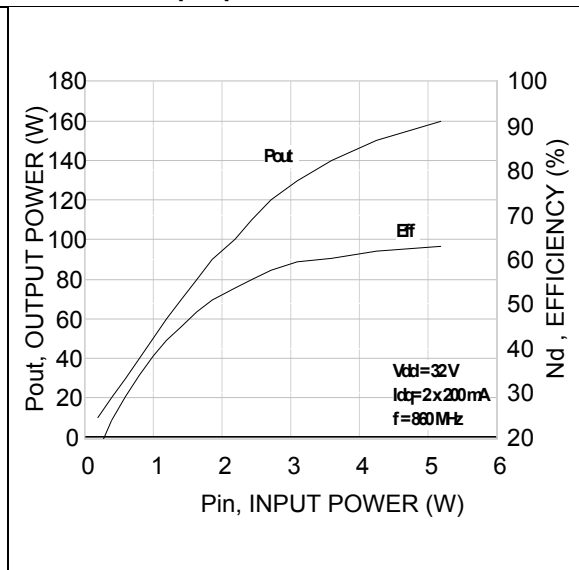

Figure 6. Power gain vs output power

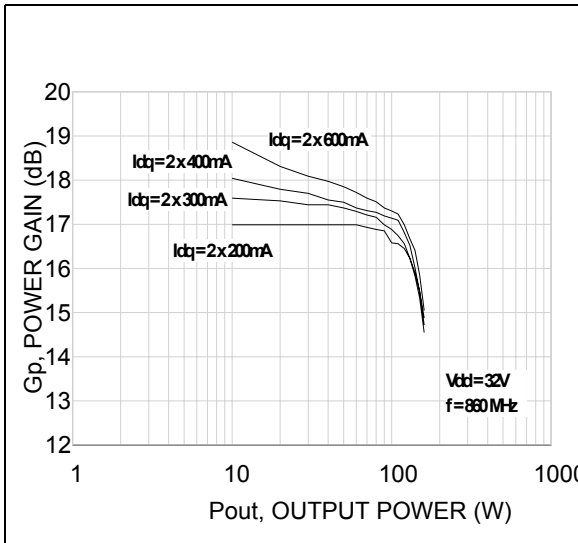

Figure 7. Intermodulation distortion vs output power

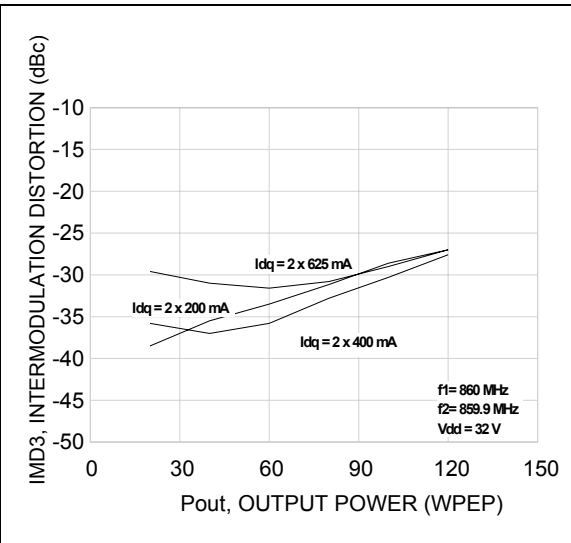

Figure 8. Output power vs drain voltage

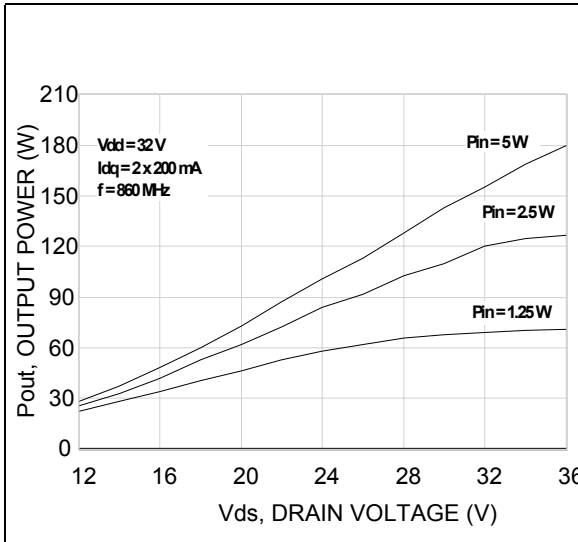
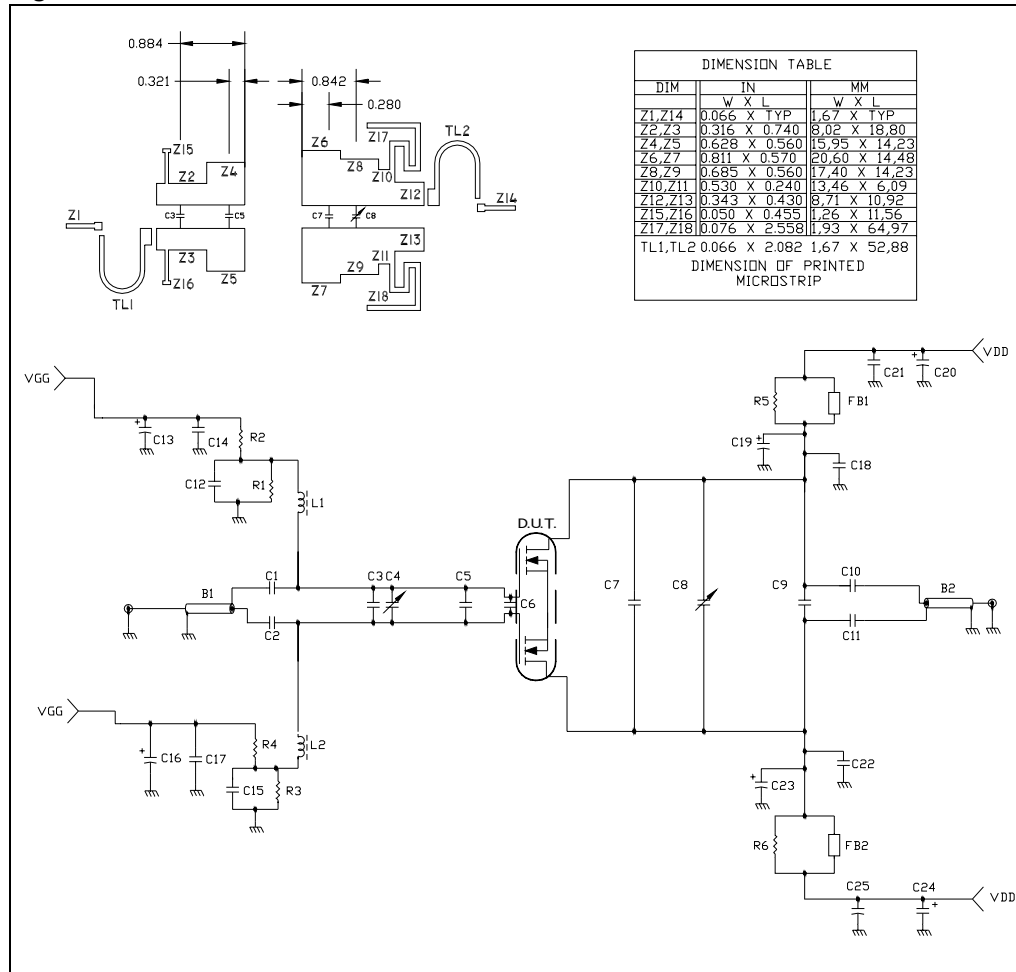

Figure 9. Test circuit schematic



- 1 C3 and C4 adjacent to each other
- 2 Gap between ground & transmission line = 0.056 [1.42] TYP.

Table 6. Test circuit component part list

Component	Description
C1, C2, C10, C11	51 pF ATC 100B SURFACE MOUNT CERAMIC CHIP CAPACITOR
C3	9.1 pF ATC 100B SURFACE MOUNT CERAMIC CHIP CAPACITOR
C4, C8	0.6 - 4.5 GIGATRIM VARIABLE CAPACITOR
C5, C9	5.6 pF ATC 100B SURFACE MOUNT CERAMIC CHIP CAPACITOR
C6	12 pF ATC 100A SURFACE MOUNT CERAMIC CHIP CAPACITOR
C7	13 pF ATC 100B SURFACE MOUNT CERAMIC CHIP CAPACITOR
C12, C15, C18, C22	91 pF ATC 100B SURFACE MOUNT CERAMIC CHIP CAPACITOR
C13, C16, C20, C24	10 μ F 50V ALUMINUM ELECTROLYTIC RADIAL LEAD CAPACITOR
C14, C17, C21, C25	0.1 μ F 500V SURFACE MOUNT CERAMIC CHIP CAPACITOR
C19, C23	100 μ F 63V ALUMINUM ELECTROLYTIC RADIAL LEAD CAPACITOR
R1, R2, R3, R4	200 OHM 1/4 W SURFACE MOUNT CHIP RESISTOR
R5, R6	1.8 OHM 1/4 W SURFACE MOUNT CHIP RESISTOR
B1, B2	BALUN, 25 OHM SEMI-RIDGE OD="0.141", 2.37 LG COAXIAL CABLE OR EQUIVALENT
L1, L2	CHIP INDICATOR 10 nH SURFACE MOUNT COIL
FB1, FB2	SURFACE MOUNT EMI SHIELD BEAD
PCB	WOVEN GLASS REINFORCED / CERAMIC FILLED 0.030" THK $\epsilon_r = 3.48$, 2 Oz ED CU BOTH SIDES

Figure 10. Test fixture

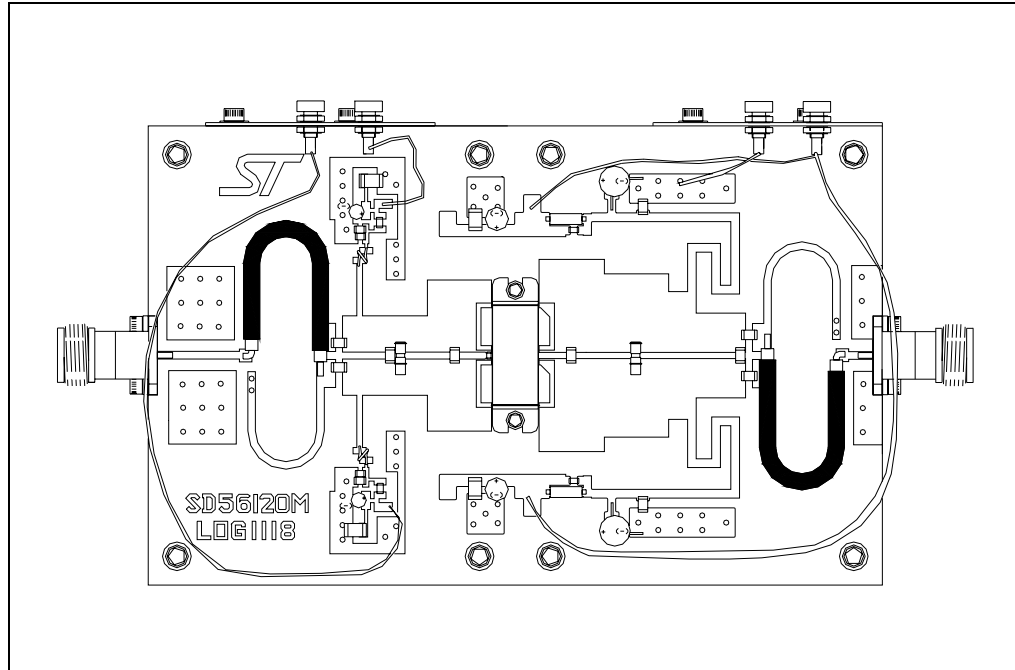
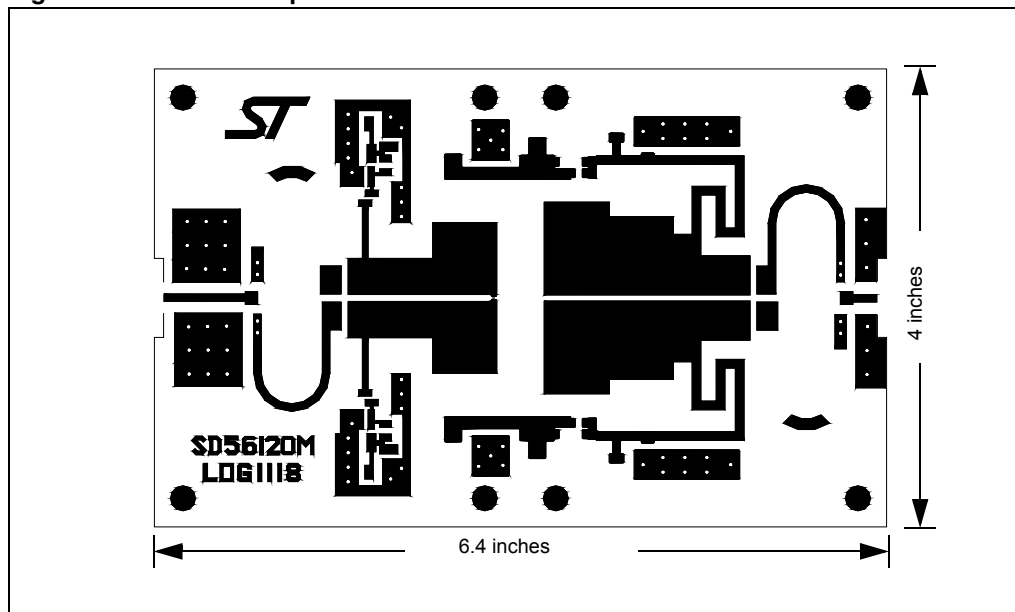

Figure 11. Test circuit photomaster



5 Package mechanical data

In order to meet environmental requirements, ST offers these devices in ECOPACK® packages. These packages have a Lead-free second level interconnect . The category of second level interconnect is marked on the package and on the inner box label, in compliance with JEDEC Standard JESD97. The maximum ratings related to soldering conditions are also marked on the inner box label. ECOPACK is an ST trademark. ECOPACK specifications are available at: www.st.com

Table 7. M252 (.400 x .860 4L BAL N/HERM W/FLG) mechanical data

Dim.	mm.			Inch		
	Min	Typ	Max	Min	Typ	Max
A	8.13		8.64	.320		.340
B		10.80			.425	
C	3.00		3.30	.118		.130
D	9.65		9.91	.380		.390
E	2.16		2.92	.085		.115
F	21.97		22.23	.865		.875
G		27.94			1.100	
H	33.91		34.16	1.335		1.345
I	0.10		0.15	.004		.006
J	1.52		1.78	.060		.070
K	2.36		2.74	.093		.108
L	4.57		5.33	.180		.210
M	9.96		10.34	.392		.407
N	21.64		22.05	.852		.868

Figure 12. Package dimensions

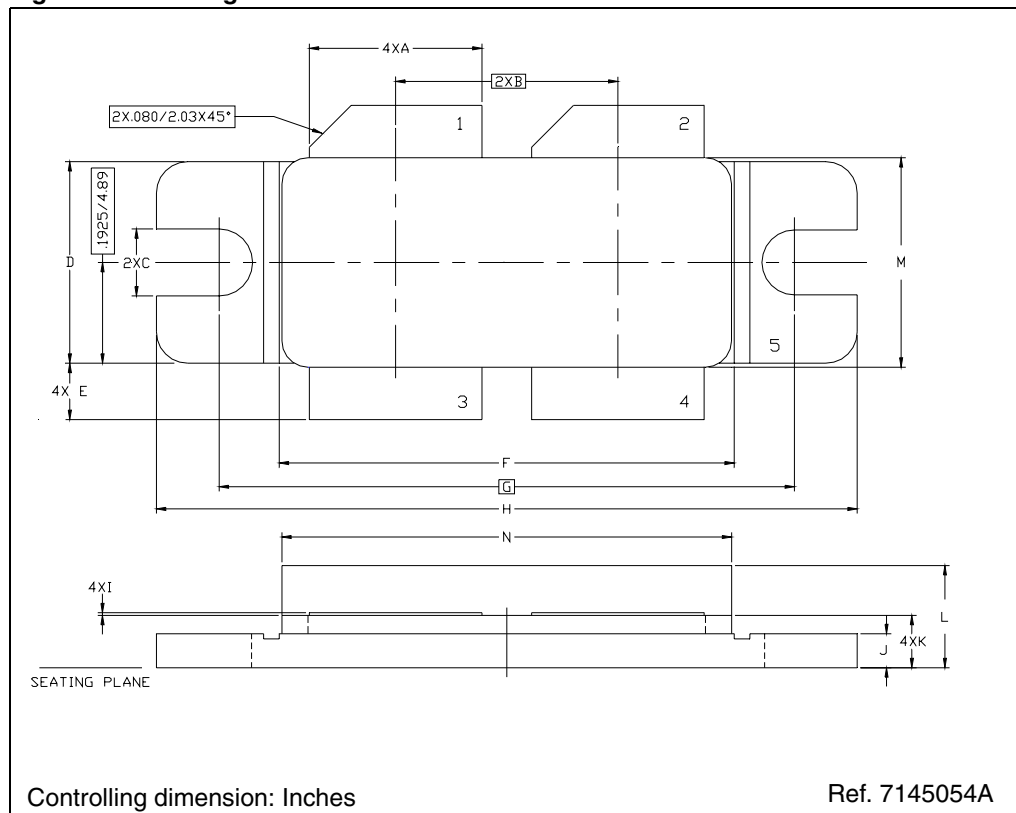

6 Revision history

Table 8. Revision history

Date	Revision	Changes
13-Jul-2006	10	New template, added lead free info

Please Read Carefully:

Information in this document is provided solely in connection with ST products. STMicroelectronics NV and its subsidiaries ("ST") reserve the right to make changes, corrections, modifications or improvements, to this document, and the products and services described herein at any time, without notice.

All ST products are sold pursuant to ST's terms and conditions of sale.

Purchasers are solely responsible for the choice, selection and use of the ST products and services described herein, and ST assumes no liability whatsoever relating to the choice, selection or use of the ST products and services described herein.

No license, express or implied, by estoppel or otherwise, to any intellectual property rights is granted under this document. If any part of this document refers to any third party products or services it shall not be deemed a license grant by ST for the use of such third party products or services, or any intellectual property contained therein or considered as a warranty covering the use in any manner whatsoever of such third party products or services or any intellectual property contained therein.

UNLESS OTHERWISE SET FORTH IN ST'S TERMS AND CONDITIONS OF SALE ST DISCLAIMS ANY EXPRESS OR IMPLIED WARRANTY WITH RESPECT TO THE USE AND/OR SALE OF ST PRODUCTS INCLUDING WITHOUT LIMITATION IMPLIED WARRANTIES OF MERCHANTABILITY, FITNESS FOR A PARTICULAR PURPOSE (AND THEIR EQUIVALENTS UNDER THE LAWS OF ANY JURISDICTION), OR INFRINGEMENT OF ANY PATENT, COPYRIGHT OR OTHER INTELLECTUAL PROPERTY RIGHT.

UNLESS EXPRESSLY APPROVED IN WRITING BY AN AUTHORIZED ST REPRESENTATIVE, ST PRODUCTS ARE NOT RECOMMENDED, AUTHORIZED OR WARRANTED FOR USE IN MILITARY, AIR CRAFT, SPACE, LIFE SAVING, OR LIFE SUSTAINING APPLICATIONS, NOR IN PRODUCTS OR SYSTEMS WHERE FAILURE OR MALFUNCTION MAY RESULT IN PERSONAL INJURY, DEATH, OR SEVERE PROPERTY OR ENVIRONMENTAL DAMAGE. ST PRODUCTS WHICH ARE NOT SPECIFIED AS "AUTOMOTIVE GRADE" MAY ONLY BE USED IN AUTOMOTIVE APPLICATIONS AT USER'S OWN RISK.

Resale of ST products with provisions different from the statements and/or technical features set forth in this document shall immediately void any warranty granted by ST for the ST product or service described herein and shall not create or extend in any manner whatsoever, any liability of ST.

ST and the ST logo are trademarks or registered trademarks of ST in various countries.

Information in this document supersedes and replaces all information previously supplied.

The ST logo is a registered trademark of STMicroelectronics. All other names are the property of their respective owners.

© 2006 STMicroelectronics - All rights reserved

STMicroelectronics group of companies

Australia - Belgium - Brazil - Canada - China - Czech Republic - Finland - France - Germany - Hong Kong - India - Israel - Italy - Japan - Malaysia - Malta - Morocco - Singapore - Spain - Sweden - Switzerland - United Kingdom - United States of America

www.st.com