



PD57045-E PD57045S-E

RF POWER transistor, LdmoST plastic family N-channel enhancement-mode, lateral MOSFETs

Features

- Excellent thermal stability
- Common source configuration
- $P_{OUT} = 45\text{ W}$ with 13dB gain @ 945 MHz / 28 V
- New RF plastic package

Description

The device is a common source N-channel, enhancement-mode lateral field-effect RF power transistor. It is designed for high gain, broad band commercial and industrial applications. It operates at 28 V in common source mode at frequencies of up to 1 GHz. The device boasts the excellent gain, linearity and reliability of ST's latest LDMOS technology mounted in the first true SMD plastic RF power package, PowerSO-10RF. Device's superior linearity performance makes it an ideal solution for base station applications. The PowerSO-10 plastic package, designed to offer high reliability, is the first ST JEDEC approved, high power SMD package. It has been specially optimized for RF needs and offers excellent RF performances and ease of assembly. Mounting recommendations are available in www.st.com/rf/ (look for application note AN1294).

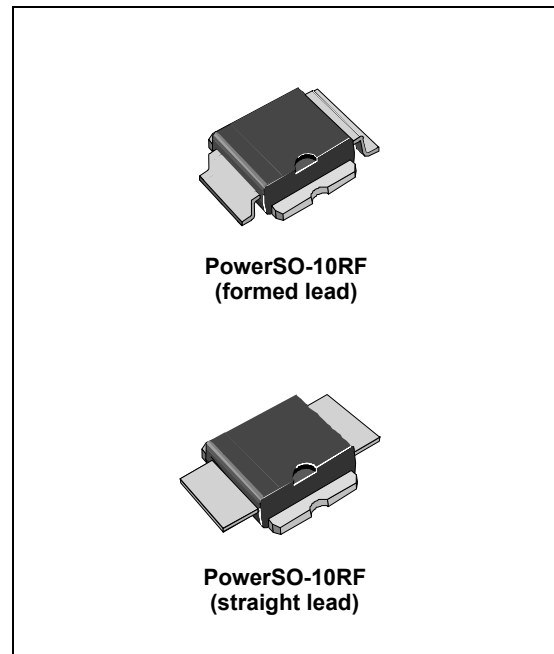

Figure 1. Pin connection

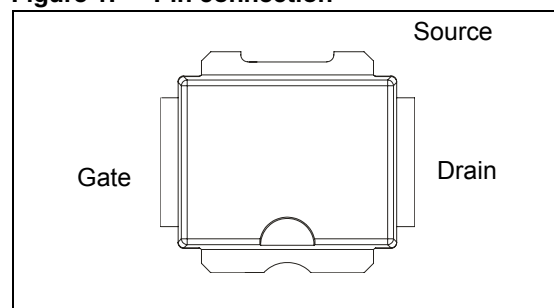

Table 1. Device summary

Order code	Package	Packing
PD57045-E	PowerSO-10RF (formed lead)	Tube
PD57045S-E	PowerSO-10RF (straight lead)	Tube
PD57045TR-E	PowerSO-10RF (formed lead)	Tape and reel
PD57045STR-E	PowerSO-10RF (straight lead)	Tape and reel

Contents

1	Electrical data	3
	1.1 Maximum ratings	3
	1.2 Thermal data	3
2	Electrical characteristics	4
	2.1 Static	4
	2.2 Dynamic	4
	2.3 Moisture sensitivity level	4
3	Impedance	5
4	Typical performance	6
	4.1 PD57045S-E	7
5	Test circuit	9
6	Common source s-parameter	12
7	Package mechanical data	14
8	Revision history	19

1 Electrical data

1.1 Maximum ratings

Table 2. Absolute maximum ratings ($T_{CASE} = 25^{\circ}C$)

Symbol	Parameter	Value	Unit
$V_{(BR)DSS}$	Drain-Source Voltage	65	V
V_{GS}	Gate-Source Voltage	± 20	V
I_D	Drain Current	5	A
P_{DISS}	Power Dissipation (@ $T_c = 70^{\circ}C$)	73	W
T_J	Max. Operating Junction Temperature	165	$^{\circ}C$
T_{STG}	Storage Temperature	-65 to +150	$^{\circ}C$

1.2 Thermal data

Table 3. Thermal data

Symbol	Parameter	Value	Unit
R_{thJC}	Junction - case thermal resistance	1.2	$^{\circ}C/W$

2 Electrical characteristics

$T_{CASE} = +25\text{ }^{\circ}\text{C}$

2.1 Static

Table 4. Static

Symbol	Test conditions		Min	Typ	Max	Unit
$V_{(BR)DSS}$	$V_{GS} = 0$	$I_{DS} = 1\text{ mA}$	65			V
I_{DSS}	$V_{GS} = 0$	$V_{DS} = 28\text{ V}$			1	μA
I_{GSS}	$V_{GS} = 20\text{ V}$	$V_{DS} = 0$			1	μA
$V_{GS(Q)}$	$V_{DS} = 28\text{ V}$	$I_D = 250\text{ mA}$	2.0		5.0	V
$V_{DS(ON)}$	$V_{GS} = 10\text{ V}$	$I_D = 3\text{ A}$		0.7	0.9	V
g_{FS}	$V_{DS} = 10\text{ V}$	$I_D = 4\text{ A}$	2.0	2.7		mho
C_{ISS}	$V_{GS} = 0$	$V_{DS} = 28\text{ V}$		86		pF
C_{OSS}	$V_{GS} = 0$	$V_{DS} = 28\text{ V}$		47		pF
C_{RSS}	$V_{GS} = 0$	$V_{DS} = 28\text{ V}$		3.6		pF

2.2 Dynamic

Table 5. Dynamic

Symbol	Test conditions		Min.	Typ.	Max.	Unit
P_{1dB}	$V_{DD} = 28\text{ V}$	$I_{DQ} = 250\text{ mA}$ $f = 945\text{ MHz}$	45			W
G_P	$V_{DD} = 28\text{ V}$	$I_{DQ} = 250\text{ mA}$ $P_{OUT} = 45\text{ W}$ $f = 945\text{ MHz}$	13	14.5		dB
η_D	$V_{DD} = 28\text{ V}$	$I_{DQ} = 250\text{ mA}$ $P_{OUT} = 45\text{ W}$ $f = 945\text{ MHz}$	50			%
Load mismatch	$V_{DD} = 28\text{ V}$	$I_{DQ} = 250\text{ mA}$ $P_{OUT} = 45\text{ W}$ $f = 945\text{ MHz}$ All phase angles	10:1			VSWR

2.3 Moisture sensitivity level

Table 6. Moisture sensitivity level

Test methodology	Rating
J-STD-020B	MSL 3

3 Impedance

Figure 2. Current conventions

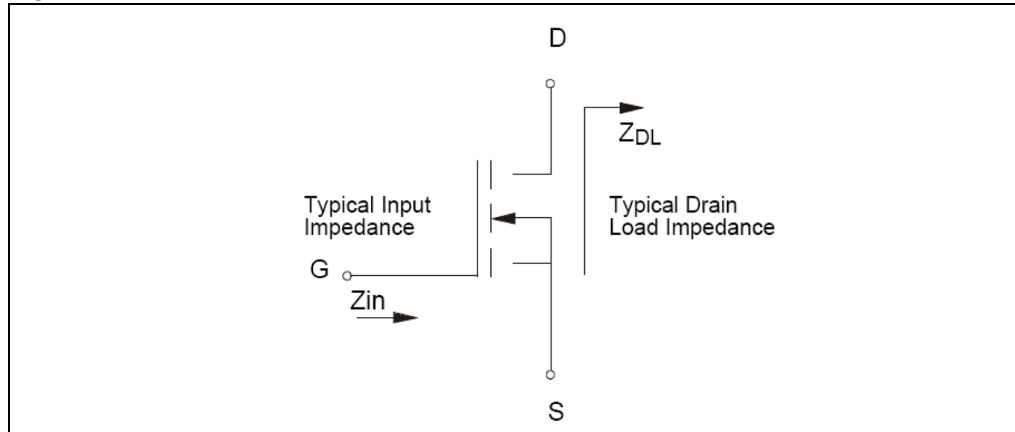

Table 7. Impedance data

Freq. (MHz)	$Z_{IN} (\Omega)$	$Z_{DL} (\Omega)$
925	.71 + j 2.32	1.29 - j .35
945	.69 + j 2.92	1.25 - j .29
960	.55 + j 2.78	1.18 - j .83

4 Typical performance

Figure 3. Capacitance vs drain voltage

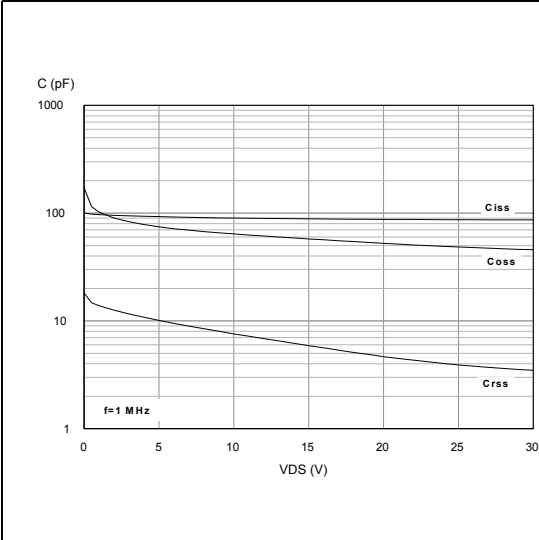

Figure 4. Drain current vs gate voltage

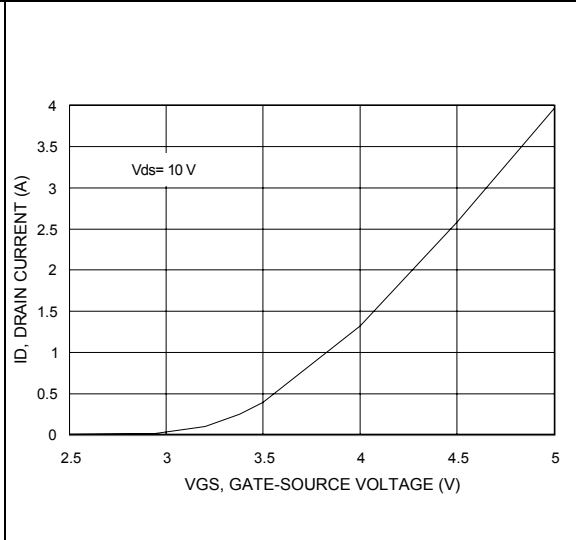

Figure 5. Gate-source voltage vs case temperature

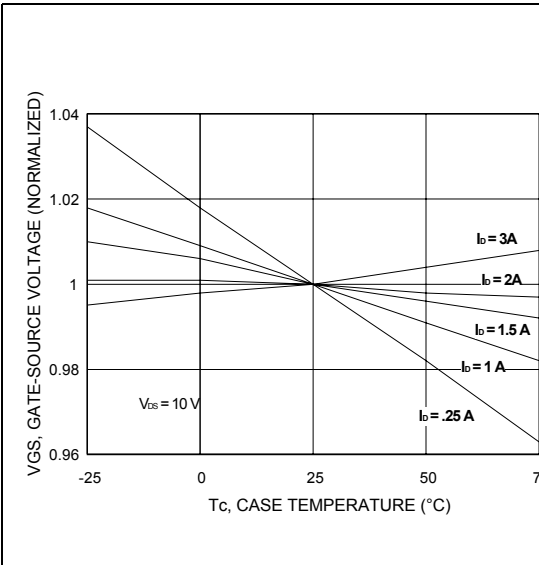
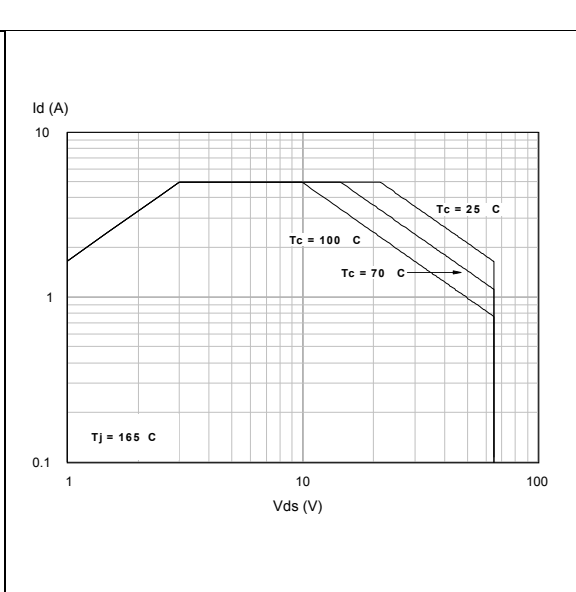

Figure 6. Safe operating area



4.1 PD57045S-E

Figure 7. Output power vs input power

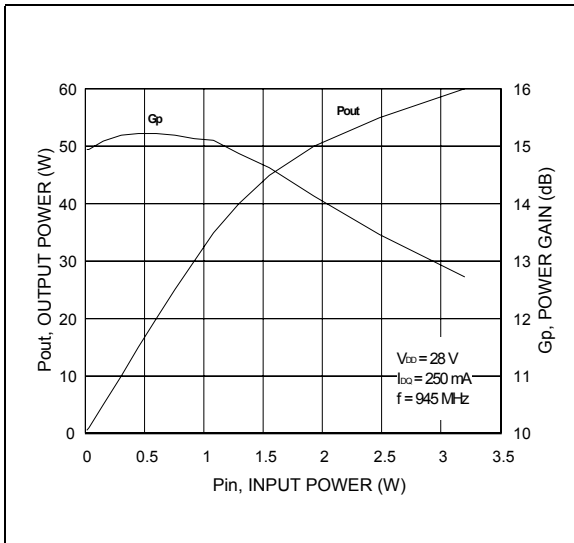

Figure 8. Input return loss vs output power

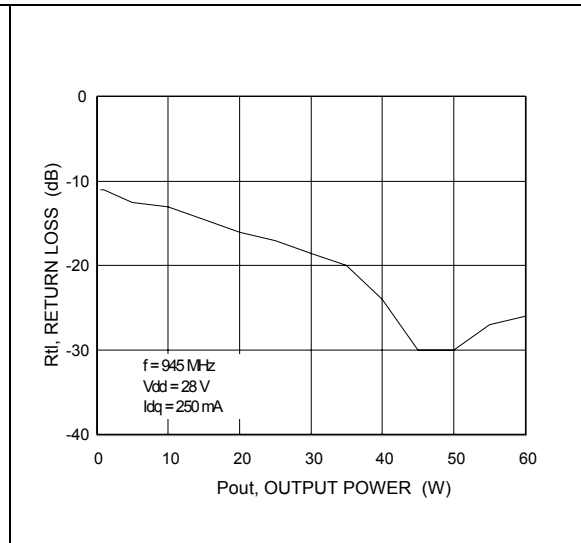

Figure 9. Power gain vs output power

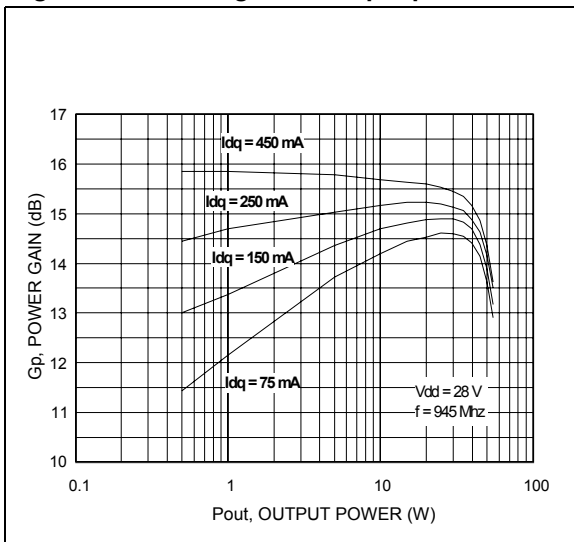

Figure 10. Drain efficiency vs output power

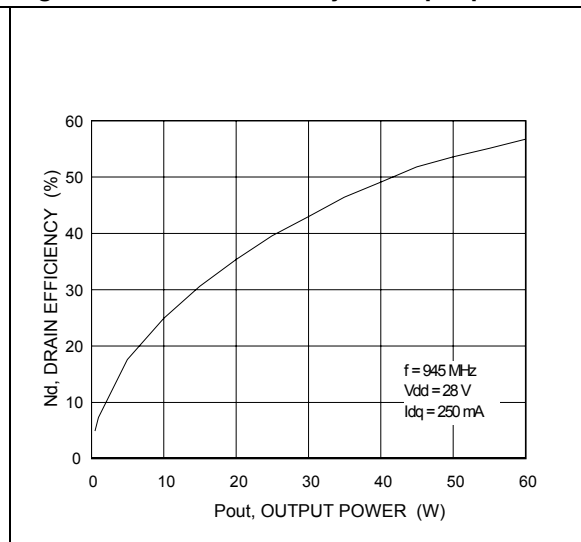

Figure 11. Output power vs bias current

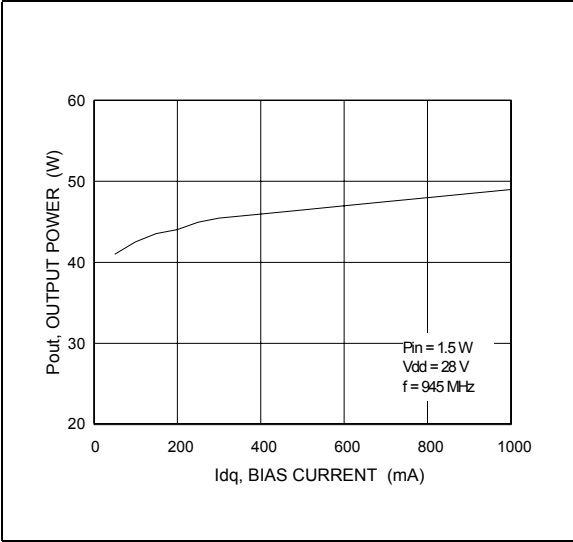

Figure 12. Drain efficiency vs bias current

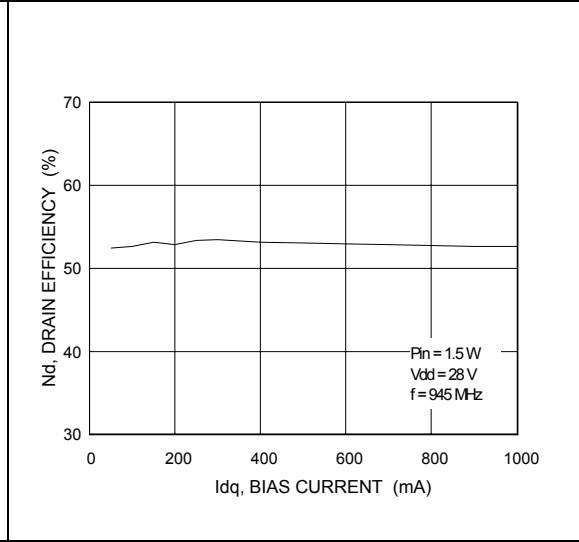

Figure 13. Output power vs drain voltage

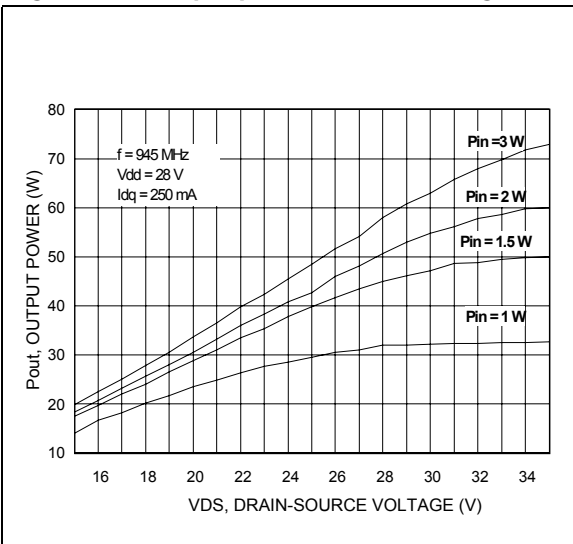
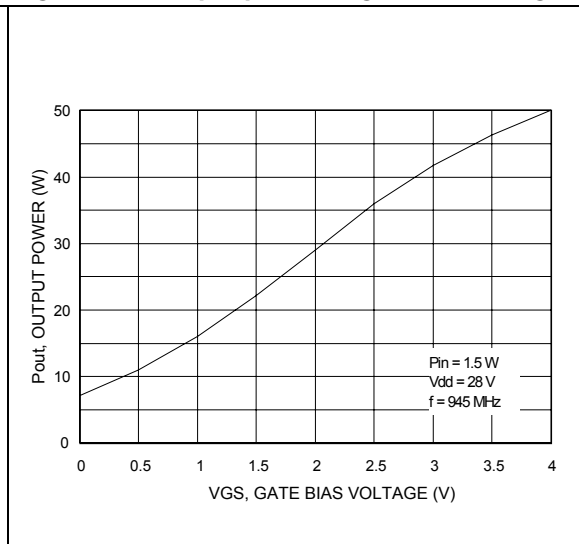
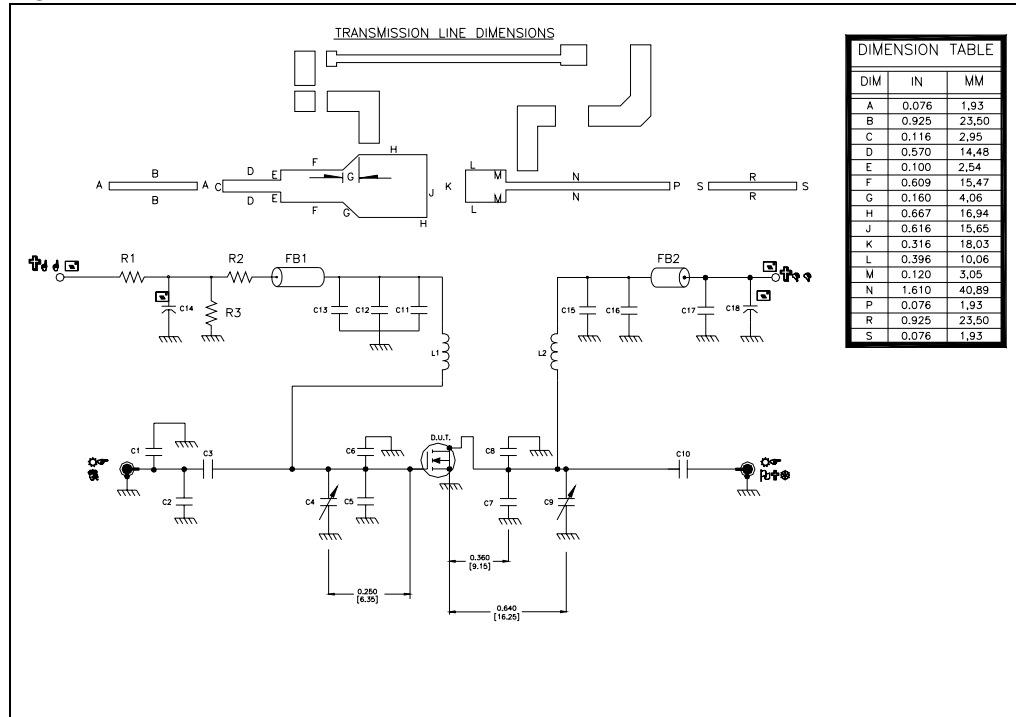

Figure 14. Output power vs gate bias voltage



5 Test circuit

Figure 15. Test circuit schematic



- Note:
- 1 Dimensions at component symbols are reference for component placement.
 - 2 Gap between ground & transmission line = 0.056 [1.42] +0.002 [0.05] -0.000 [0.00] typ.
 - 3 Dimensions of input and output component from edge of transmission lines.

Table 8. Test circuit component part list

Component	Description
L1,L2	Inductor, 5 turns air wound #22AWG, ID 0.059{1.49}, nylon coated magnet wire
FB1,FB2	Shield bead surface mount EMI
R1	18 kΩ, 1 W surface mount chip resistor
R2	4.7 MΩ, 1 W surface mount chip resistor
R3	120 Ω, 2 W surface mount chip resistor
C1,C2	3 pF ATC 100B surface mount ceramic chip capacitor
C3,C10,C11,C15	47 pF ATC 100B surface mount ceramic chip capacitor
C4,C9	0.8-8.0 pF giga trim variable capacitor
C5,C6,C7,C8	7.5 pF ATC 100B surface mount ceramic chip capacitor
C12	1000 pF ATC 700B surface mount ceramic chip capacitor
C13,C17	0.1 μF/500 V surface mount ceramic chip capacitor
C14	10 μF/50 V aluminum electrolytic radial lead capacitor
C16	100 pF ATC 100B surface mount ceramic chip capacitor
C18	220 μF/63 V aluminum electrolytic radial lead capacitor
Board	Roger, ultra lam 2000, THK 0.030", εr = 2.55 2oz. ED cu 2 sides.

Figure 16. Test circuit

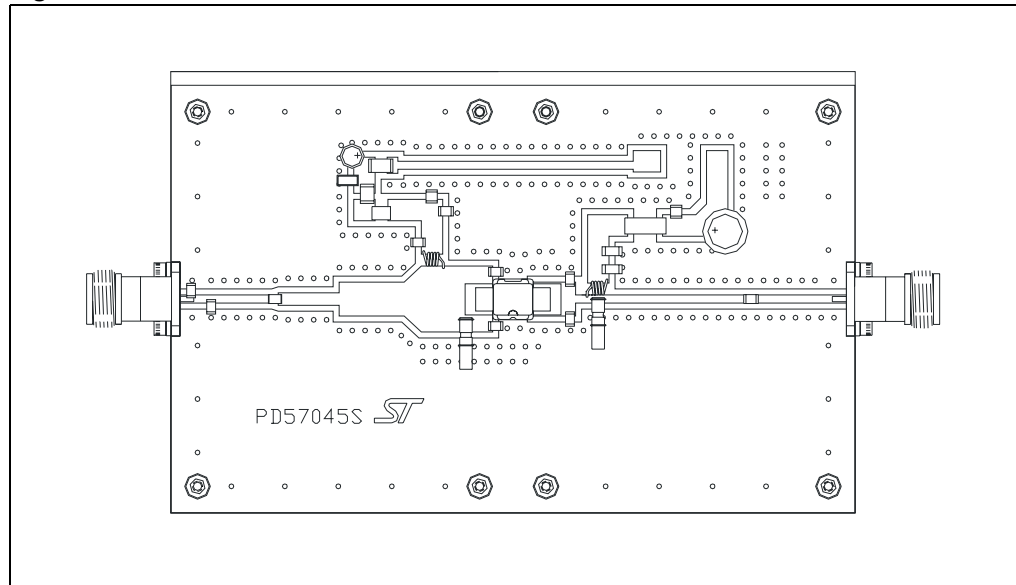
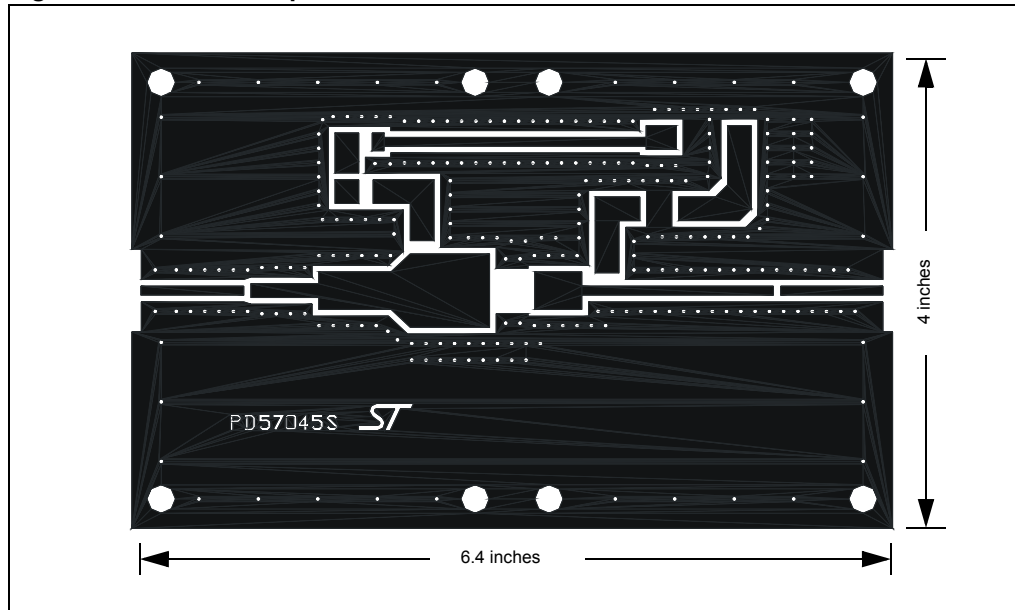

Figure 17. Test circuit photomaster



6 Common source s-parameter

Table 9. S-parameter for PD57045S-E ($V_{DS} = 13.5\text{ V}$ $I_{DS} = 1.5\text{ A}$)

Freq (MHz)	$ S_{11} $	$\angle S_{11}$	$ S_{21} $	$\angle S_{21}$	$ S_{12} $	$\angle S_{12}$	$ S_{22} $	$\angle S_{22}$
50	0.825	-170	14.34	85	0.014	-1	0.819	-171
100	0.875	-173	6.94	79	0.013	-6	0.824	-175
150	0.895	-175	4.67	75	0.013	-10	0.828	-175
200	0.908	-176	3.44	70	0.013	-14	0.837	-176
250	0.910	-177	2.70	65	0.012	-16	0.842	-176
300	0.916	-178	2.20	60	0.012	-18	0.854	-176
350	0.922	-178	1.82	55	0.011	-23	0.864	-176
400	0.926	-179	1.55	51	0.010	-25	0.874	-176
450	0.933	-179	1.32	47	0.010	-25	0.883	-177
500	0.937	-179	1.14	44	0.008	-25	0.893	-177
550	0.942	-180	1.00	40	0.008	-24	0.901	-177
600	0.946	180	0.88	37	0.007	-25	0.912	-177
650	0.949	180	0.79	34	0.007	-25	0.915	-178
700	0.951	179	0.70	32	0.006	-20	0.922	-178
750	0.954	179	0.63	29	0.005	-23	0.926	-179
800	0.958	178	0.57	27	0.005	-14	0.932	-179
850	0.961	178	0.52	24	0.004	-6	0.932	-180
900	0.963	178	0.47	22	0.004	3	0.942	179
950	0.964	177	0.44	20	0.004	1	0.942	180
1000	0.966	177	0.40	18	0.004	7	0.943	179
1050	0.967	176	0.37	16	0.003	26	0.946	179
1100	0.966	176	0.35	15	0.003	51	0.949	178
1150	0.969	176	0.32	13	0.003	56	0.950	179
1200	0.970	175	0.30	11	0.004	62	0.953	179
1250	0.970	175	0.29	9	0.004	55	0.967	178
1300	0.971	175	0.26	7	0.004	65	0.972	176
1350	0.972	174	0.25	6	0.004	71	0.958	176
1400	0.972	174	0.23	4	0.005	81	0.961	176
1450	0.970	174	0.22	3	0.006	91	0.958	175
1500	0.970	173	0.20	2	0.007	100	0.963	175

Table 10. S-parameter for PD57002S-E ($V_{DS} = 28\text{ V}$ $I_{DS} = 1.5\text{ A}$)

Freq (MHz)	S ₁₁	S ₁₁ < Φ	S ₂₁	S ₂₁ < Φ	S ₁₂	S ₁₂ < Φ	S ₂₂	S ₂₂ < Φ
50	0.829	-161	20.72	92	0.012	2	0.718	-166
100	0.872	-168	10.33	82	0.011	-6	0.731	-170
150	0.897	-172	6.84	74	0.011	-10	0.745	-171
200	0.910	-174	5.02	68	0.010	-14	0.765	-171
250	0.913	-175	3.86	61	0.010	-17	0.783	-171
300	0.922	-176	3.10	55	0.009	-23	0.803	-171
350	0.928	-176	2.53	50	0.009	-25	0.823	-172
400	0.934	-177	2.12	45	0.008	-27	0.839	-172
450	0.941	-178	1.79	41	0.007	-26	0.856	-172
500	0.946	-178	1.53	37	0.006	-26	0.872	-173
550	0.949	-179	1.32	34	0.005	-27	0.884	-174
600	0.955	-179	1.16	31	0.005	-24	0.898	-174
650	0.959	-180	1.03	27	0.004	-18	0.902	-175
700	0.960	180	0.91	25	0.004	-17	0.914	-175
750	0.963	179	0.81	22	0.003	-7	0.919	-176
800	0.967	179	0.73	19	0.003	-1	0.928	-176
850	0.968	178	0.67	17	0.003	11	0.927	-177
900	0.968	178	0.60	15	0.003	28	0.937	-178
950	0.972	178	0.55	12	0.003	36	0.939	-178
1000	0.972	177	0.50	11	0.003	56	0.94	-179
1050	0.972	177	0.49	9	0.003	56	0.944	-179
1100	0.972	176	0.43	7	0.004	63	0.950	-180
1150	0.974	176	0.40	5	0.004	66	0.950	-179
1200	0.975	176	0.37	4	0.005	72	0.950	-180
1250	0.975	175	0.35	3	0.006	75	0.968	180
1300	0.976	175	0.32	0	0.006	77	0.973	178
1350	0.977	174	0.30	-1	0.006	81	0.960	178
1400	0.976	174	0.28	-2	0.006	84	0.960	177
1450	0.973	174	0.26	-3	0.007	98	0.958	177
1500	0.973	174	0.25	-4	0.008	102	0.963	176

7 Package mechanical data

In order to meet environmental requirements, ST offers these devices in different grades of ECOPACK[®] packages, depending on their level of environmental compliance. ECOPACK[®] specifications, grade definitions and product status are available at: www.st.com. ECOPACK[®] is an ST trademark.

Table 11. PowerSO-10RF formed lead (Gull Wing) mechanical data

Dim.	mm.			Inch		
	Min.	Typ.	Max.	Min.	Typ.	Max.
A1	0	0.05	0.1	0.	0.0019	0.0038
A2	3.4	3.5	3.6	0.134	0.137	0.142
A3	1.2	1.3	1.4	0.046	0.05	0.054
A4	0.15	0.2	0.25	0.005	0.007	0.009
a		0.2			0.007	
b	5.4	5.53	5.65	0.212	0.217	0.221
c	0.23	0.27	0.32	0.008	0.01	0.012
D	9.4	9.5	9.6	0.370	0.374	0.377
D1	7.4	7.5	7.6	0.290	0.295	0.298
E	13.85	14.1	14.35	0.544	0.555	0.565
E1	9.3	9.4	9.5	0.365	0.37	0.375
E2	7.3	7.4	7.5	0.286	0.292	0.294
E3	5.9	6.1	6.3	0.231	0.24	0.247
F		0.5			0.019	
G		1.2			0.047	
L	0.8	1	1.1	0.030	0.039	0.042
R1			0.25			0.01
R2		0.8			0.031	
T	2 deg	5 deg	8 deg	2 deg	5 deg	8 deg
T1		6 deg			6 deg	
T2		10 deg			10 deg	

Note: Resin protrusions not included (max value: 0.15 mm per side)

Figure 18. Package dimensions

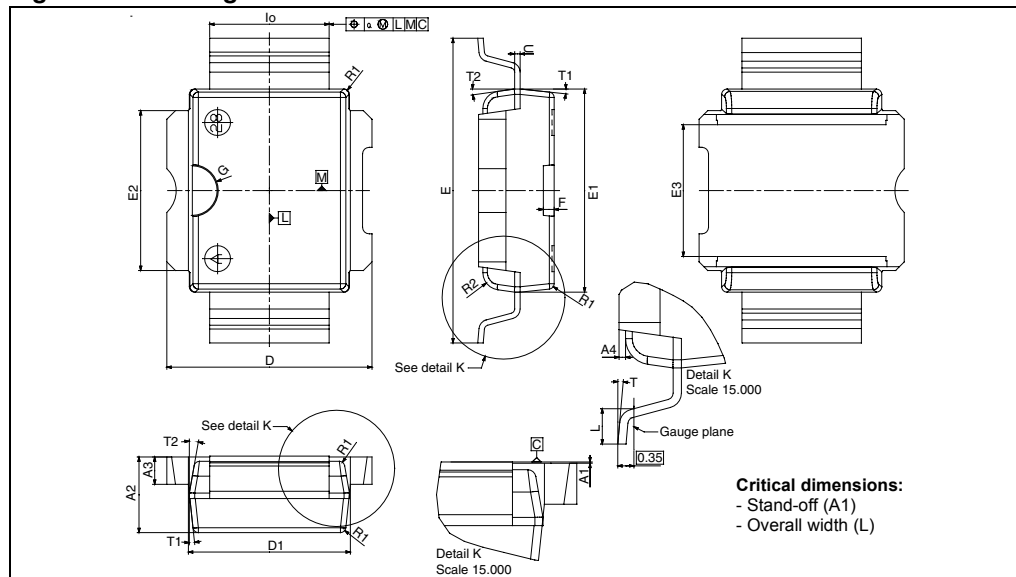

Table 12. PowerSO-10RF straight lead mechanical data

Dim.	mm.			Inch		
	Min.	Typ.	Max.	Min.	Typ.	Max.
A1	1.62	1.67	1.72	0.064	0.065	0.068
A2	3.4	3.5	3.6	0.134	0.137	0.142
A3	1.2	1.3	1.4	0.046	0.05	0.054
A4	0.15	0.2	0.25	0.005	0.007	0.009
a		0.2			0.007	
b	5.4	5.53	5.65	0.212	0.217	0.221
c	0.23	0.27	0.32	0.008	0.01	0.012
D	9.4	9.5	9.6	0.370	0.374	0.377
D1	7.4	7.5	7.6	0.290	0.295	0.298
E	15.15	15.4	15.65	0.595	0.606	0.615
E1	9.3	9.4	9.5	0.365	0.37	0.375
E2	7.3	7.4	7.5	0.286	0.292	0.294
E3	5.9	6.1	6.3	0.231	0.24	0.247
F		0.5			0.019	
G		1.2			0.047	
R1			0.25			0.01
R2		0.8			0.031	
T1		6 deg			6 deg	
T2		10 deg			10 deg	

Note: Resin protrusions not included (max value: 0.15 mm per side)

Figure 19. Package dimensions

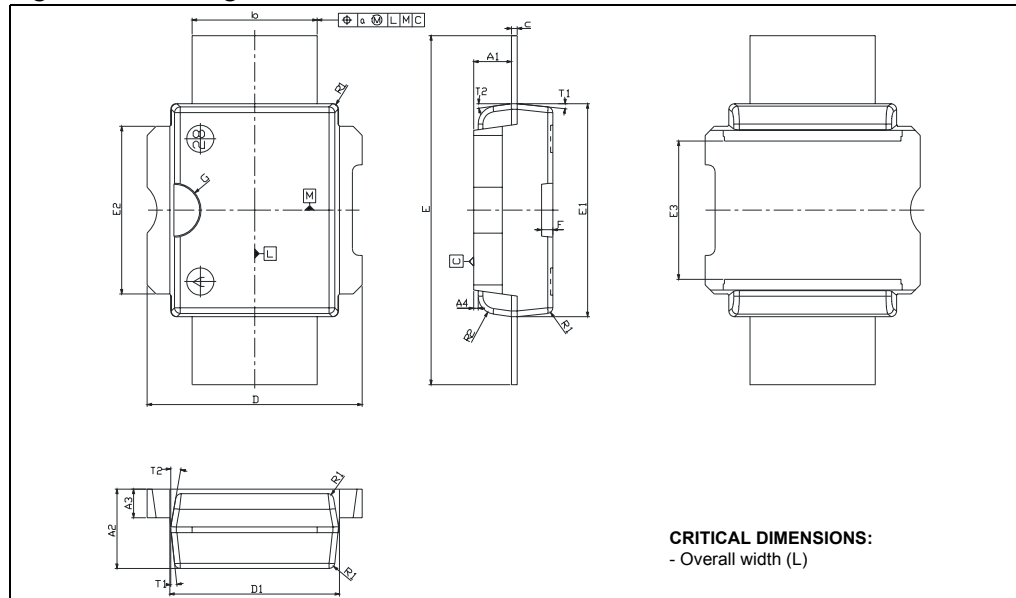

Figure 20. Tube information

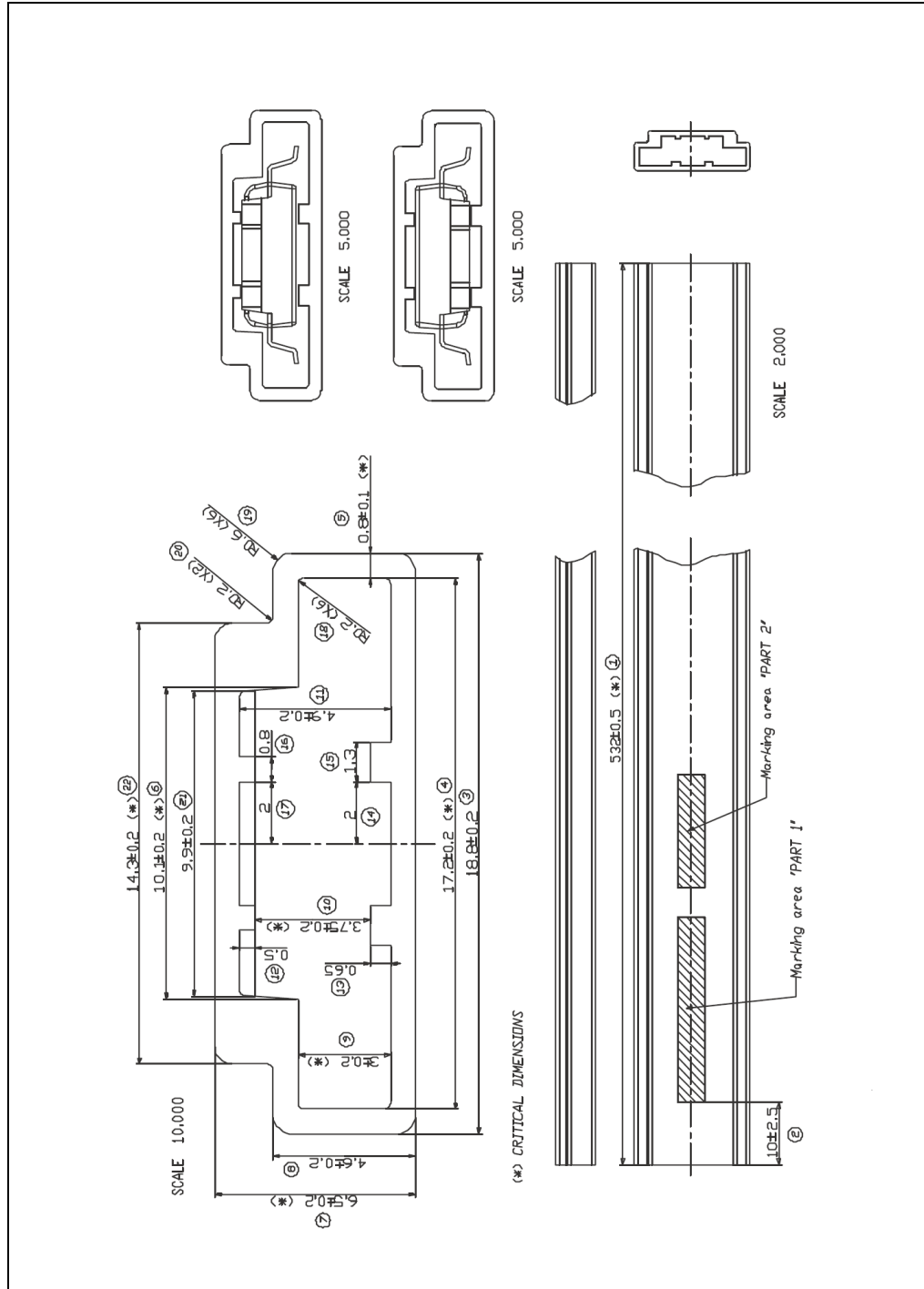
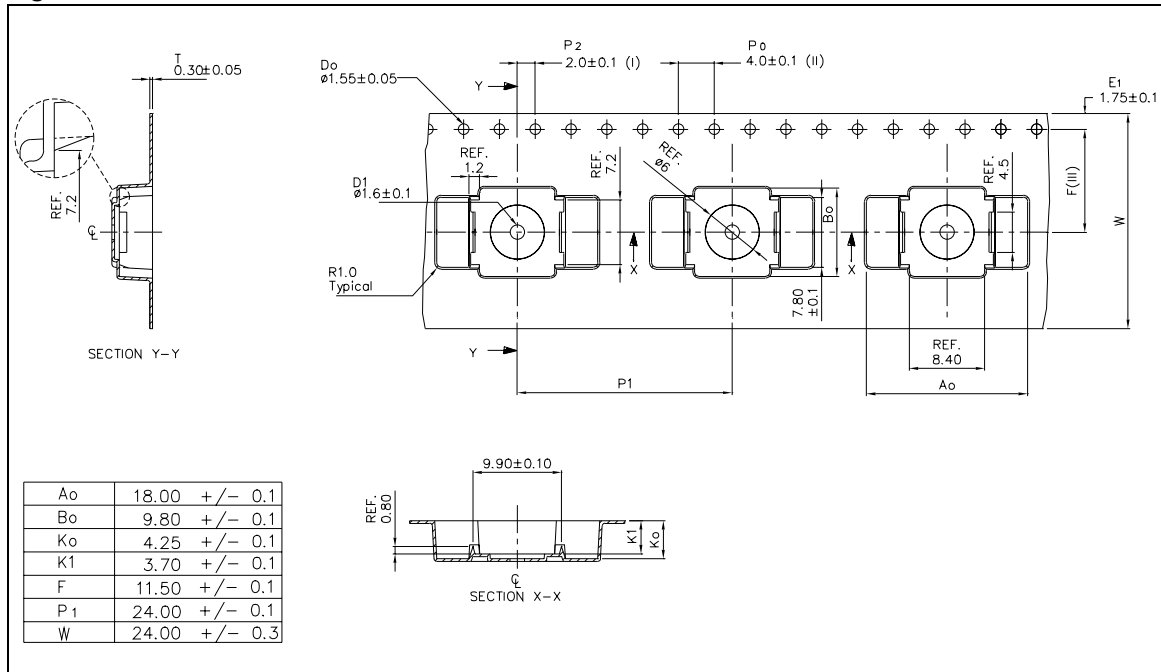

Figure 21. Reel information



8 Revision history

Table 13. Document revision history

Date	Revision	Changes
08-Aug-2006	1	Initial release.
01-Jun-2010	2	Added: Table 6: Moisture sensitivity level.

Please Read Carefully:

Information in this document is provided solely in connection with ST products. STMicroelectronics NV and its subsidiaries ("ST") reserve the right to make changes, corrections, modifications or improvements, to this document, and the products and services described herein at any time, without notice.

All ST products are sold pursuant to ST's terms and conditions of sale.

Purchasers are solely responsible for the choice, selection and use of the ST products and services described herein, and ST assumes no liability whatsoever relating to the choice, selection or use of the ST products and services described herein.

No license, express or implied, by estoppel or otherwise, to any intellectual property rights is granted under this document. If any part of this document refers to any third party products or services it shall not be deemed a license grant by ST for the use of such third party products or services, or any intellectual property contained therein or considered as a warranty covering the use in any manner whatsoever of such third party products or services or any intellectual property contained therein.

UNLESS OTHERWISE SET FORTH IN ST'S TERMS AND CONDITIONS OF SALE ST DISCLAIMS ANY EXPRESS OR IMPLIED WARRANTY WITH RESPECT TO THE USE AND/OR SALE OF ST PRODUCTS INCLUDING WITHOUT LIMITATION IMPLIED WARRANTIES OF MERCHANTABILITY, FITNESS FOR A PARTICULAR PURPOSE (AND THEIR EQUIVALENTS UNDER THE LAWS OF ANY JURISDICTION), OR INFRINGEMENT OF ANY PATENT, COPYRIGHT OR OTHER INTELLECTUAL PROPERTY RIGHT.

UNLESS EXPRESSLY APPROVED IN WRITING BY AN AUTHORIZED ST REPRESENTATIVE, ST PRODUCTS ARE NOT RECOMMENDED, AUTHORIZED OR WARRANTED FOR USE IN MILITARY, AIR CRAFT, SPACE, LIFE SAVING, OR LIFE SUSTAINING APPLICATIONS, NOR IN PRODUCTS OR SYSTEMS WHERE FAILURE OR MALFUNCTION MAY RESULT IN PERSONAL INJURY, DEATH, OR SEVERE PROPERTY OR ENVIRONMENTAL DAMAGE. ST PRODUCTS WHICH ARE NOT SPECIFIED AS "AUTOMOTIVE GRADE" MAY ONLY BE USED IN AUTOMOTIVE APPLICATIONS AT USER'S OWN RISK.

Resale of ST products with provisions different from the statements and/or technical features set forth in this document shall immediately void any warranty granted by ST for the ST product or service described herein and shall not create or extend in any manner whatsoever, any liability of ST.

ST and the ST logo are trademarks or registered trademarks of ST in various countries.

Information in this document supersedes and replaces all information previously supplied.

The ST logo is a registered trademark of STMicroelectronics. All other names are the property of their respective owners.

© 2010 STMicroelectronics - All rights reserved

STMicroelectronics group of companies

Australia - Belgium - Brazil - Canada - China - Czech Republic - Finland - France - Germany - Hong Kong - India - Israel - Italy - Japan - Malaysia - Malta - Morocco - Philippines - Singapore - Spain - Sweden - Switzerland - United Kingdom - United States of America

www.st.com