

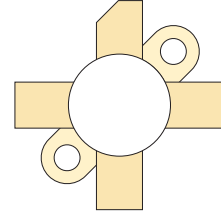

RF POWER VERTICAL MOSFET

The VRF148A is a gold-metallized silicon n-channel RF power transistor designed for broadband commercial and military applications requiring high power and gain without compromising reliability, ruggedness, or inter-modulation distortion.



FEATURES

- Improved Ruggedness $V_{(BR)DSS} = 170V$
- 30W with 20dB Typical Gain @ 30MHz, 50V
- 30W with 16dB Typical Gain @ 175MHz, 50V
- Excellent Stability & Low IMD
- Common Source Configuration
- RoHS Compliant 
- 30:1 Load VSWR Capability at Specified Operating Conditions
- Nitride Passivated
- Refractory Gold Metallization
- High Voltage Replacement for MRF148A

Maximum Ratings

All Ratings: $T_c = 25^\circ C$ unless otherwise specified

Symbol	Parameter	VRF148A	Unit
V_{DSS}	Drain-Source Voltage	170	V
I_D	Continuous Drain Current @ $T_c = 25^\circ C$	6	A
V_{GS}	Gate-Source Voltage	± 40	V
P_D	Total Device dissipation @ $T_c = 25^\circ C$	115	W
T_{STG}	Storage Temperature Range	-65 to 150	°C
T_J	Operating Junction Temperature	200	

Static Electrical Characteristics

Symbol	Parameter	Min	Typ	Max	Unit
$V_{(BR)DSS}$	Drain-Source Breakdown Voltage ($V_{GS} = 0V, I_D = 1mA$)	170			V
$V_{DS(ON)}$	On State Drain Voltage ($I_{D(ON)} = 2.5A, V_{GS} = 10V$)		3.0	5.0	
I_{DSS}	Zero Gate Voltage Drain Current ($V_{DS} = 100V, V_{GS} = 0V$)			0.1	mA
I_{GSS}	Gate-Source Leakage Current ($V_{DS} = \pm 20V, V_{GS} = 0V$)			1.0	μA
g_{fs}	Forward Transconductance ($V_{DS} = 10V, I_D = 2.5A$)	0.8			mhos
$V_{GS(TH)}$	Gate Threshold Voltage ($V_{DS} = 10V, I_D = 10mA$)	2.9	3.6	4.4	V

Thermal Characteristics

Symbol	Characteristic	Min	Typ	Max	Unit
$R_{\theta JC}$	Junction to Case Thermal Resistance			1.52	°C/W

 **CAUTION:** These Devices are Sensitive to Electrostatic Discharge. Proper Handling Procedures Should Be Followed.

Dynamic Characteristics

VRF148A

Symbol	Parameter	Test Conditions	Min	Typ	Max	Unit
C_{iss}	Input Capacitance	$V_{GS} = 0V$		160		pF
C_{oss}	Output Capacitance	$V_{DS} = 50V$		40		
C_{rss}	Reverse Transfer Capacitance	$f = 1MHz$		2.6		

Functional Characteristics

Symbol	Parameter	Min	Typ	Max	Unit
G_{PS}	$f_1 = 30MHz, V_{DD} = 50V, I_{DQ} = 100mA, P_{out} = 30W$		18		dB
G_{PS}	$f_1 = 175MHz, V_{DD} = 50V, I_{DQ} = 100mA, P_{out} = 30W$		16		
η	$f_1 = 30MHz, f_2 = 30.001MHz, V_{DD} = 50V, I_{DQ} = 100mA, 30 W_{PEP}$		40		%
η	$f_1 = 30MHz, V_{DD} = 50V, I_{DQ} = 100mA, 30 W_{CW}$		50		
IMD _(d3)	$f_1 = 30MHz, f_2 = 30.001MHz, V_{DD} = 50V, I_{DQ} = 100mA, P_{out} = 30W_{PEP}^1$		-35	-28	dB
IMD _(d11)	$f_1 = 30MHz, f_2 = 30.001MHz, V_{DD} = 50V, I_{DQ} = 100mA, P_{out} = 30W_{PEP}$		-60		
ψ	$f_1 = 30MHz, f_2 = 30.001MHz, V_{DD} = 50V, I_{DQ} = 100mA, P_{out} = 300W_{PEP}$ 30:1 VSWR - All Phase Angles	No Degradation in Output Power			

Class A Characteristics

Symbol	Test Conditions	Min	Typ	Max	Unit
G_{PS}	$f_1 = 30MHz, f_2 = 30.001MHz, V_{DD} = 50V, I_{DQ} = 1.0A, P_{out} = 10W_{PEP}$		20		dB
IMD _(d3)	$f_1 = 30MHz, f_2 = 30.001MHz, V_{DD} = 50V, I_{DQ} = 1.0A, P_{out} = 10W_{PEP}$		-50		
IMD _(d9-d13)	$f_1 = 30MHz, f_2 = 30.001MHz, V_{DD} = 50V, I_{DQ} = 1.0A, P_{out} = 10W_{PEP}$		-70		

1. To MIL-STD-1311 Version A, test method 2204B, Two Tone, Reference Each Tone

Microsemi reserves the right to change, without notice, the specifications and information contained herein.

Typical Performance Curves

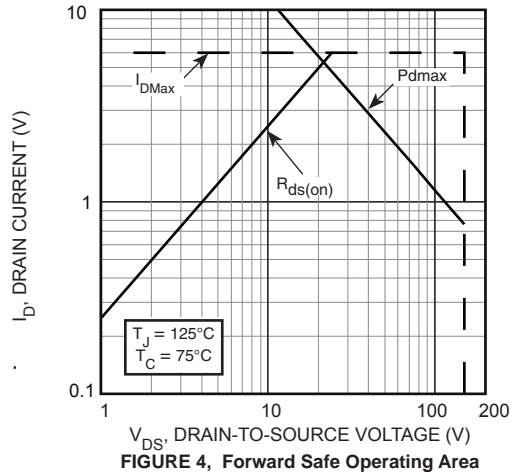
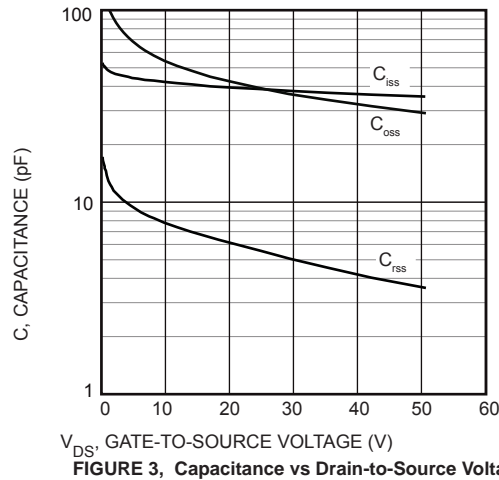
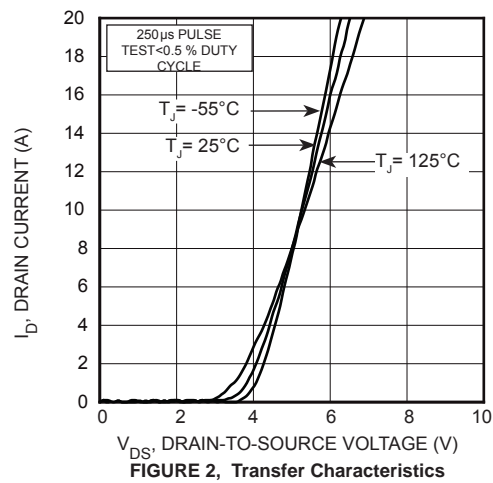
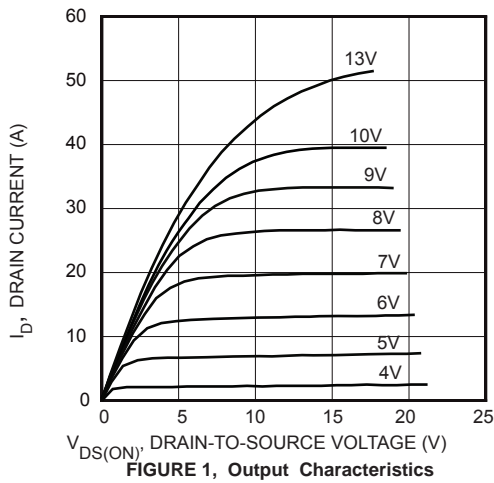

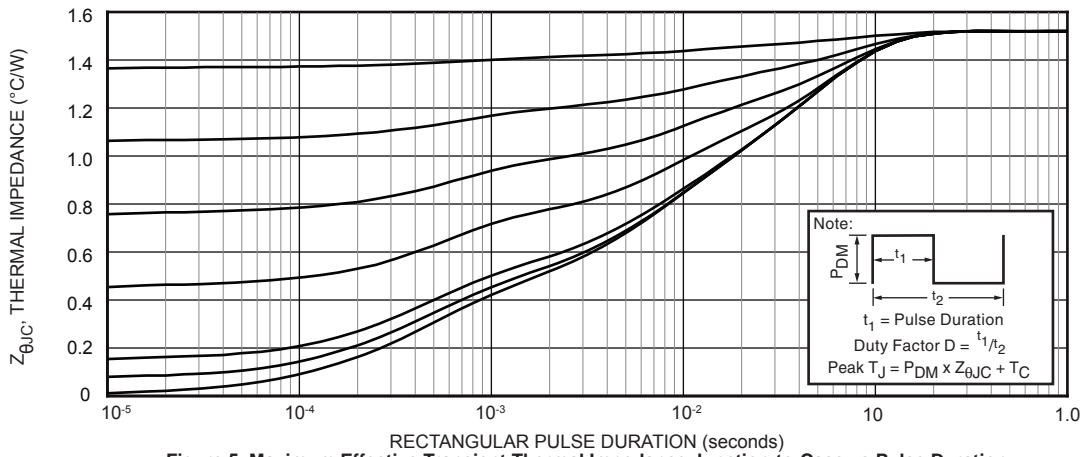

Figure 5. Maximum Effective Transient Thermal Impedance Junction-to-Case vs Pulse Duration

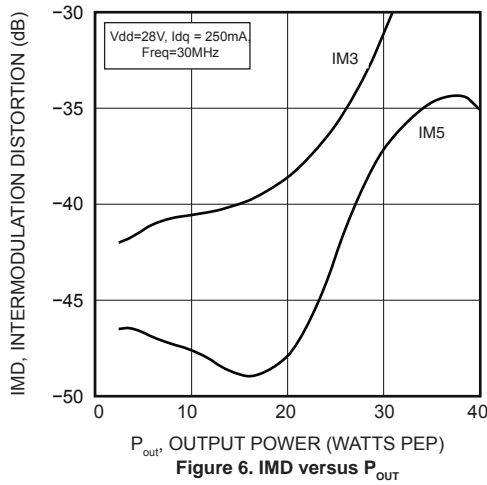

Figure 6. IMD versus P_{OUT}

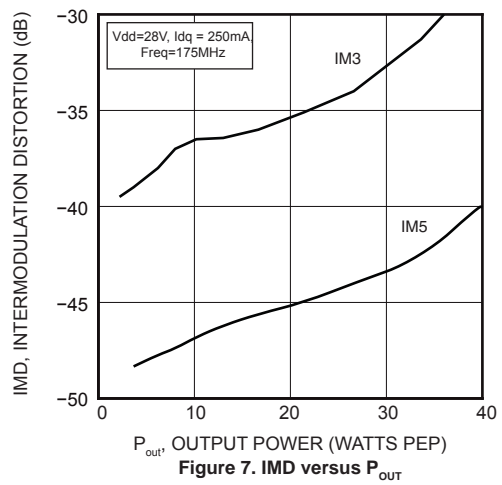

Figure 7. IMD versus P_{OUT}

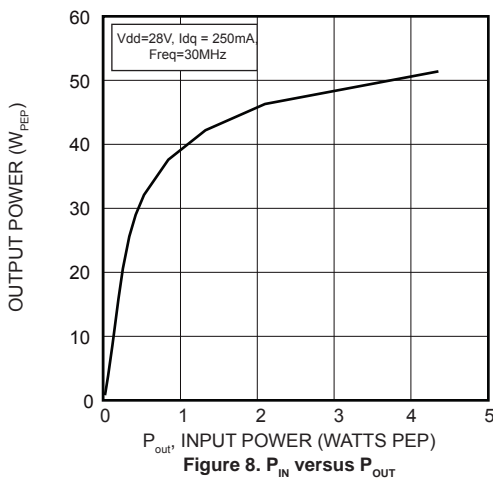

Figure 8. P_{IN} versus P_{OUT}

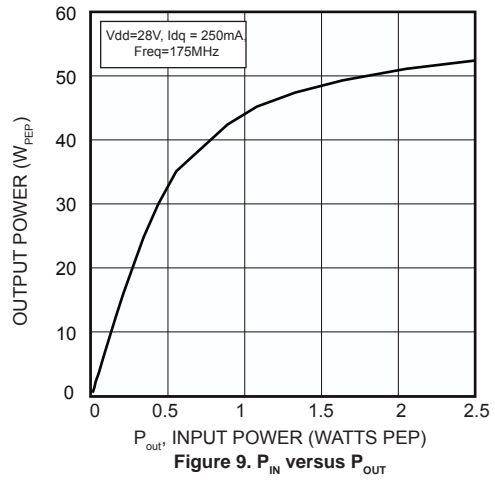
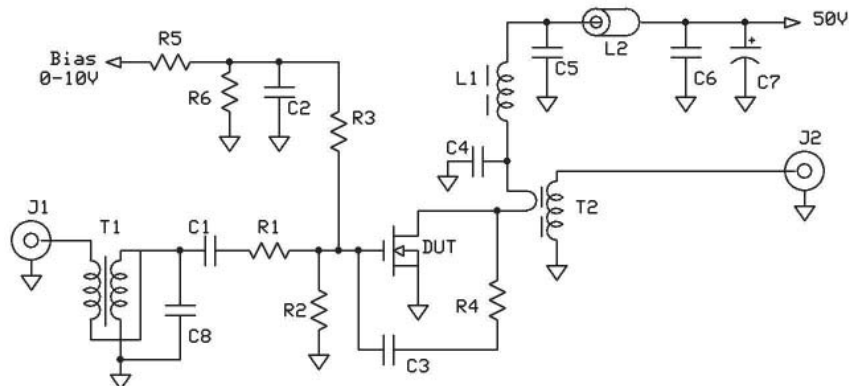

Figure 9. P_{IN} versus P_{OUT}

30 MHz test circuit



- | | |
|---|------------------------------------|
| C1-C6 - 0.1uF 100V SMT | L1 Fair-Rite 2961666631 (VK200-4B) |
| C7 - 15uF 100V Elect | L2 - two ferrite beads on #18 |
| C8 - 100 pF ATC 100B | R1 - 4.7 ohm 1/4W |
| T1 - 4:1 transformer | R2 R3 - 200 ohm 1/2 Carbn |
| T2 = 2:3 turns ratio on two ferrite beads u=125 | R4 - 470 ohm 1W |
| | R5 R6 - 2200 ohm 1/4W |

175 MHz test circuit

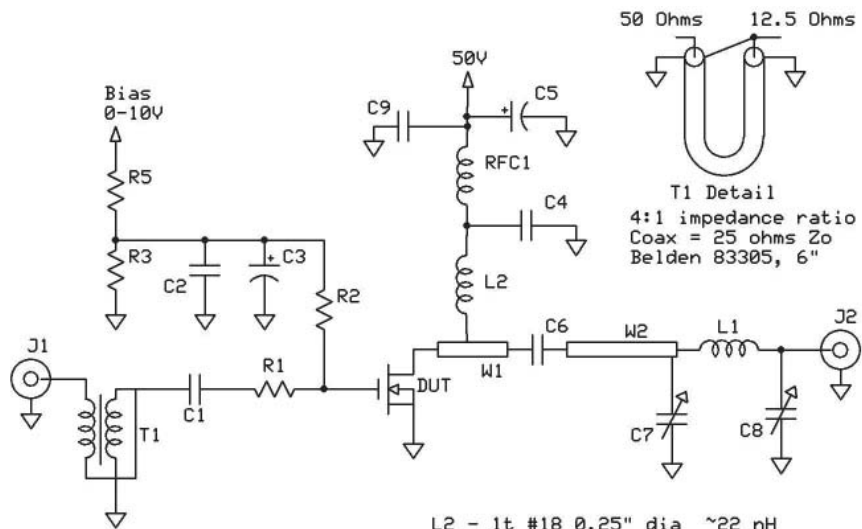

- | | |
|--------------------------------|--------------------------------------|
| C1 - 91pF ATC 100B | L2 - 1t #18 0.25" dia ~22 nH |
| C2,4,6,9 - 0.1uF 100V 1206 SMT | R1 - 1 ohm 1/4W |
| C3 - 1 uF 50 WV tant | R2 R3 R5 - 2200 ohm 1/4W |
| C5 - 15uF 100V Elect | RFC1 Fair-Rite 2961666631 (VK200-4B) |
| C7 C8 - ARCO 404 ~20pF | T1 - 4:1 transformer |
| L1 - 1t #18 0.25" dia ~25nH | W1 Stripline .23 x 0.50" |
| | W2 Stripline 1.2" x .122" (50 ohm) |

M113 Package Outline .375" SOE
 All Dimensions to be $\pm .005$

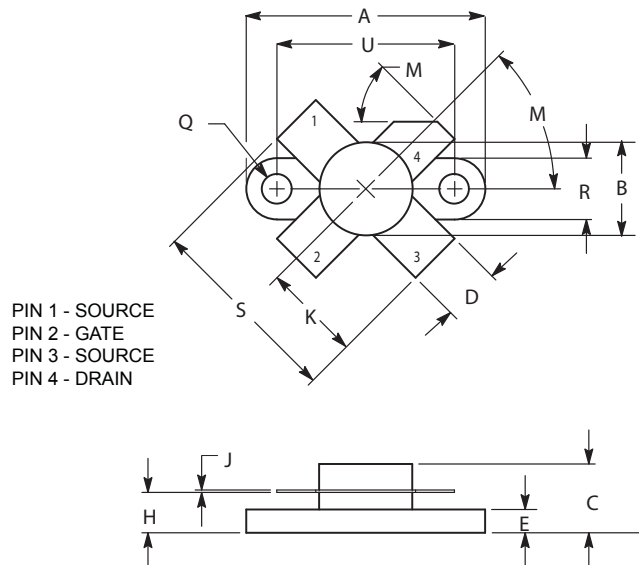

DIM	INCHES		MILLIMETERS	
	MIN	MAX	MIN	MAX
A	0.096	0.990	24.39	25.14
B	0.370	0.390	9.40	9.90
C	0.229	0.281	5.82	7.13
D	0.215	0.235	5.47	5.96
E	0.085	0.105	2.16	2.66
H	0.150	0.108	3.81	4.57
J	0.004	0.006	0.11	0.15
K	0.395	0.405	10.04	10.28
M	40	50	40	50
Q	0.113	0.130	2.88	3.30
R	0.245	0.255	6.23	6.47
S	0.790	0.810	20.07	20.57
U	0.720	0.730	18.29	18.54

Microsemi's products are covered by one or more of U.S. patents 4,895,810 5,045,903 5,089,434 5,182,234 5,019,522 5,262,336 6,503,786 5,256,583 4,748,103 5,283,202 5,231,474 5,434,095 5,528,058 6,939,743 7,352,045 and foreign patents. US and Foreign patents pending. All Rights Reserved.