

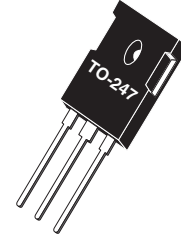

RF POWER MOSFET
 N-CHANNEL ENHANCEMENT MODE

The ARF460A and ARF460B comprise a symmetric pair of common source RF power transistors designed for push-pull scientific, commercial, medical and industrial RF power amplifier applications up to 65MHz. They have been optimized for both linear and high efficiency classes of operation.

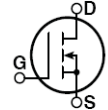

Common Source



- Specified 125 Volt, 40.68MHz Characteristics:
 - Output Power = 150 Watts.
 - Gain = 13dB (Class AB)
 - Efficiency = 75% (Class C)
- Low Cost Common Source RF Package.
- Low V_{th} thermal coefficient.
- Low Thermal Resistance.
- Optimized SOA for Superior Ruggedness
- RoHS Compliant 

Maximum Ratings

 All Ratings: $T_c = 25^\circ\text{C}$ unless otherwise specified

Symbol	Parameter	ARF460AG/BG	Unit
V_{DSS}	Drain-Source Voltage	500	V
V_{DGO}	Drain-Gate Voltage	500	
I_D	Continuous Drain Current @ $T_c = 25^\circ\text{C}$	14	A
V_{GS}	Gate-Source Voltage	± 30	V
P_D	Total Power Dissipation @ $T_c = 25^\circ\text{C}$	250	W
$R_{\theta JC}$	Junction to Case	0.50	$^\circ\text{C}/\text{W}$
T_J, T_{STG}	Operating and Storage Junction Temperature Range	-55 to 150	$^\circ\text{C}$
T_L	Lead Temperature: 0.063" from Case for 10 Sec.	300	

Static Electrical Characteristics

Symbol	Parameter	Min	Typ	Max	Unit
BV_{DSS}	Drain-Source Breakdown Voltage ($V_{GS} = 0\text{V}, I_D = 250 \mu\text{A}$)	500			V
$V_{DS(ON)}$	On State Drain Voltage ¹ ($I_{D(ON)} = 7\text{A}, V_{GS} = 10\text{V}$)			4	
I_{DSS}	Zero Gate Voltage Drain Current ($V_{DS} = V_{DSS}, V_{GS} = 0\text{V}$)			25	μA
	Zero Gate Voltage Drain Current ($V_{DS} = 0.8V_{DSS}, V_{GS} = 0, T_c = 125^\circ\text{C}$)			250	
I_{GSS}	Gate-Source Leakage Current ($V_{DS} = \pm 30\text{V}, V_{GS} = 0\text{V}$)			± 100	nA
g_{fs}	Forward Transconductance ($V_{DS} = 25\text{V}, I_D = 7\text{A}$)	3.3	5.5	8	mhos
$V_{GS(TH)}$	Gate Threshold Voltage ($V_{DS} = V_{GS}, I_D = 50\text{mA}$)	3		5	Volts

 **CAUTION:** These Devices are Sensitive to Electrostatic Discharge. Proper Handling Procedures Should Be Followed.

Dynamic Characteristics

ARF460AG/BG

Symbol	Parameter	Test Conditions	Min	Typ	Max	Unit
C_{ISS}	Input Capacitance	$V_{GS} = 0V$ $V_{DS} = 150V$ $f = 1MHz$		1200	1400	pF
C_{OSS}	Output Capacitance			150	180	
C_{RSS}	Reverse Transfer Capacitance			60	75	
$t_{d(ON)}$	Turn-on Delay Time	$V_{GS} = 15V$ $V_{DD} = 0.5V_{DSS}$ $I_D = I_{D[Cont.]} @ 25^\circ C$ $R_G = 1.6\Omega$		7		ns
t_r	Rise Time			6		
$t_{d(off)}$	Turn-off Delay Time			20		
t_f	Fall Time			4.0	7	

Functional Characteristics

Symbol	Characteristic	Test Conditions	Min	Typ	Max	Unit
G_{PS}	Common Source Amplifier Power Gain	$f = 40.68MHz$ $I_{dq} = 50mA$ $V_{DD} = 125V$ $P_{OUT} = 150W$	13	15		dB
η	Drain Efficiency		70	75		%
Ψ	Electrical Ruggedness VSWR 10:1		No Degradation in Output Power			

1. Pulse Test: Pulse width < 380 μS , Duty Cycle < 2%.

Microsemi reserves the right to change, without notice, the specifications and information contained herein.

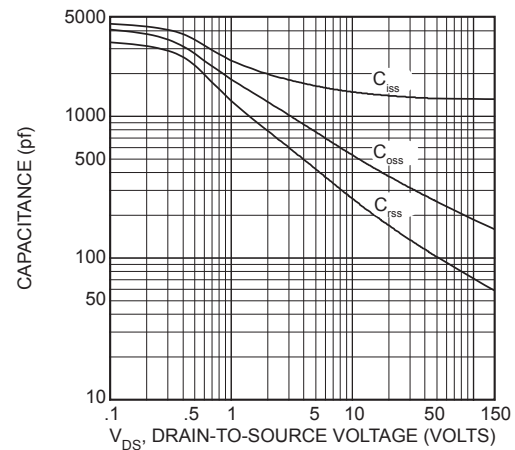

Figure 2, Typical Capacitance vs. Drain-to-Source Voltage

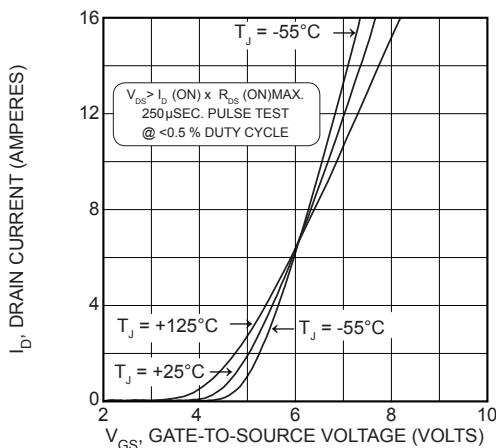

Figure 3, Typical Transfer Characteristics

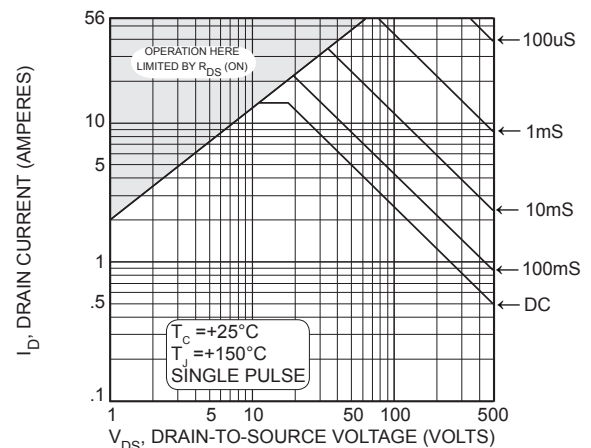

Figure 4, Typical Maximum Safe Operating Area

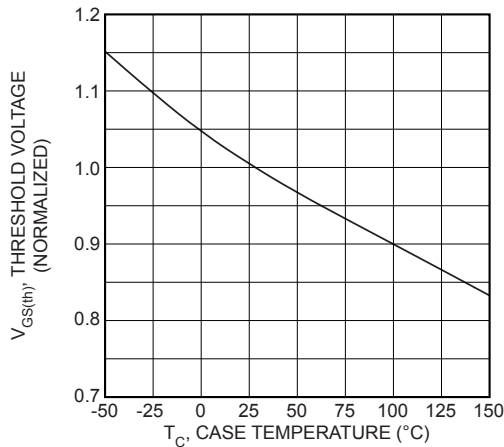

Figure 5, Typical Threshold Voltage vs Temperature

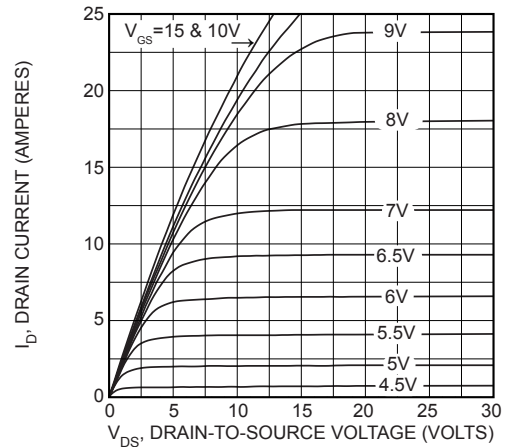

Figure 6, Typical Output Characteristics

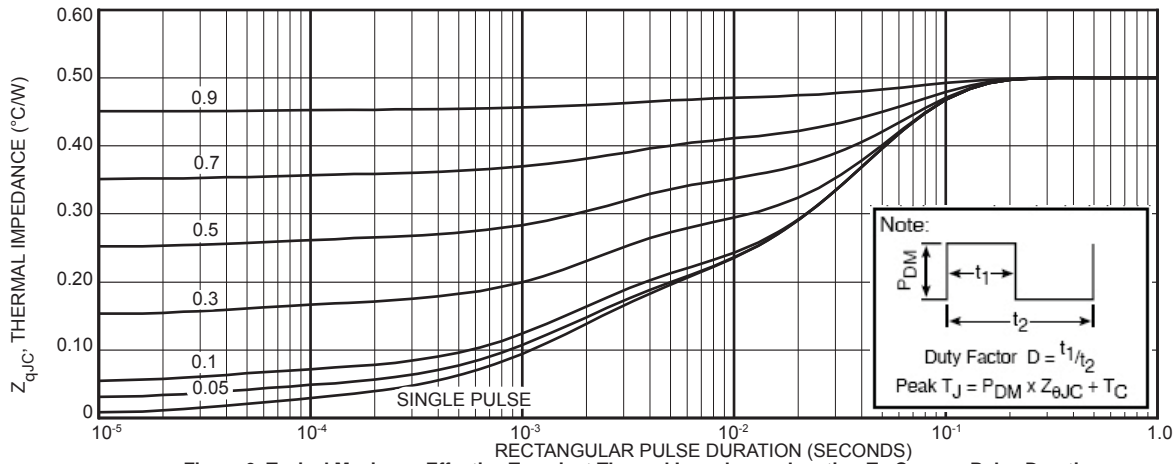

Figure 9, Typical Maximum Effective Transient Thermal Impedance, Junction-To-Case vs Pulse Duration

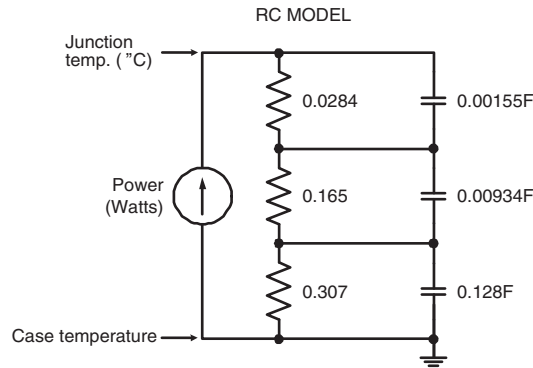
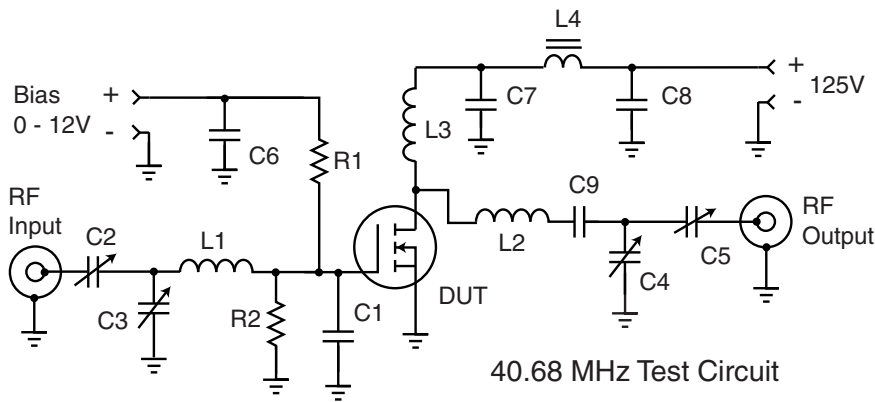

Figure 9a, TRANSIENT THERMAL IMPEDANCE MODEL

Table 1 - Typical Class AB Large Signal Input - Output Impedance

Freq. (MHz)	Z _{in} (Ω)	Z _{OL} (Ω)
2.0	20.9 - j 9.2	38 - j 2.6
13.5	2.4 - j 6.8	31 - j 14
27	.57 - j 2.6	19.6 - j 17.6
40	.31 - j 0.5	12.5 - j 15.8
65	.44 - j 1.9	6.0 - j 10.5

Z_{IN} - Gate shunted with 25Ω I_{dq} = 100mA
 Z_{OL} - Conjugate of optimum load for 150 Watts output at V_{dd}=125V



- C1 -- 2000 pF 100V NPO chip mounted at gate lead
- C2-C5 -- Arco 463 Mica trimmer
- C6-C8 -- .1 μF 500V ceramic chip
- C9 -- 2200 pF 500V chip
- L1 -- 4t #20 AWG .25"ID .3"L ~80nH
- L2 -- 6t #16 AWG .312" ID .4"L ~185nH
- L3 -- 15t #24 AWG .25"ID ~.85uH
- L4 -- VK200-4B ferrite choke 3uH
- R1-R2 -- 51 Ohm 0.5W Carbon
- DUT = ARF460A/B

TO-247 Package Outline

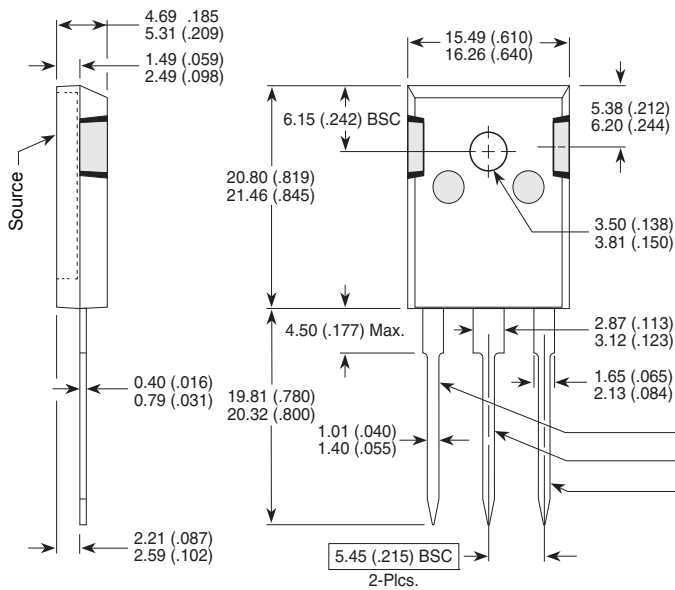

NOTE: These two parts comprise a symmetric pair of RF power transistors and meet the same electrical specifications. The device pin-outs are the mirror image of each other to allow ease of use as a push-pull pair.

Device	
ARF- A	ARF- B

Gate ----- Drain
 Source ---- Source
 Drain ----- Gate

Dimensions in Millimeters and (Inches)

Microsemi's products are covered by one or more of U.S. patents 4,895,810 5,045,903 5,089,434 5,182,234 5,019,522 5,262,336 6,503,786 5,256,583 4,748,103 5,283,202 5,231,474 5,434,095 5,528,058 6,939,743 and foreign patents. US and Foreign patents pending. All Rights Reserved.