

CoolMOS™ 1) Power MOSFET

Low $R_{DS(on)}$, high V_{DSS}
Superjunction MOSFET

$$\begin{aligned} V_{DSS} &= 600 \text{ V} \\ I_{D25} &= 85 \text{ A} \\ R_{DS(on) \text{ max}} &= 36 \text{ m}\Omega \end{aligned}$$

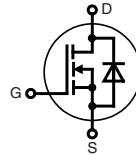

TO-264

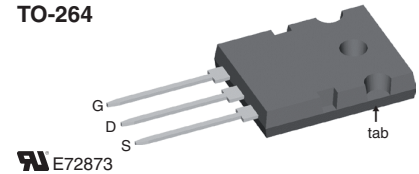

MOSFET			
Symbol	Conditions	Maximum Ratings	
V_{DSS}	$T_{VJ} = 25^\circ\text{C}$	600	V
V_{GS}		± 20	V
I_{D25}	$T_C = 25^\circ\text{C}$	85	A
I_{D100}	$T_C = 100^\circ\text{C}$	55	A
E_{AS}	single pulse $I_D = 10 \text{ A}; T_C = 25^\circ\text{C}$	1800	mJ
E_{AR}	repetitive $I_D = 20 \text{ A}; T_C = 25^\circ\text{C}$	1	mJ
dV/dt	MOSFET dV/dt ruggedness $V_{DS} = 0 \dots 480 \text{ V}$	50	V/ns

Features

- 3rd generation CoolMOS™ 1) power MOSFET
- high blocking capability
- lowest resistance
- avalanche rated for unclamped inductive switching (UIS)
- low thermal resistance due to reduced chip thickness

Applications

- Switched mode power supplies (SMPS)
- Uninterruptible power supplies (UPS)
- Power factor correction (PFC)
- Welding
- Inductive heating

Symbol	Conditions	Characteristic Values			
		$(T_{VJ} = 25^\circ\text{C}, \text{ unless otherwise specified})$			
		min.	typ.	max.	
$R_{DS(on)}$	$V_{GS} = 10 \text{ V}; I_D = I_{D100}^{\text{①}}$		30	36	m Ω
$V_{GS(th)}$	$V_{DS} = V_{GS}; I_D = 5.4 \text{ mA}$	2		4	V
I_{DSS}	$V_{DS} = V_{DSS}; V_{GS} = 0 \text{ V}$			50	μA
	$T_{VJ} = 25^\circ\text{C}$			500	μA
	$T_{VJ} = 125^\circ\text{C}$				
I_{GSS}	$V_{GS} = \pm 20 \text{ V}; V_{DS} = 0 \text{ V}$			± 200	nA
C_{iss}	} $V_{GS} = 0 \text{ V}; V_{DS} = 25 \text{ V}$ $f = 1 \text{ MHz}$		13.6		nF
C_{oss}			4.4		nF
C_{rss}			290		pF
Q_g	} $V_{GS} = 0 \text{ to } 10 \text{ V}; V_{DS} = 350 \text{ V}; I_D = 85 \text{ A}$		500	640	nC
Q_{gs}			50		nC
Q_{gd}			240		nC
$t_{d(on)}$	} $V_{GS} = 13 \text{ V}; V_{DS} = 380 \text{ V}$ $I_D = 85 \text{ A}; R_G = 1.0 \Omega$		20		ns
t_r			27		ns
$t_{d(off)}$			110		ns
t_f			10		ns
R_{thJC}				0.18	K/W

① Pulse test, $t \leq 300 \mu\text{s}$, duty cycle $d \leq 2\%$

¹⁾ CoolMOS™ is a trademark of Infineon Technologies AG.

Source-Drain Diode

Symbol	Conditions	Characteristic Values			
		min.	typ.	max.	
($T_{VJ} = 25^{\circ}\text{C}$, unless otherwise specified)					
I_S	$V_{GS} = 0\text{ V}$			85	A
I_{SM}				250	A
V_{SD}	$I_F = 85\text{ A}; V_{GS} = 0\text{ V}$			1.2	V
t_{rr}	$I_F = 85\text{ A}; -di_F/dt = 200\text{ A}/\mu\text{s}; V_R = 350\text{ V}$		580		ns
Q_{RM}			46		μC
I_{RM}			140		A

Component

Symbol	Conditions	Maximum Ratings		
		min.	typ.	max.
T_{VJ}	operating		-55...+150	$^{\circ}\text{C}$
T_{stg}			-55...+150	$^{\circ}\text{C}$
M_d	mounting torque		0.8 ... 1.2	Nm

Symbol	Conditions	Characteristic Values		
		min.	typ.	max.
R_{thCH}	with heatsink compound		0.15	K/W
Weight			10	g

TO-264 Outline

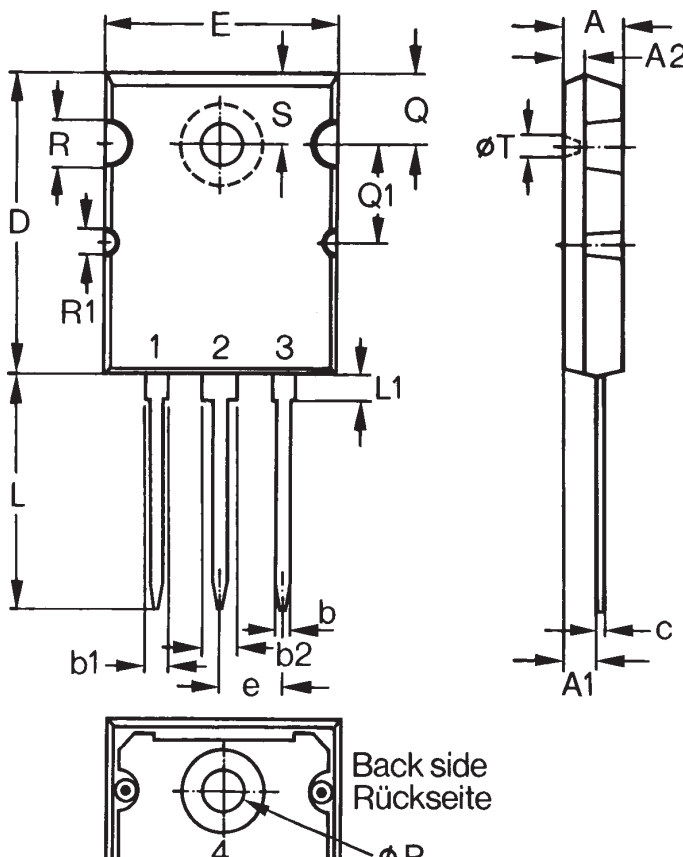

SYM	INCHES		MILLIMETERS	
	MIN	MAX	MIN	MAX
A	.185	.209	4.70	5.31
A1	.102	.118	2.59	3.00
b	.037	.055	0.94	1.40
b1	.087	.102	2.21	2.59
b2	.110	.126	2.79	3.20
C	.017	.029	0.43	0.74
D	1.007	1.047	25.58	26.59
E	.760	.799	19.30	20.29
e	.215 BSC		5.46 BSC	
L	.193	.201	4.90	5.10
L1	.088	.096	2.24	2.44
L2	.075	.083	1.90	2.10
L3	.000	.004	0.00	0.10
ØP	.122	.138	3.10	3.51
Q	.240	.256	6.10	6.50
Q1	.330	.346	8.38	8.79
ØR	.155	.187	3.94	4.75
ØR1	.085	.093	2.16	2.36
S	.243	.253	6.17	6.43

- NOTE 1. This drawing meets all dimension requirement of JEDEC outline TO-264A except L, L1, L2, L3
2. All metal surface are solder patted except trimmed area

IXYS reserves the right to change limits, test conditions and dimensions.

20100315c

**Fig. 1. Output Characteristics
@ 25 Deg. C**

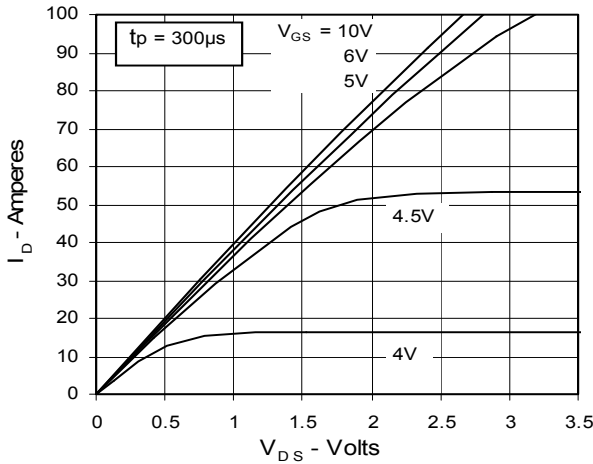

**Fig. 2. Extended Output Characteristics
@ 25 deg. C**

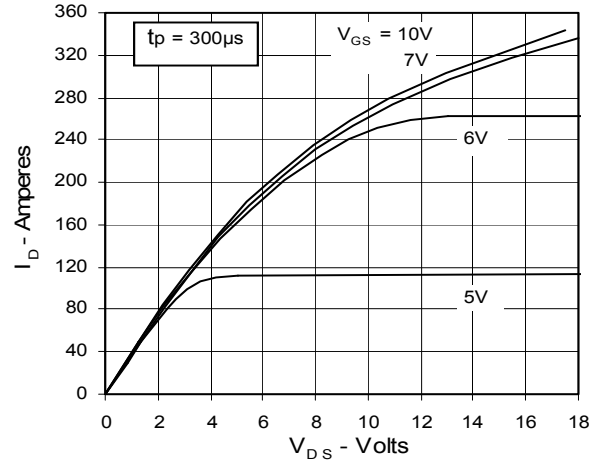

**Fig. 3. Output Characteristics
@ 125 Deg. C**

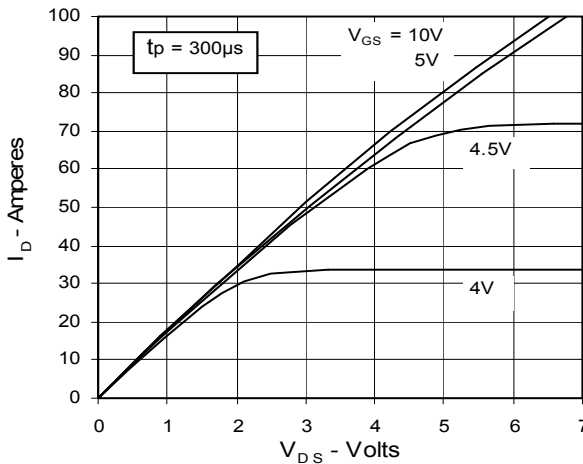

**Fig. 4. R_DS(on) Normalized to I_D100 Value
vs. Junction Temperature**

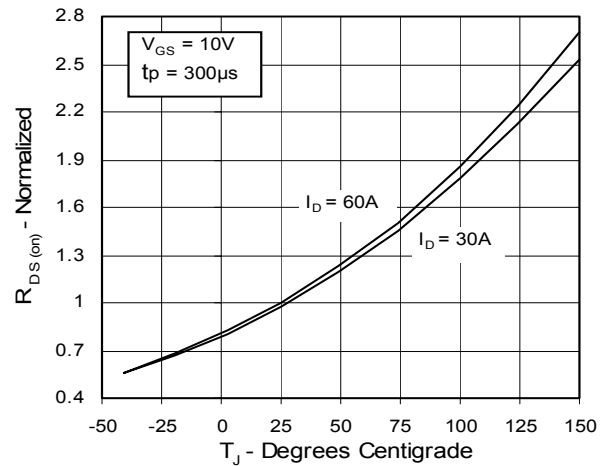

**Fig. 5. R_DS(on) Normalized to
I_D100 Value vs. I_D**

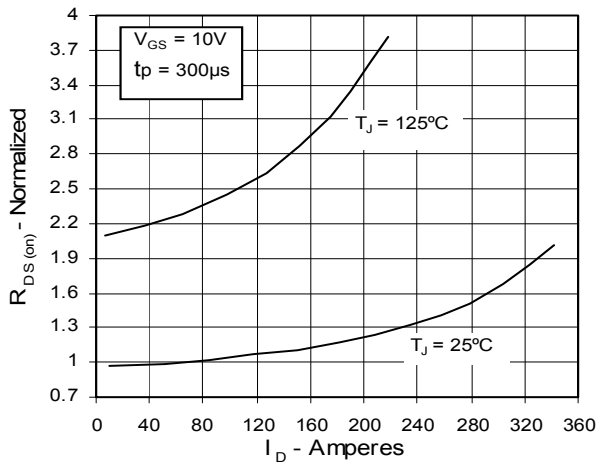

**Fig. 6. Drain Current vs. Case
Temperature**

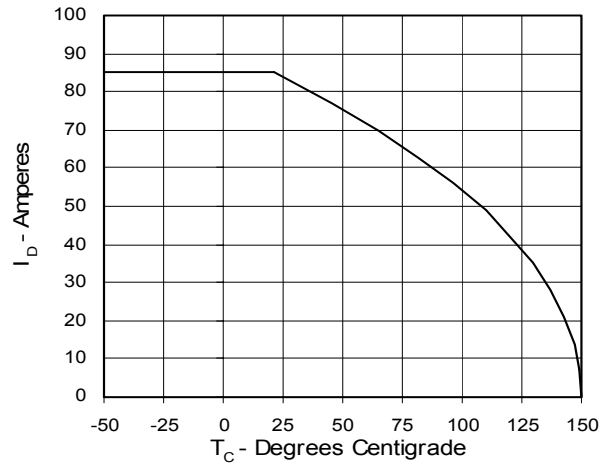

Fig. 7. Input Admittance

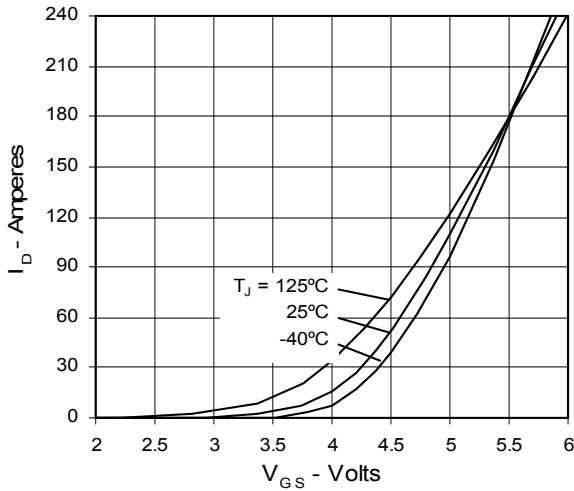

Fig. 8. Transconductance

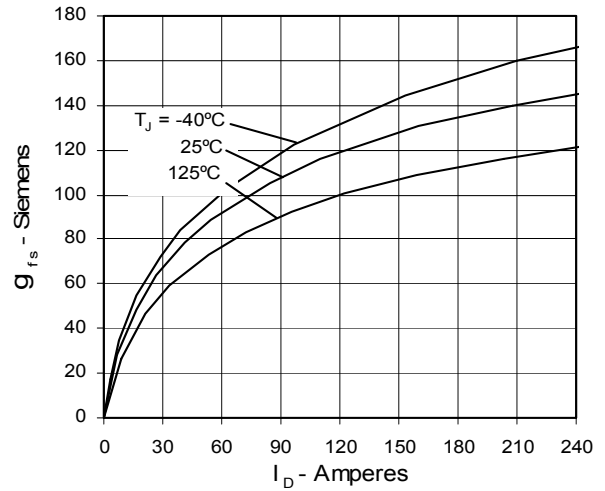

Fig. 9. Source Current vs. Source-To-Drain Voltage

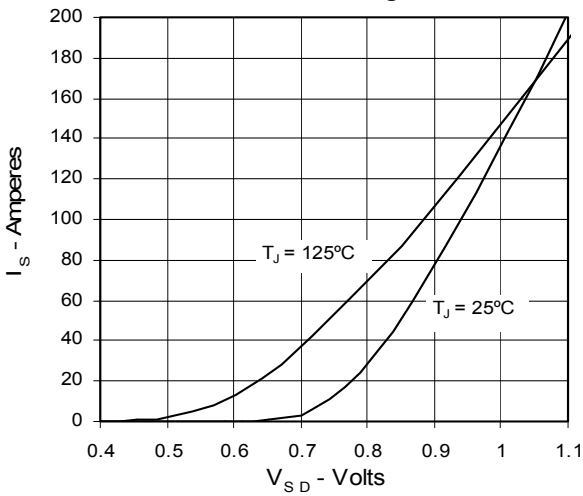

Fig. 10. Gate Charge

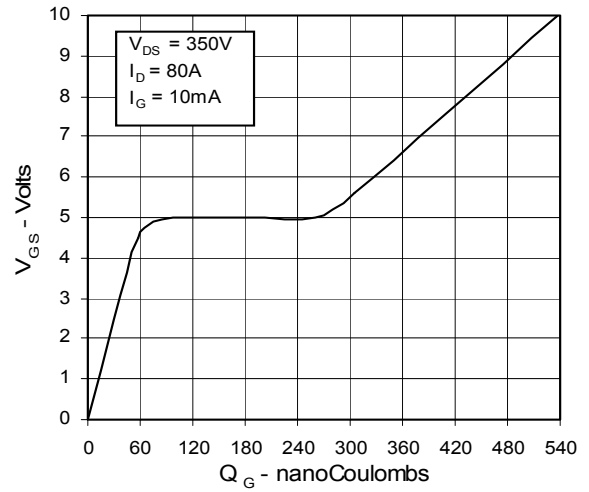

Fig. 11. Capacitance

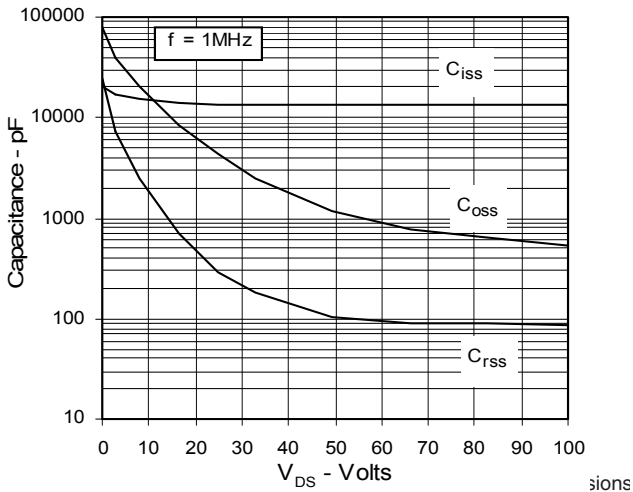

Fig. 12. Maximum Transient Thermal Resistance

