

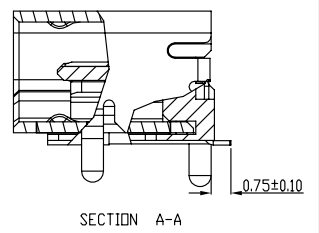

Copyright FCI.

PRODUCT NO.
10029449-X01XLF

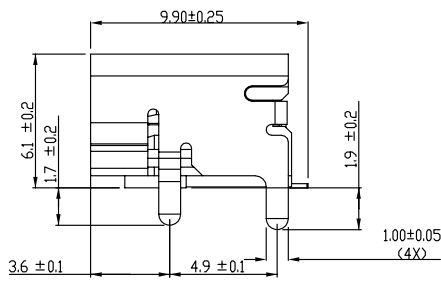
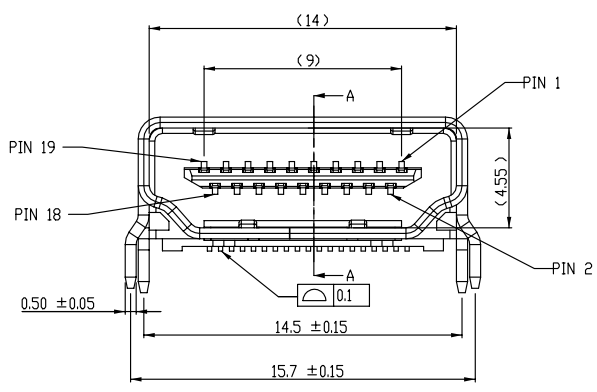
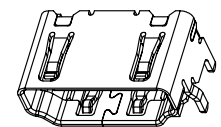
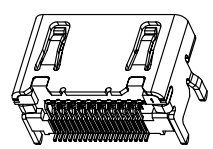
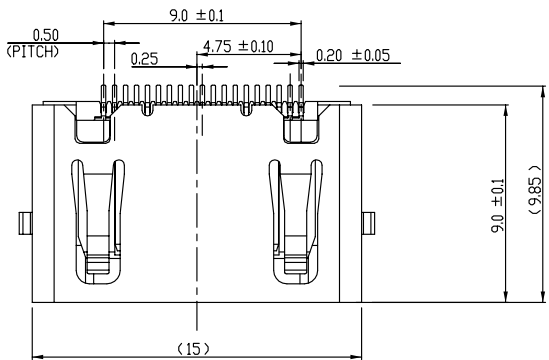

www.fciconnect.com				surface 6.4 Iso 1302	tolerance std Iso406 Iso 1101	projection MM	
				ANGULAR	LINEAR	0.X ± 0.3 0.XX ± 0.15 0.XXX ± 0.05	size A4 Scale 4.000
				0° ± 2°		ECN N10-0201	Spec ref N10-0201
Dr	LEIF SHEN	10/15/04					
Eng	LEIF SHEN	10/15/04					
Chr	PAUL WANG	10/15/04					
Appr	JOSEPH HSIA	10/15/04					
rev	ecn no	dr	date	Product family HDMI		Spec ref	
M	N09-0307	SH	10/21/09				
N	N10-0033	SH	02/01/10				
P	N10-0201	KW	2011-02-14				
				title HDMI TYPE A RECEPTACLE		Rev. P	
				HDMI		10029449	
				catalog no		CUSTOMER sheet 1 of 5	

REV P - 2011-02-14

3 PDM: Rev:P STATUS Released 4 Printed: Apr 16, 2011



Copyright FCI.

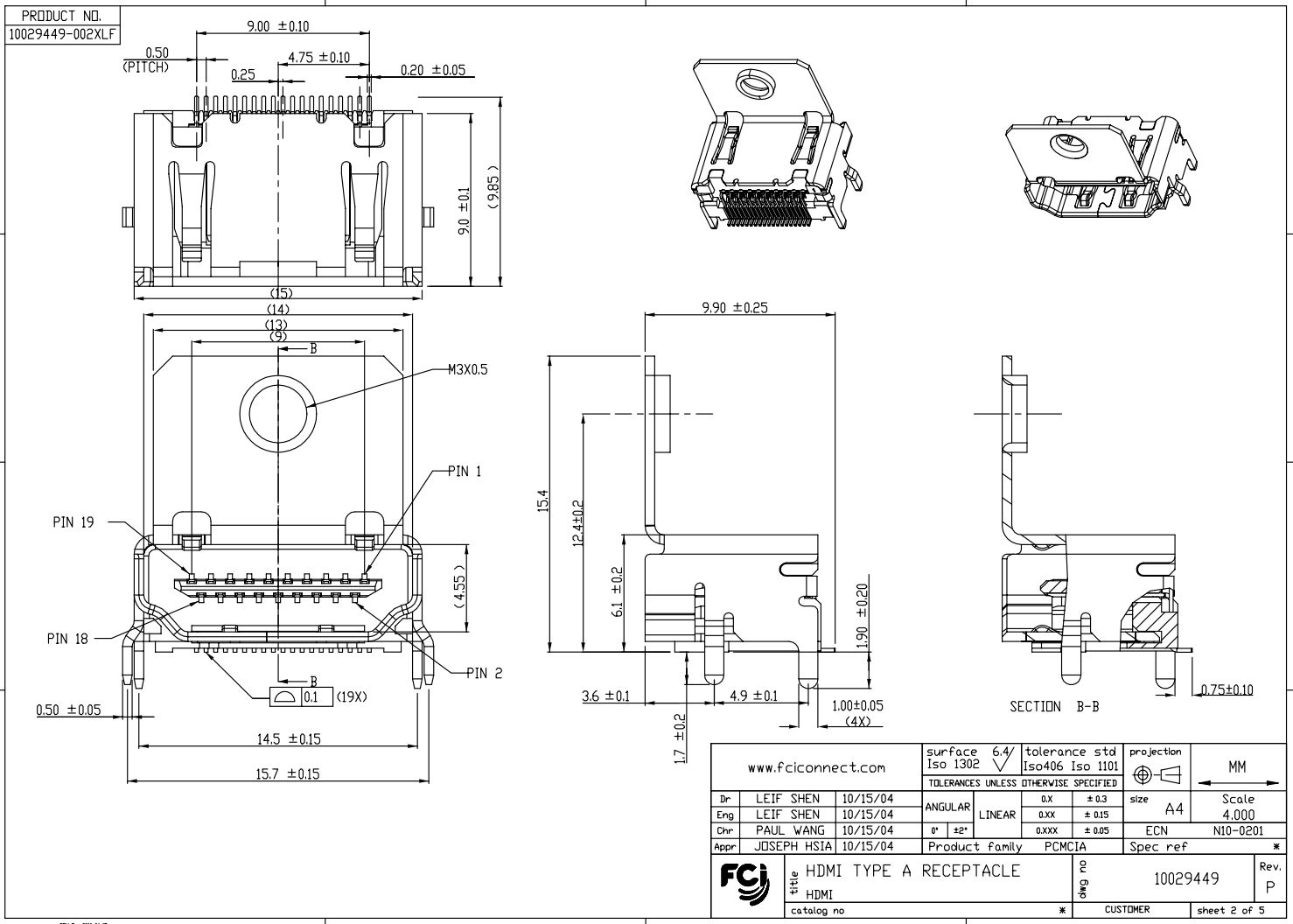

www.fciconnect.com		surface 6.4/	tolerance std	projection	MM
		Iso 1302	Iso406 Iso 1101		Scale
		TOLERANCES UNLESS OTHERWISE SPECIFIED		size A4	4.000
Dr	LEIF SHEN 10/15/04	ANGULAR	LINEAR	0.X ±0.3	ECN N10-0201
Eng	LEIF SHEN 10/15/04	0° ±2*		0.XX ±0.15	
Chr	PAUL WANG 10/15/04			0.XXX ±0.05	
Appr	JOSEPH HSIA 10/15/04	Product family	PCMCIA	Spec ref	
		title HDMI TYPE A RECEPTACLE		10029449	Rev. P
catalog no		CUSTOMER		sheet 2 of 5	

3PDM: Rev:P STATUS Released 4 Printed: Apr 16, 2011

PRODUCT NO.	CONTACT AREA PLATING	SHIELD FIGURE	PACKING
10029449-001TLF	30u" Au MINIMUM	WITHOUT FLANGE	TRAY
10029449-001RLF	30u" Au MINIMUM	WITHOUT FLANGE	TAPE AND REEL
10029449-101TLF	GOLD FLASH	WITHOUT FLANGE	TRAY
10029449-101RLF	GOLD FLASH	WITHOUT FLANGE	TAPE AND REEL
10029449-002TLF	30u" Au MINIMUM	WITH FLANGE	TRAY
10029449-002RLF	30u" Au MINIMUM	WITH FLANGE	TAPE AND REEL
10029449-002FLF	GOLD FLASH	WITH FLANGE	TAPE AND REEL

NOTES:

- MATERIAL
 - 1-1 HOUSING: GLASS FIBER HIGH-TEMP. RESIN.(UL94V-0)
 - 1-2 CONTACT: BRASS
 - 1-3 SHELL : STEEL
- FINISH
 - 2-1 CONTACT : Ni UNDER PLATED ALL OVER 50u" MIN CONTACT AREA SEE TABLE
 - 2-2 SHELL : Ni 100u" MIN.
- PACKAGING:
 - PACKAGING SPECIFICATION GS-14-939.
- RoHS STANDARD SPECIFICATION ACCORDING TO FCI GS-22-008.
- PARTS MEET REFLOW APPLICATION PEAK TEM. 260 DEGREE C, 10 SECONDS MAX.
- PRODUCT SPECIFICATION: GS-12-309

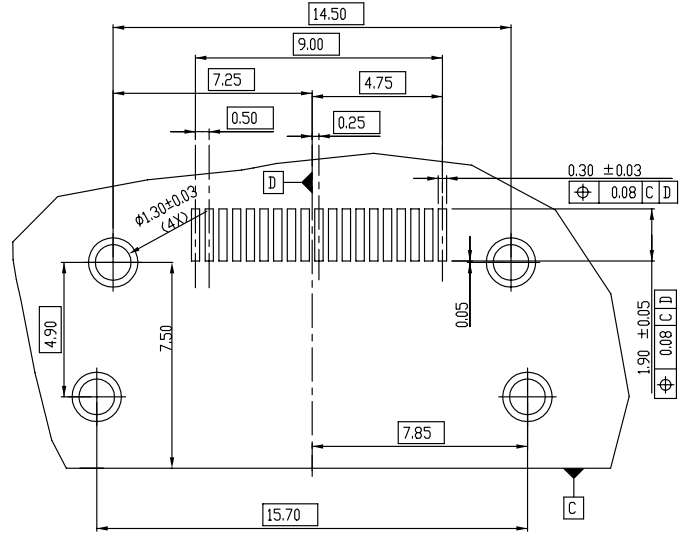

RECOMMENDED PCB PATTERN LAYOUT
(t=1.6mm)

www.fciconnect.com			surface Iso 1302	6.4	tolerance std Iso406 Iso 1101	projection Iso 1101	MM
			TOLERANCES UNLESS OTHERWISE SPECIFIED				
Dr	LEIF SHEN	10/15/04	ANGULAR	LINEAR	0.X 0.XX 0.XXX	± 0.3 ± 0.15 ± 0.05	size A4 Scale 5.000
Eng	LEIF SHEN	10/15/04	0°	±2°			ECN N10-0201
Chr	PAUL WANG	10/15/04					
Appr	JOSEPH HSIA	10/15/04	Product family		PCMCIA	Spec ref	
FCI			title			10029449	
			HDMI TYPE A RECEPTACLE			Rev. P	
			catalog no			CUSTOMER sheet 3 of 5	

REV P - 2009-07

3 PDM: Rev:P

4 STATUS Released Printed: Apr 16, 2011

1	2	3	4
PRODUCT NO.	CONTACT AREA PLATING	SHIELD FIGURE	PACKING
10029449-111RLF	GOLD FLASH	WITHOUT FLANGE	TAPE AND REEL

NOTE:
 1.MATERIAL:
 HOUSING: HIGH TEMP.THERMOPLASTIC, UL 94V-0
 COLOR: BLACK.
 CONTACT: PHOSPHOR BRONZE
 SHIELD: BRASS
 2.FINISH:
 CONTACT: SEE THE TABLE
 SHIELD: Ni 50u" MIN.
 3.TERMINAL RETENTION FORCE TO BE 0.3kgf MIN.

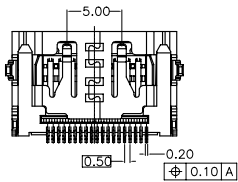
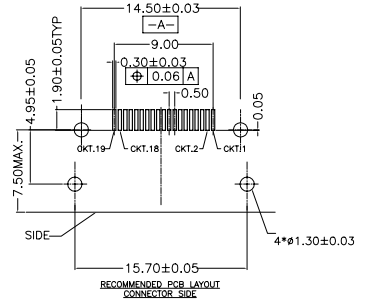
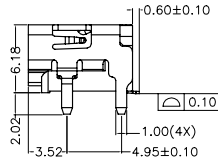
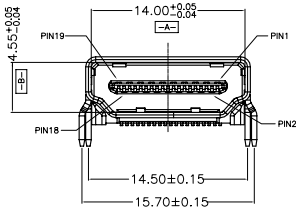
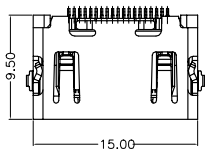

www.fciconnect.com		surface 6/4 Iso 1302	tolerance std Iso406 Iso 1101	projection MM	MM
TOLERANCES UNLESS OTHERWISE SPECIFIED		ANGULAR	LINEAR	size A4	Scale 2,000
Dr	LEIF SHEN 10/15/04	0° ±2°	0.X ±0.3 0.XX ±0.15 0.XXX ±0.05	ECN	N10-0201
Eng	LEIF SHEN 10/15/04	Product family	HDMI	Spec ref	
Chr	PAUL WANG 10/15/04				
Appr	JOSEPH HSIA 10/15/04				
FCI title HDMI TYPE A RECEPTACLE		Rev. P	10029449	Rev. P	
catalog no		CUSTOMER		sheet 4 of 5	

REV 7 - 2004-07

3PDM: Rev:P STATUS Released 4 Printed: Apr 16, 2011



Copyright FCI.



Copyright FCI.

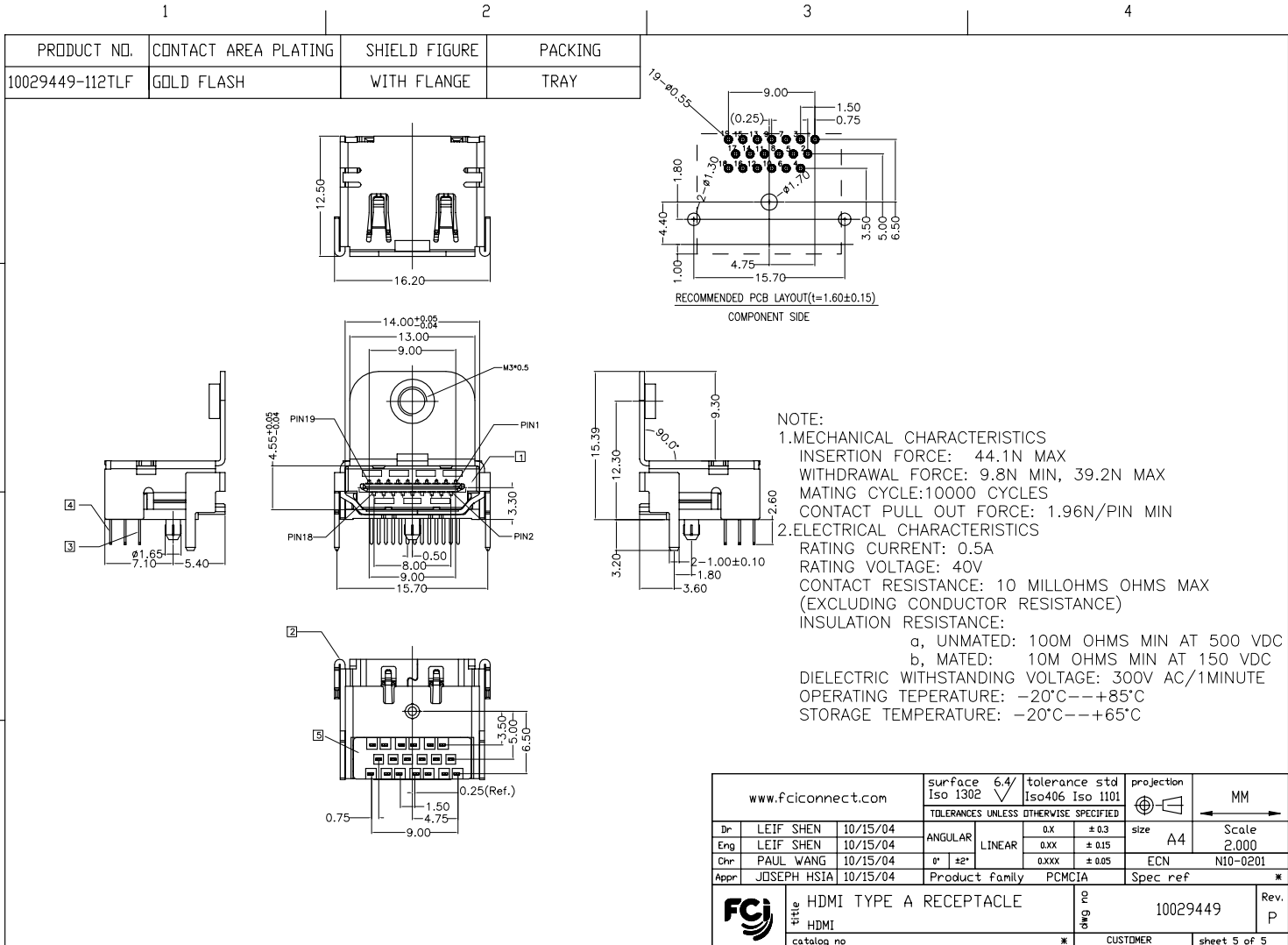

www.fciconnect.com			surface 6/4 Iso 1302	tolerance std Iso406 Iso 1101	projection MM
TOLERANCES UNLESS OTHERWISE SPECIFIED			ANGULAR	LINEAR	size A4
Dr	LEIF SHEN	10/15/04	0° ±2°	0.X 0.XX 0.XXX	Scale 2,000
Eng	LEIF SHEN	10/15/04		±0.3 ±0.15 ±0.05	ECN N10-0201
Chr	PAUL WANG	10/15/04			
Appr	JOSEPH HSIA	10/15/04	Product family	PCMCIA	Spec ref
		title HDMI TYPE A RECEPTACLE		10029449	Rev. P
catalog no		CUSTOMER		sheet 5 of 5	

REV 1 - 2004-07