

THIS DOCUMENT IS THE PROPERTY OF KEYSTONE ELECTRONICS CORP. AND SHALL NOT BE REPRODUCED, DISTRIBUTED OR USED AS A BASIS FOR MANUFACTURE WITHOUT PRIOR WRITTEN PERMISSION FROM KEYSTONE ELECTRONICS CORP.

**MOUNTING DETAIL**

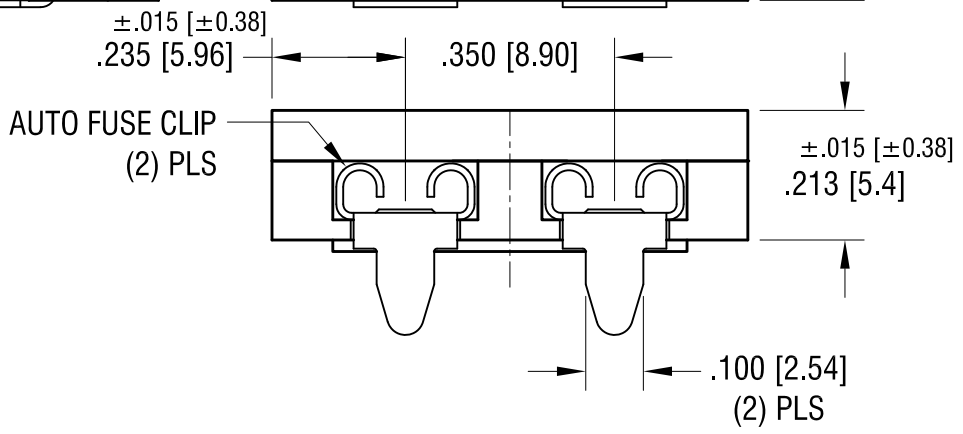
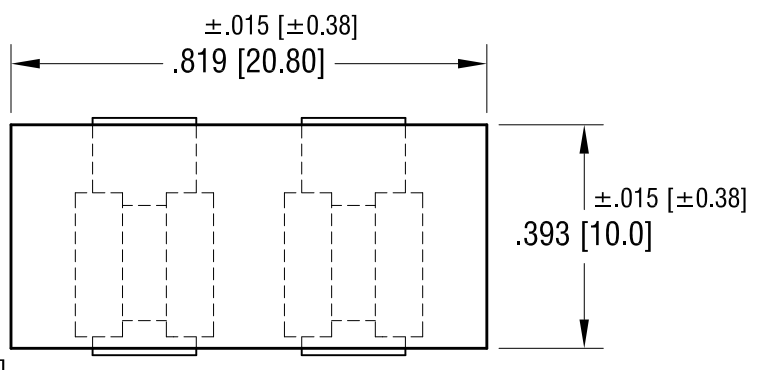
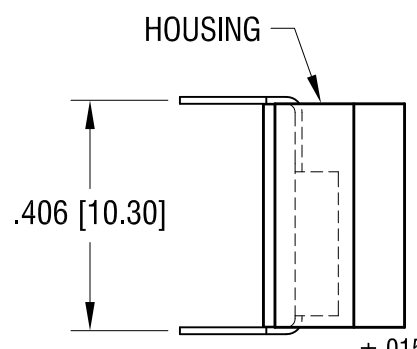
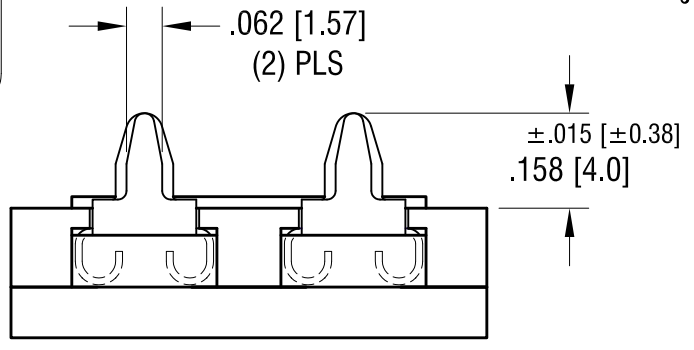
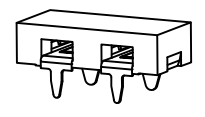
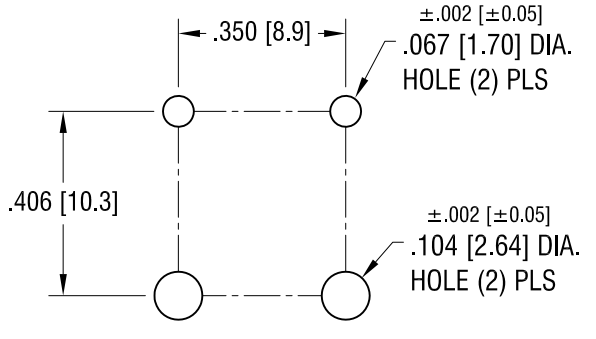

**NOTE:**  
 CLIP: MAT'L: .012 [0.30] TH'K BRASS, NICKEL PLATE  
 HOUSING: MAT'L: PBT, UL 94V-0

<b>KEYSTONE ELECTRONICS CORP.</b>			
www.keyelco.com • ASTORIA, N.Y. 11105-2017 • Tel (718) 956-8900			
PART NAME			
HOR. STANDARD AUTO-BLADE FUSE HOLDER			
MATERIAL			
AS NOTED			
FINISH		DRN BY	DATE
AS NOTED		BOONE	12.28.06
		APP'D	SCALE
			3X
TOLERANCES	INCH [MM]	CODE	DWG NO.
DECIMAL	± .005 [± 0.15]	C/M	<b>3550-2</b>
ANGULAR	± 1°		
UNLESS OTHERWISE SPECIFIED			

9.24.08	CHANGE AS PER ECN 08-164	A
DATE	DESCRIPTION	REV.