

.250 (6.4) DIAMETER FUSE CLIPS

Refer to pages 38-40 for Fuse Clip Layout and Mounting Details

For 1AG, 3AG, 7AG, 8AG THRU HOLE MOUNT TYPES

WITH SNAP-IN PC LEGS



MATERIAL:
.020 (.51) thick Brass, Tin Plate
Current Rating: 15 Amps

CAT. NO. 3513

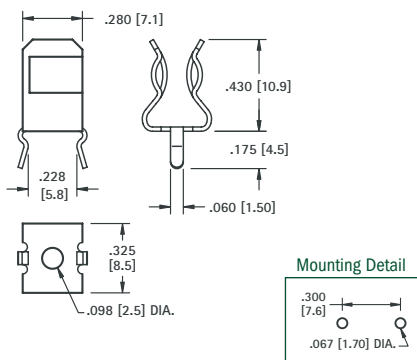

WITH SNAP-IN PC LEGS

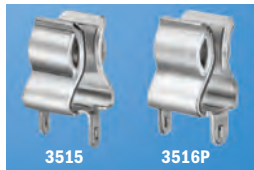

MATERIAL:
.020 (.51) thick Brass, Tin Plate
Current Rating: 15 Amps

CAT. NO.	A	B
3515	.060 (1.5)	.060 (1.5)
3515P	.060 (1.5)	.093 (2.4)
3516P	.060 (1.5)	.120 (3.0)

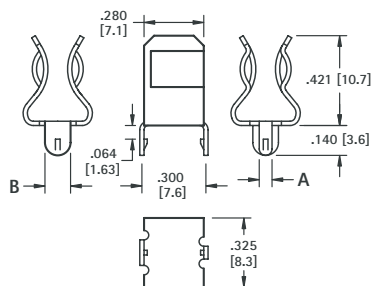

With or Without Orientation Legs

WITH STRAIGHT PC LEGS



MATERIAL:
.020 (.51) thick Brass, Tin Plate
Current Rating: 15 Amps

CAT. NO. 3530

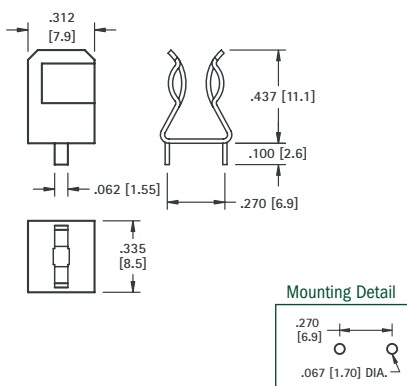

WITH STRAIGHT PC LEGS



MATERIAL:
.020 (.51) thick Brass, Tin Plate
Current Rating: 15 Amps

CAT. NO.	H	L	END STOPS
3510	.421 (10.7)	.140 (3.6)	NO
3529	.421 (10.7)	.140 (3.6)	YES
3511	.430 (10.9)	.250 (6.4)	NO
3514	.430 (10.9)	.250 (6.4)	YES

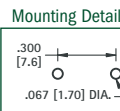
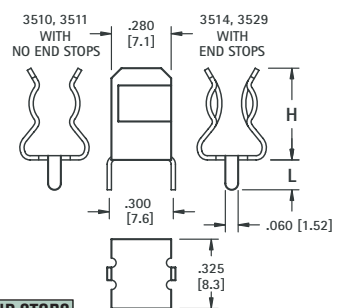

WITH SOLDER LUG



MATERIAL:
.020 (.51) thick Brass, Nickel Plate
Current Rating: 15 Amps

CAT. NO.	A	B
3533	Flat	.656 (16.7)
3535	45°	.562 (14.3)
3570	-	NO TAB

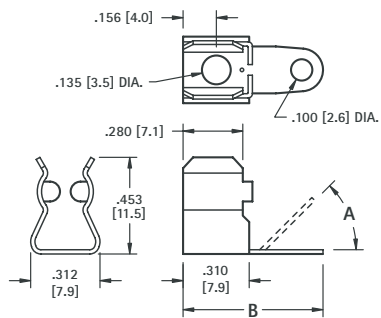

For 1AG, 3AG, 7AG, 8AG RIVET & SURFACE MOUNT TYPES

LOW PROFILE



MATERIAL:
.020 (.51) thick Brass, Nickel Plate
Current Rating: 15 Amps

CAT. NO. 3531 (Without End Stops)

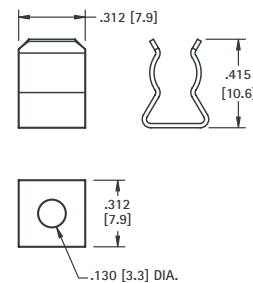

WITH QUICK-FIT TAB



MATERIAL:
.020 (.51) thick Brass, Nickel Plate
Current Rating: 15 Amps

CAT. NO.	A	B
4246	.020 (0.5)	.187 (4.7)
4247	.020 (0.5)	.205 (5.2)
4244	.032 (0.8)	.250 (6.4)

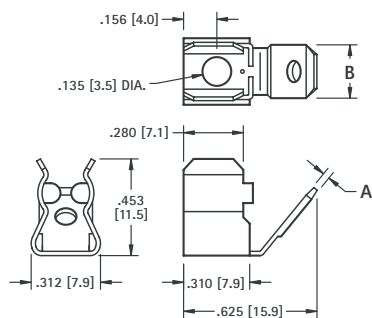

WITH OR WITHOUT END STOPS



MATERIAL:
.020 (.51) thick Brass, Nickel Plate
Current Rating: 15 Amps

CAT. NO.	END STOPS
3532	YES
3567	NO

