

# .250 (6.4) DIAMETER FUSE CLIPS

Refer to pages 38-40 for Fuse Clip Layout and Mounting Details

## For 1AG, 3AG, 7AG, 8AG THRU HOLE MOUNT TYPES

### WITH SNAP-IN PC LEGS



**MATERIAL:**  
.020 (.51) thick Brass, Tin Plate  
**Current Rating:** 15 Amps

**CAT. NO. 3513**

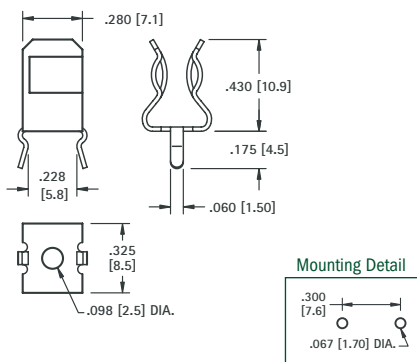

### WITH SNAP-IN PC LEGS

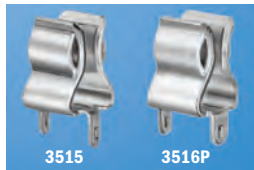

**MATERIAL:**  
.020 (.51) thick Brass, Tin Plate  
**Current Rating:** 15 Amps

CAT. NO.	A	B
<b>3515</b>	.060 (1.5)	.060 (1.5)
<b>3515P</b>	.060 (1.5)	.093 (2.4)
<b>3516P</b>	.060 (1.5)	.120 (3.0)

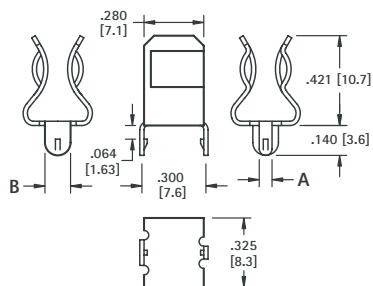

With or Without Orientation Legs

### WITH STRAIGHT PC LEGS



**MATERIAL:**  
.020 (.51) thick Brass, Tin Plate  
**Current Rating:** 15 Amps

**CAT. NO. 3530**

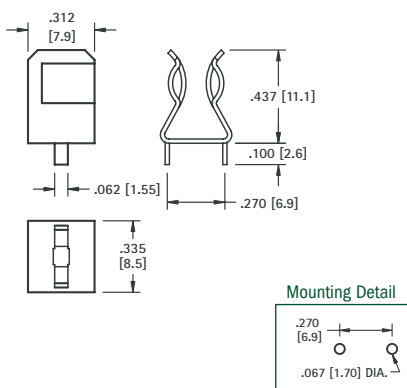

### WITH STRAIGHT PC LEGS



**MATERIAL:**  
.020 (.51) thick Brass, Tin Plate  
**Current Rating:** 15 Amps

CAT. NO.	H	L	END STOPS
<b>3510</b>	.421 (10.7)	.140 (3.6)	NO
<b>3529</b>	.421 (10.7)	.140 (3.6)	YES
<b>3511</b>	.430 (10.9)	.250 (6.4)	NO
<b>3514</b>	.430 (10.9)	.250 (6.4)	YES

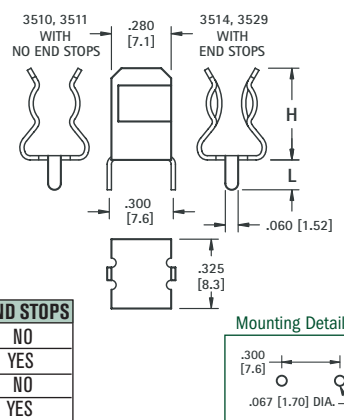

### WITH SOLDER LUG



**MATERIAL:**  
.020 (.51) thick Brass, Nickel Plate  
**Current Rating:** 15 Amps

CAT. NO.	A	B
<b>3533</b>	Flat	.656 (16.7)
<b>3535</b>	45°	.562 (14.3)
<b>3570</b>	-	NO TAB

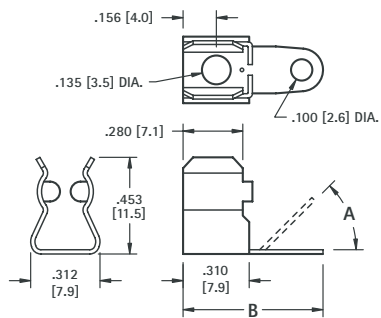

## For 1AG, 3AG, 7AG, 8AG RIVET & SURFACE MOUNT TYPES

### LOW PROFILE



**MATERIAL:**  
.020 (.51) thick Brass, Nickel Plate  
**Current Rating:** 15 Amps

**CAT. NO. 3531** (Without End Stops)

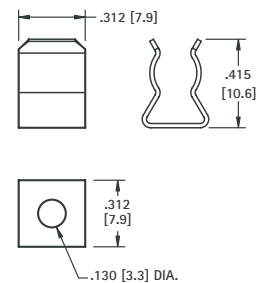

### WITH QUICK-FIT TAB



**MATERIAL:**  
.020 (.51) thick Brass, Nickel Plate  
**Current Rating:** 15 Amps

CAT. NO.	A	B
<b>4246</b>	.020 (0.5)	.187 (4.7)
<b>4247</b>	.020 (0.5)	.205 (5.2)
<b>4244</b>	.032 (0.8)	.250 (6.4)

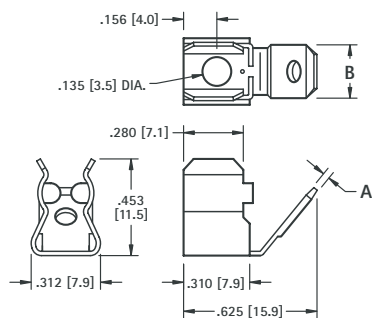

### WITH OR WITHOUT END STOPS



**MATERIAL:**  
.020 (.51) thick Brass, Nickel Plate  
**Current Rating:** 15 Amps

CAT. NO.	END STOPS
<b>3532</b>	YES
<b>3567</b>	NO

