



W54 series

Push To Reset Only P&B Thermal Circuit Breaker



Features

- 5 to 40 amp ratings.
- Cannot be manually tripped.
- Button extends for visual trip indication.
- Push button to reset breaker.
- Numerous mounting and termination options.
- Choice of silver-cadmium oxide or silver-tin oxide contacts.
- Optional bottom marking of amperage rating.

Agency Approvals

W54 series is UL 1077 Recognized as Supplementary Protectors, File E69543, for Canada and the United States. Available models meet Ignition Protection requirements in accordance with UL 1500 (excludes models rated >30A). CSA Accepted as Supplementary Protectors (Appliance Component Protectors), File 240027 (to 125VAC, excludes models rated >30A). Approved to VDE 0642/EN60934 (Circuit Breakers for Equipment) License Number 40007877 (excludes models rated >20A, models with screw terminals, models with silver-tin oxide contacts). CCC mark compliant, certificate 2004010307123217.

Users should thoroughly review the technical data before selecting a product part number. It is recommended that users also seek out the pertinent approvals files of the agencies/laboratories and review them to confirm the product meets the requirements for a given application.

Electrical Data @ 25°C

Calibration: Will continuously carry 100% of rating.
May trip between 101% and 134%, but must trip at 135% of rating within one hour at +25°C.

Dielectric Strength: 1,500VAC (60 seconds).

Insulation Resistance: 100 megohms.
Maximum Operating Voltages: 50VDC; 250VAC.
Interrupt Capacity: 1,000 amps in accordance with UL standard 1077.
Resettable Overload Capacity: Ten times rated current.
Reset Time: 60 seconds.

Typical Resistance vs. Current Rating @25°C

Current Rating in Amps	Typical Resistance in Ohms	Current Rating in Amps	Typical Resistance in Ohms
5.0	0.050	15.0	0.017
6.0	0.042	20.0	0.012
7.0	0.036	25.0	0.010
8.0	0.031	30.0	0.008
10.0	0.025	35.0	0.007
12.0	0.021	40.0	0.006

Mechanical/Environmental Data

Operating Temperature Range: 0°C to +60°C.
Termination: .250" (6.35mm) quick connects or #8-32 screws.
Mounting: Various options. See Ordering Information and drawings.
Approximate Weight: 0.9 oz. (25.0g).

Time vs. Current Trip Curve @ +25°C

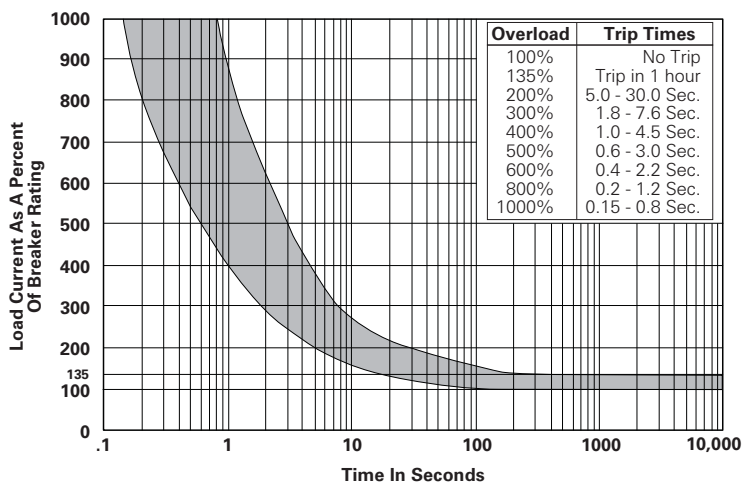

Ambient Compensation Table

Ambient Temperature in °C	Rating Correction Factor	
	5-8A Models	9-30A Models
10	.90	.80
20	.98	.90
25	1.00	1.00
30	1.10	1.05
40	1.25	1.15
50	1.61	1.31
60	2.00	1.55

To use this chart: Divide the breaker rating by the correction factor to determine the compensated rating. Calculate the overloads in terms of the compensated rating to use the published trip curve. Do not use these devices outside their specified operating temperature ranges.

Outline Dimensions

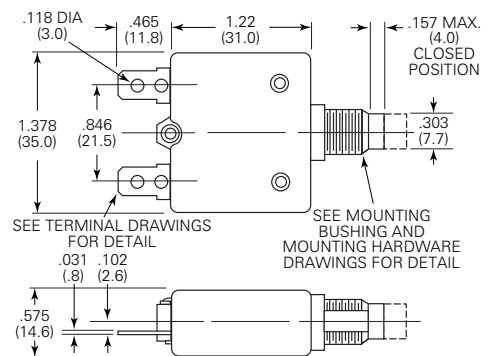

Optional Protective Boot

Silicone rubber boot is bonded to integral aluminum nut.

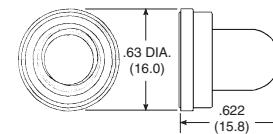

1-1423696-5
Black boot for W54 with 3/8"-24 bushing.

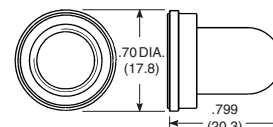

1-1423696-6
Clear boot for W54 with M11 X 1.0 bushing.

Ordering Information

Typical Part No. >	W	54	-X	B	1	A	4	A	1	0	-5
1. Designator: W = Circuit breaker											
2. Series Number: 54 = Single pole, push-to-reset, thermal model											
3. Circuit Function & Contact Material: X = Series trip, silver-cadmium oxide contacts F = Series trip, silver-tin oxide contacts † †Not VDE											
4. Button Color & Rate Marking: A = White, plain, no rate marking B = White with red rate marking (vertical) C = White with black rate marking (vertical) D = Black, plain, no rate marking E = Black with white rate marking (horizontal) F = White with red rate marking (horizontal) G = White with black rate marking (horizontal) H = Black with white rate marking (vertical) I = Red, plain, no rate marking J = Black, no rate marking on button, white rate marking on bottom of case between terminals.											
5. Mounting Bushing: 1 = Metal, 9.8mm (double D) x 12.6mm long, M11x1 threads, (similar to 7/16"), round base 2 = Metal, 3/8" (single D) x 10mm long, 3/8"x24 threads, hex base 3 = Metal, 9.8mm (double D) x 12.6mm long, M11x1 threads, (similar to 7/16"), hex base 4 = Metal, 10.5mm (double D) x 12.6mm long, M12x1 threads, (similar to 15/32"), round base 6 = Plastic, 9.8mm (double D) x 12.6mm long, M11x1 threads, (similar to 7/16"), round base 7 = Plastic, 3/8" (single D) x 10mm long, 3/8"x24 threads, hex base 8 = Plastic, snap-in type Notes: Codes 1, 3 and 6 are similar in size to 7/16" bushings (not exact equivalent). Code 4 is similar in size to a 15/32" bushing (not exact equivalent)											
6. Terminals: A = Quick connect .250" (6.35mm), straight B = Quick connect .250" (6.35mm), bent 90° C = #8-32 screw, bent 90° (screws installed) † D = Quick connect .250" (6.35mm), bent 45° E = Quick connect .250" (6.35mm), bent 90° opposite F = #8-32 screw, bent 45° (screws installed) G = QC .250" (6.35mm) and #8-32 screw, bent 90° (screw installed) †Not VDE											
7. Mounting Hardware: 4 = Metal, knurled nut/hex nut 6 = Metal, hex nut 12 = Metal, knurled nut 15 = Metal, two hex nuts and one lockwasher 18 = Metal, one hex nut and one lockwasher 7 = Plastic, knurled nut 8 = Plastic, knurled nut with small hole 22 = Plastic knurled nut, metal lockwasher 99 = None											
8. Mounting Hardware Packaging: A = Assembled to bushing B = Bulk unassembled C = No mounting hardware											
9. Maximum Operating Voltage: 1 = 250VAC 2 = 125VAC / 50VDC											
10. Nameplate: 0 = None 2 = Silver color printing on black 1 = Embossed aluminum 3 = Black printing on silver color											
11. Specify Amp Rating:											
5	7	10	15	25†	35*††						
6	8	12	20	30†	40*††	*UL1077, but not UL1500	†Not VDE	†Not CSA			
12. UL Recognition: Leave Blank = UL1077 recognized breaker M = Model meeting Ignition Protection requirements in accordance with UL 1500, in addition to UL1077 recognition (not available with models >30A rating). Code M breakers are not VDE approved or CSA certified.											

Our authorized distributors are more likely to stock the following items for immediate delivery.

W54-XB1A4A10-5 W54-XB1A4A10-15 W54-XB1A4A10-25
W54-XB1A4A10-10 W54-XB1A4A10-20 W54-XB1A4A10-30

ORDERING NOTE:

Mounting hardware can be ordered separately. Some options are subject to extended leadtimes and significant minimum order quantities.

Termination Options

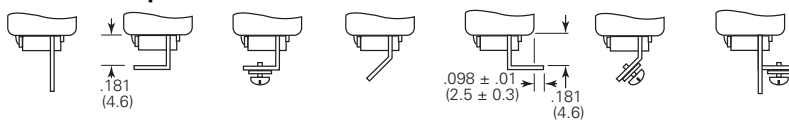

Option A Standard .250 QC Straight	Option B .250 QC 90°	Option C #8-32 Screw 90°	Option D Special .250 QC 45°	Option E .250 QC/PCB 270°	Option F #8-32 Screw 45°	Option H .250 QC Straight with #8-32 Load Term. Bent 90°
--	-----------------------------------	---------------------------------------	--	---	---------------------------------------	--

Mounting Bushings and Recommended Panel Cutouts



Mounting Hardware Options



Optional Bottom Marking of Rating



Mounting Hardware Dimensions

Dimension Code	Bushing Diameter	Plastic Knurled Nut	Integrated Plastic Knurled Nut w/Holes	Metal Knurled Nut	Metal Hex Nut	Lockwasher
A	3/8"	.74 (18.8)	-	.56 (14.2)	.55 (14.0)	.49 (12.5)
	M11	.74 (18.8)	.74 (18.8)	.59 (15.0)	.55 (14.0)	.587 (14.9)
	M12	-	-	.59 (15.0)	.55 (14.0)	.626 (15.9)
B	3/8"	.126 (3.2)	-	.079 (2.0)	.079 (2.0)	.02 (.5)
	M11	.126 (3.2)	.13 (3.3)	.102 (2.6)	.118 (3.0)	.02 (.5)
	M12	-	-	.102 (2.6)	.079 (2.0)	.02 (.5)

Mounting Hardware Ordering Information

Mounting Bushing Material	Mounting Bushing Code	Plastic Knurled Nut	Integrated Plastic Knurled Nut w/Holes	Metal Knurled Nut	Metal Hex Nut	Lockwasher
Metal	1 (M11)	-	-	1423696-4	1423696-6	1-1423696-2
	2 (3/8")	-	-	1-1423696-0	1423696-3	1-1423696-1
	3 (M11)	-	-	1423696-4	1423696-6	1-1423696-2
	4 (M12)	-	-	1423696-5	1423696-7	1-1423696-3
Plastic	6 (M11)	1423696-8	2-1423696-2	-	-	-
	8 (3/8")	1423696-2	-	-	-	-

Nameplates



© 2009 by Tyco Electronics Corporation. All Rights Reserved.
P&B, TE logo and Tyco Electronics are trademarks.