



26PC01SMT



Actual product appearance may vary.

Pressure Sensors: Measurement Type:
Gage, Vacuum Gage, Wet/Wet
Differential; Unamplified; Pressure
Range: ± 1.0 psi; Port Style: Straight

Features

- Alignment pins for position accuracy
- Small package size (less than one half the size of the 26PC) and compact surface mount profile
- 3,18 mm [0.125 in] diameter pick-up feature for use in pick and place machines
- Maximum peak reflow temperature of 260 °C [500 °F]
- Gage, vacuum gage, differential gage, wet/wet differential sensing available in one package
- True wet/wet differential sensing
- Proven elastomeric interconnections of the 20PC family
- Temperature compensation
- End point calibration
- Sensor consists of only five components
- Elastomeric construction
- Wide operating temperature range of -40 °C to 85 °C [-40 °F to 185 °F]

Description

The 26PC SMT (Surface Mount Technology) Series pressure sensor, the first offering in the 20PC SMT family of pressure sensors, is a small, low cost, high value, pressure sensing solution for use with printed circuit boards (PCBs). Based on the long established reliability and accuracy of the 26PC pressure sensor, the 26PC SMT offers reduced size with true SMT capability. The smaller size reduces the sensor's footprint on the PCB, thereby reducing the size of the PCB. The 26PC SMT is the first pressure sensor capable of being used with other SMT components on the PCB, helping to lower installation costs and eliminate secondary operations.

The sensor features Wheatstone bridge construction, silicon piezoresistive technology, and ratiometric output for proven application flexibility, design simplicity and ease of manufacture.

Although designed for the medical industry, the 20PC SMT pressure sensor may be applied in any industry that requires a surface mount pressure sensor.

Potential Applications

Medical

- CPAP (Continuous Positive Airway Pressure) equipment
- Respirators and ventilators
- Blood glucose monitors
- Oxygen conservers
- Oxygen concentrators
- Nebulizers

Environmental

- Residential fuel cells

Industrial

- Soft drink dispensing

Product Specifications	
Measurement Type	Wet-Wet Differential/Gage/ Vacuum Gage
Signal Conditioning	Unamplified
Pressure Range	± 1.0 psi
Maximum Overpressure	20.0 psi
Supply Voltage	10.0 Vdc typ., 16.0 Vdc max.
Compensated	Yes
Output Calibration	Yes
Response Time	1 ms max.
Termination	Surface Mount Technology; 2 x 2
Port Style	Straight: 1,88 mm dia [0.074 in]
Package Style	Honeywell - 20PC SMT
Linearity	± 0.50% span typ., ± 1.75% span max.
Typical Sensitivity	16.7 mV typ.
Full Scale Span	14.7 mV min, 16.7 mV typ., 18.7 mV max.
Null Offset	-2 mV min, 0 mV typ., 2 mV max
Null Shift over Temperature	± 1.0 mV max.
Span Shift Over Temperature	± 1.5% span typ., ± 4.5% span max.
Repeatability & Hysteresis Error	± 0.20 % span typ.
Input Resistance	5.5 kOhm min., 7.5 kOhm typ., 11.5 kOhm max.
Output Resistance	1.5 kOhm min., 2.5 kOhm typ., 3.0 kOhm max.
Shock	Qualification tested to 150 g
Vibration	MIL-STD-202 Method 213 (150 g half sine 11 ms)
Weight	0.5 g [0.0176 oz]
Operating Temperature Range	-40 °C to 85 °C [-40 °F to 185 °F]
Compensated Temperature Range	0 °C to 50 °C [32 °F to 122 °F]
Storage Temperature Range	-55 °C to 100 °C [-67 °F to 212 °F]
Media Compatibility	Limited to media which will not attack polyetherimide, silicon, flourosilicone, silicone, EPDM and neoprene seals.
UNSPSC Code	411121
UNSPSC Commodity	411121 Transducers
Comment	Lead free solder and no clean flux; wet/wet differential
Availability	Global
Series Name	26PC SMT

REV	DOCUMENT	CHANGED BY	CHECK
10	0036788	SSK 21 JAN 08	BLR

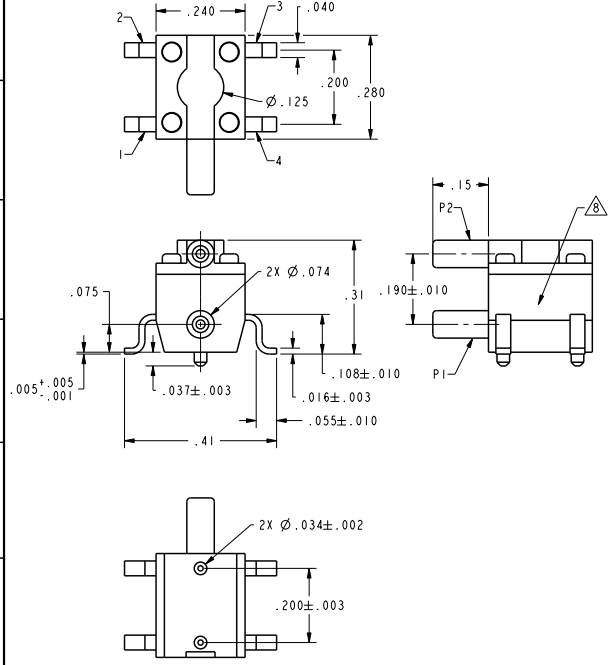

- NOTES
- 1 - SPAN IS THE ALGEBRAIC DIFFERENCE BETWEEN OUTPUT AT MAXIMUM RATED OPERATING PRESSURE AND OUTPUT AT 0 PSI
 - 2 - TEMPERATURE ERROR IS CALCULATED WITH RESPECT TO 25°C
 - 3 - INPUT MEDIA LIMITED ONLY TO THOSE MATERIALS THAT WILL NOT ATTACK SILICON, THE HOUSING MATERIAL OR SEAL MATERIAL
 - 4 - SENSOR IS OPERATIONAL OVER VACUUM PRESSURE RANGE
 - 5 - RATIO METRIC TO SUPPLY VOLTAGE
 - 6 - RECOMMENDED TUBING SIZE: .062 I.D. X .031 WALL THICKNESS
- FOR COMMON MODE NULL OFFSET INFORMATION, SEE APPLICATION NOTES
- LASER MARK DATE CODE AND CATALOG LISTING THIS AREA

GENERAL OPERATING CHARACTERISTICS										
(ELECTRICAL PERFORMANCE AT 10.00 \pm 0.01 VDC EXCITATION, 25°C)										
OPERATING PRESSURE RANGE (PSIG)	0 - 1			0 - 5			0 - 15			
CATALOG LISTING	26PC01SMT			26PC05SMT			26PC15SMT			
SPAN (P2>P1) Δ	MIN	NOM	MAX	MIN	NOM	MAX	MIN	NOM	MAX	UNITS
SPAN (P2>P1) Δ	14.7	16.7	18.7	47	50	53	96	100	104	mV
NULL OFFSET	-2.0	0	+2.0	-2.0	0	+2.0	-2.0	0	+2.0	mV
LINEARITY (BFSL, P2>P1)	MIN	TYP	MAX	MIN	TYP	MAX	MIN	TYP	MAX	UNITS
LINEARITY (BFSL, P2>P1)		± 0.50	+1.75		± 0.50	+1.5		± 0.50	+1.0	%SPAN
NULL SHIFT (0 TO 25°C, 25 TO 50°C) Δ			± 1.0			± 1.0			± 1.0	mV
SPAN SHIFT (0 TO 25°C, 25 TO 50°C) P2>P1 Δ			± 1.5			± 1.0			± 1.5	%SPAN
REPEATABILITY AND HYSTERESIS			± 0.2			± 0.2			± 0.2	%SPAN
OVERPRESSURE (P2>P1 ; P1>P2)			20			20			45	PSI
COMMON MODE PRESSURE Δ										
ALL PRESSURE RANGES	MIN	TYP	MAX	UNITS						
EXCITATION VOLTAGE		10	16	VDC						
INPUT RESISTANCE	5.5K	7.5K	11.5K	OHMS						
OUTPUT RESISTANCE	1.5K	2.5K	3.0K	OHMS						
RESPONSE TIME			1.0	mS						
TEMPERATURE RANGES										
STORAGE	-55°C TO +100°C (-67°F TO +212°F)									
OPERATE	-40°C TO +85°C (-40°F TO +185°F)									
COMPENSATED	0 TO +50°C (+32°F TO +122°F)									

CATALOG LISTING	BRANDING CODE
26PC01SMT	601F
26PC05SMT	605F
26PC15SMT	615F
(D)	6100FG
26PC01SMT-SAMPLES	601F
26PC05SMT-SAMPLES	605F
26PC15SMT-SAMPLES	615F

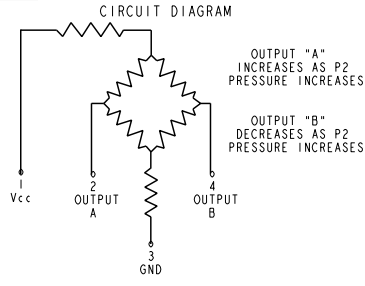
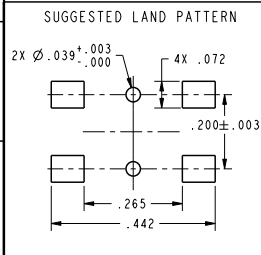

UNLESS OTHERWISE SPECIFIED TOLERANCES ARE:	FRAMES	CHUCK	WJC	10JUL01
NO PLACE	X	$\pm .040$	± 1	10JUL01
ONE PLACE	.X	$\pm .030$	± 0.4	
TWO PLACE	.XX	$\pm .015$	± 0.15	
THREE PLACE	.XXX	$\pm .005$	\pm	
ANGLES		\pm	\pm	
RAW MATERIAL-COMMERCIAL STANDARD				

THIRD ANGLE PROJECTION

3D PTC ASME Y14.5M-1994

Honeywell

TITLE: BRIDGE PRESSURE SENSOR

SIZE: C DWG TYPE: I DRAWING NAME: 26PC SMT SERIES CHART 1 REV: 10

SCALE: 5:1 WEIGHT: 5 GRAMS SHEET: 1 OF 1