

LOW VOLTAGE 4Ω SPDT SWITCH

- HIGH SPEED:
 $t_{PD} = 0.3ns$ (TYP.) at $V_{CC} = 5V$
 $t_{PD} = 0.4ns$ (TYP.) at $V_{CC} = 3.3V$
- LOW POWER DISSIPATION:
 $I_{CC} = 1\mu A$ (MAX.) at $T_A = 25^\circ C$
- LOW "ON" RESISTANCE:
 $R_{ON} = 4\Omega$ (MAX. $T_A = 25^\circ C$) AT $V_{CC} = 5V$
 $R_{ON} = 6\Omega$ (TYP.) AT $V_{CC} = 3V$
- WIDE OPERATING VOLTAGE RANGE:
 V_{CC} (OPR) = 1.8V TO 5.5V SINGLE SUPPLY

DESCRIPTION

The STG719 is an high-speed S.P.D.T. (Single Pole Double Throw) SWITCH fabricated in silicon gate C²MOS technology. It designed to operate from 1.8V to 5.5V, making this device ideal for portable applications, audio signal routing, video switching, mobile and communication systems. It offers 4Ω ON-Resistance Max at 5V 25°C and very low ON-Resistance Flatness. Additional key features are fast switching speed ($t_{ON} = 7ns$,



Table 1: Order Codes

PACKAGE	T & R
SOT23-6L	STG719STR

$t_{OFF} = 4.5ns$), Break Before Make Delay Time and Low Power Consumption.

All inputs and outputs are equipped with protection circuits against static discharge, giving them ESD immunity and transient excess voltage. It's available in the commercial and extended temperature range.

Figure 1: Pin Connection And IEC Logic Symbols

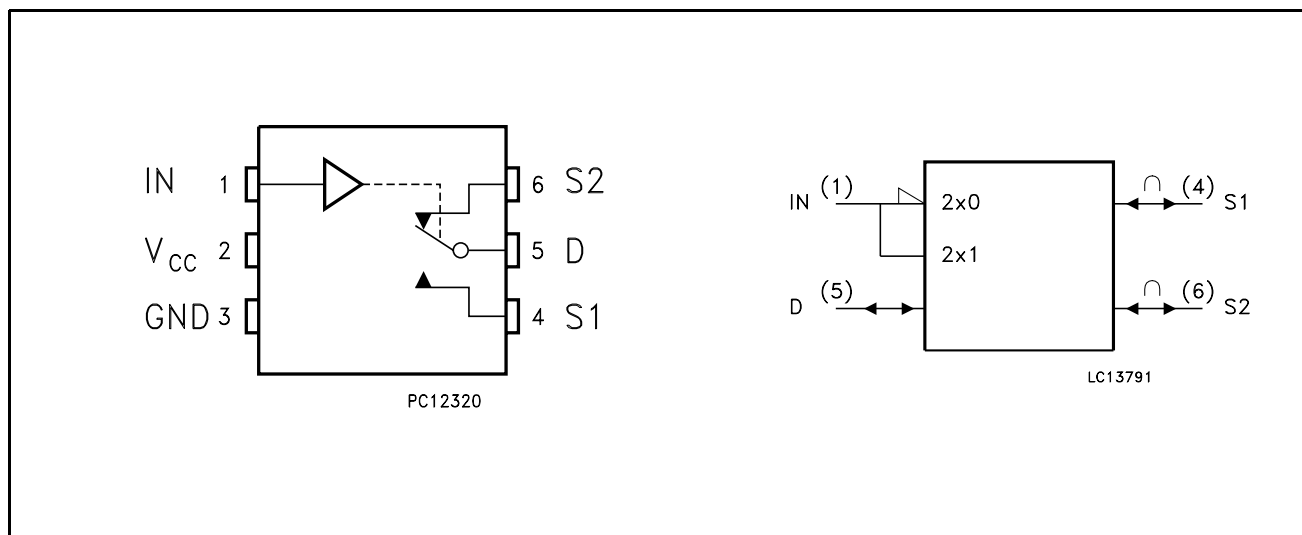

Figure 2: Input Equivalent Circuit

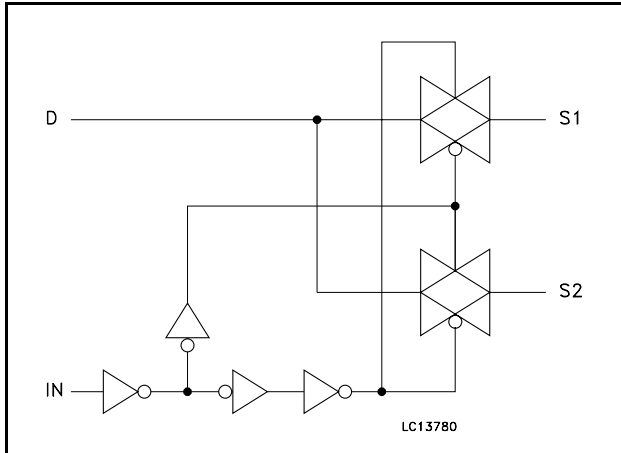

Table 2: Pin Description

PIN N°	SYMBOL	NAME AND FUNCTION
1	IN	Control
4, 6	S1, S2	Independent Channel
5	D	Common Channel
2	V _{CC}	Positive Supply Voltage
3	GND	Ground (0V)

TRUTH TABLE

IN	SWITCH S1	SWITCH S2
L	ON	OFF
H	OFF	ON

Table 3: Absolute Maximum Ratings

Symbol	Parameter	Value	Unit
V _{CC}	Supply Voltage	-0.5 to +7.0	V
V _I	DC Input Voltage	-0.5 to V _{CC} + 0.5	V
V _{IC}	DC Control Input Voltage	-0.5 to V _{CC} + 0.5	V
V _O	DC Output Voltage	-0.5 to V _{CC} + 0.5	V
I _{IK}	DC Input Diode Current	± 20	mA
I _{OK}	DC Output Diode Current	± 20	mA
I _O	DC Output Current	± 50	mA
I _{CC} or I _{GND}	DC V _{CC} or Ground Current	± 50	mA
T _{stg}	Storage Temperature	-65 to +150	°C
T _L	Lead Temperature (10 sec)	300	°C

Absolute Maximum Ratings are those values beyond which damage to the device may occur. Functional operation under these conditions is not implied

Table 4: Recommended Operating Conditions

Symbol	Parameter	Value	Unit
V _{CC}	Supply Voltage (note 1)	1.8 to 5.5	V
V _I	Input Voltage	0 to V _{CC}	V
V _{IC}	Control Input Voltage	0 to V _{CC}	V
V _O	Output Voltage	0 to V _{CC}	V
T _{op}	Operating Temperature	-55 to 125	°C
dt/dv	Input Rise and Fall Time on control pin (note 2)	0 to 10	ns/V
dt/dv	Input Rise and Fall Time on I/O pins	0 to DC	ns/V

1) Truth Table guaranteed: 1.2V to 6V
 2) V_{IN} from 30% to 70% of V_{CC}

Table 5: DC Specifications

Symbol	Parameter	Test Condition		Value						Unit	
		V _{CC} (V)		T _A = 25°C			-40 to 85°C		-55 to 125°C		
				Min.	Typ.	Max.	Min.	Max.	Min.		Max.
V _{IHC}	High Level Control Input Voltage	3.3(*)		2.0			2.0		2.0		V
		5.0(**)		2.4			2.4		2.4		
V _{ILC}	Low Level Control Input Voltage	3.3(*)				0.4		0.4		0.4	V
		5.0(**)				0.8		0.8		0.8	
R _{ON}	ON Resistance	3.3(*)	V _S = 0 to V _{CC} I _S = 10mA		6	7		10		12	Ω
		5.0(**)				4		5		6	
ΔR _{ON}	ON Resistance	3.3(*)	V _S = 0 to V _{CC} I _S = 10mA		0.1			0.4			Ω
		5.0(**)			0.1		0.4				
R _{FLATON}	ON Resistance fLATNESS	3.3(*)	V _S = 0 to V _{CC} I _S = 10mA		2.5						Ω
		5.0(**)			0.75						
I _{SOFF}	Source OFF Leakage	3.3(*)	V _S = 1V or V _{CC} V _{DD} = V _{CC} or 1V V _{IN} = V _{CC} or GND		±0.01	±0.25		±0.35		±3.5	nA
		5.0(**)			±0.01	±0.25		±0.35		±3.5	
I _{SON}	Channel ON Leakage	3.3(*)	V _S = V _D = 1V to V _{CC} - 2.5V V _{IN} = V _{IHC}		±0.01	±0.25		±0.35		±3.5	nA
		5.0(**)			±0.01	±0.25		±0.35		±3.5	
I _{IN}	Control Input Leakage Current	3.3(*)	V _I = V _{IH} or V _{IL}		0.005			±0.1		±1	μA
		5.0(**)			0.005		±0.1		±1		
I _{CC}	Quiescent Supply Current	3.3(*)	V _I = V _{CC} or GND		0.001	1		1		2	μA
		5.0(**)			0.001		1		2		

(*) Voltage range is 3.3V ± 0.3V

(**) Voltage range is 5V ± 0.5V

Table 6: AC Electrical Characteristics ($C_L = 35\text{pF}$, $R_L = 300\Omega$)

Symbol	Parameter	Test Condition		Value						Unit	
		V _{CC} (V)		T _A = 25°C			-40 to 85°C		-55 to 125°C		
				Min.	Typ.	Max.	Min.	Max.	Min.		Max.
t _{PD}	Delay Time	3.3(*)	V _S = 3V square wave f = 1MHz t _r = t _f = 6ns		0.4	0.8		1.2		2.4	ns
		5.0(**)			0.3	0.6		1.0		2.0	
t _{ON}	ON Channel Time	3.3(*)	V _S = 2V		10			16		19	ns
		5.0(**)	V _S = 3V		7			11		13	
t _{OFF}	OFF Channel Time	3.3(*)	V _S = 2V		5.5			7		8.5	ns
		5.0(**)	V _S = 3V		4.5			6		7.5	
t _D	Break Before Make Time Delay	3.3(*)	V _S = 2V	1	4						ns
		5.0(**)	V _S = 3V	1	4						
C _{SOFF}	OFF Channel Capacitance				19						pF
C _{SON}	ON Channel Capacitance				33						pF

(*) Voltage range is 3.3V ± 0.3V

(**) Voltage range is 5.0V ± 0.5V

Table 7: Analog Switch Characteristics (GND = 0V; T_A = 25°C)

Symbol	Parameter	Test Condition			Value	Unit	
		V _{CC} (V)			Typ.		
f _{MAX}	Frequency Response (Switch ON)	3.3(*)	Bandwidth at -3dB			200	MHz
		5.0(**)				200	
	Feed through Attenuation (Switch OFF)	3.3(*)	f _{IN} = 10MHz sine wave			-40	dB
		3.3(*)	f _{IN} = 1MHz sine wave			-74	
		5.0(**)	f _{IN} = 10MHz sine wave			-40	
		5.0(**)	f _{IN} = 1MHz sine wave			-74	
	Crosstalk (Control Input to Signal Output)	3.3(*)	f _{IN} = 10MHz sine wave			-39	dB
		3.3(*)	f _{IN} = 1MHz sine wave			-52	
		5.0(**)	f _{IN} = 10MHz sine wave			-39	
		5.0(**)	f _{IN} = 1MHz sine wave			-52	

(*) Voltage range is 3.3V ± 0.3V

(**) Voltage range is 5.0V ± 0.5V

TEST CIRCUITS

Figure 3: On Resistance

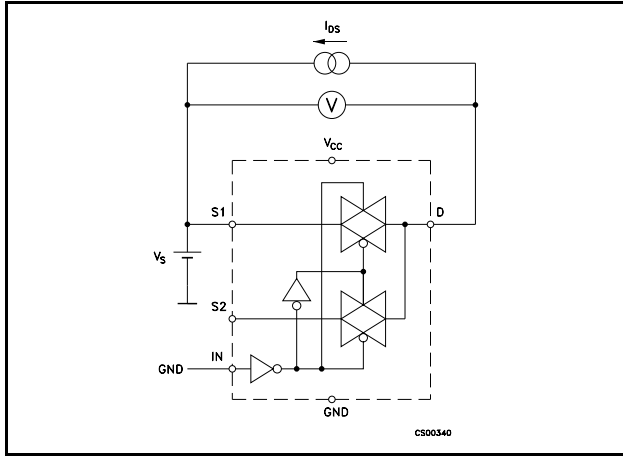

Figure 6: Off Isolation

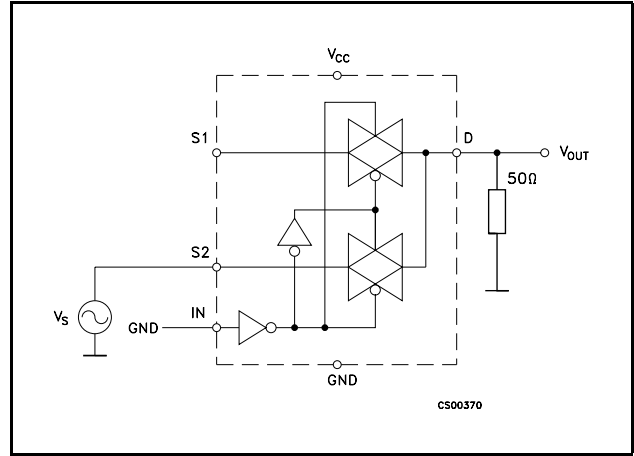

Figure 4: On Leakage

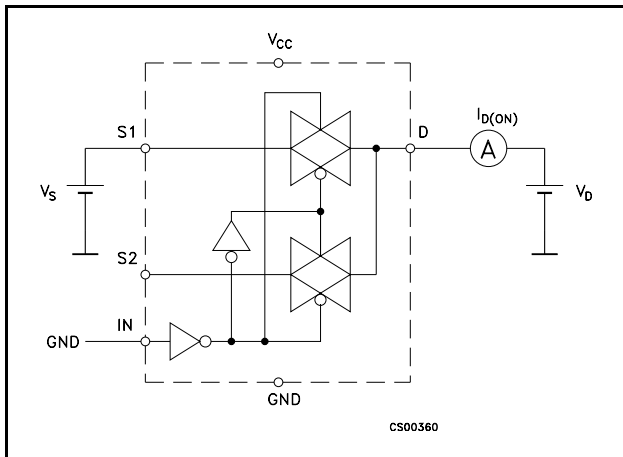

Figure 7: Bandwidth

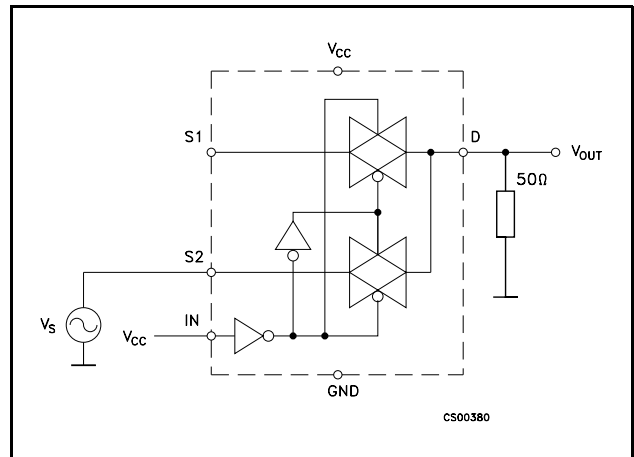

Figure 5: Off Leakage

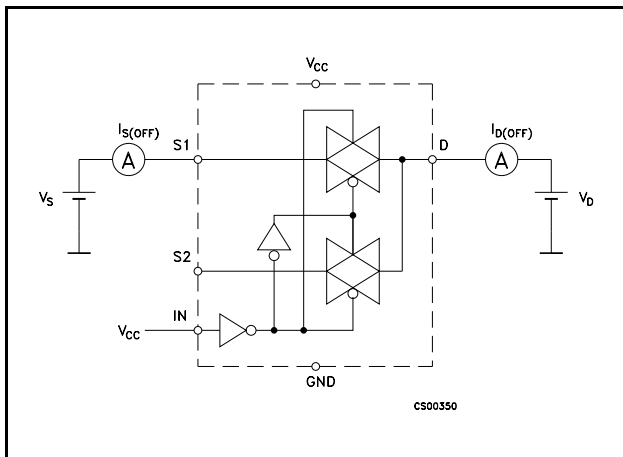

Figure 8: Channel To Channel Crosstalk

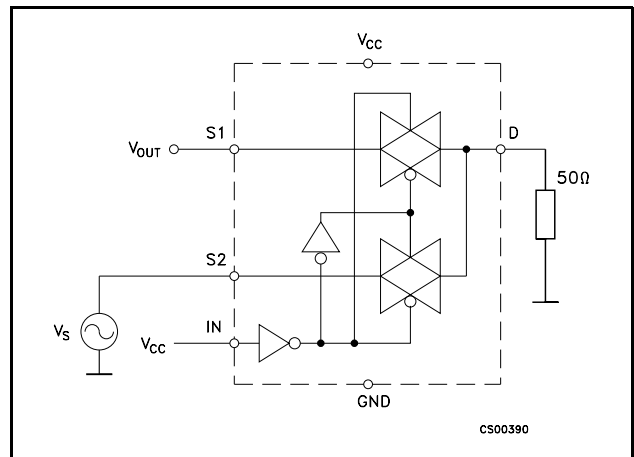

Figure 9: Switching Times

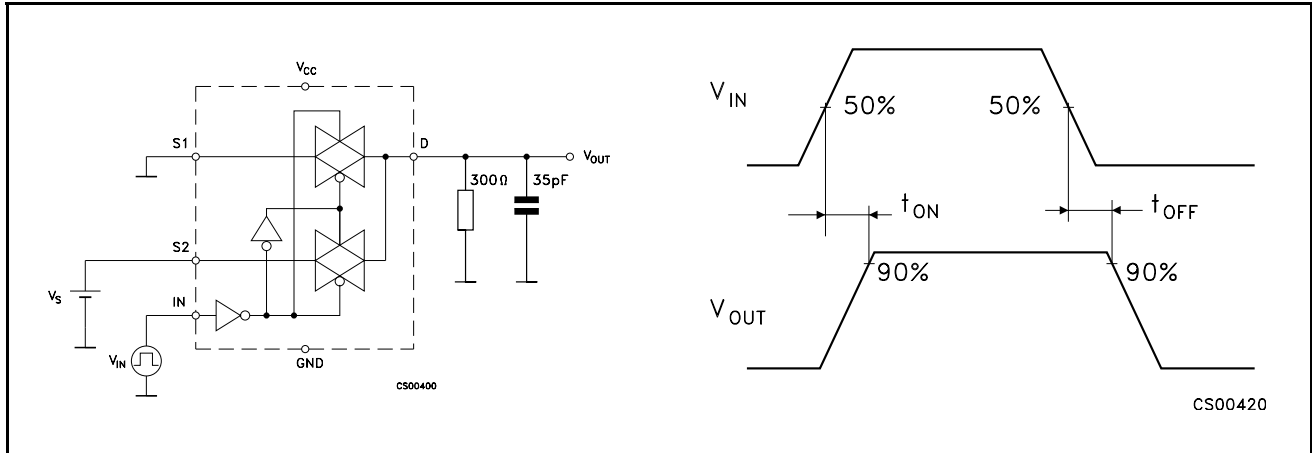
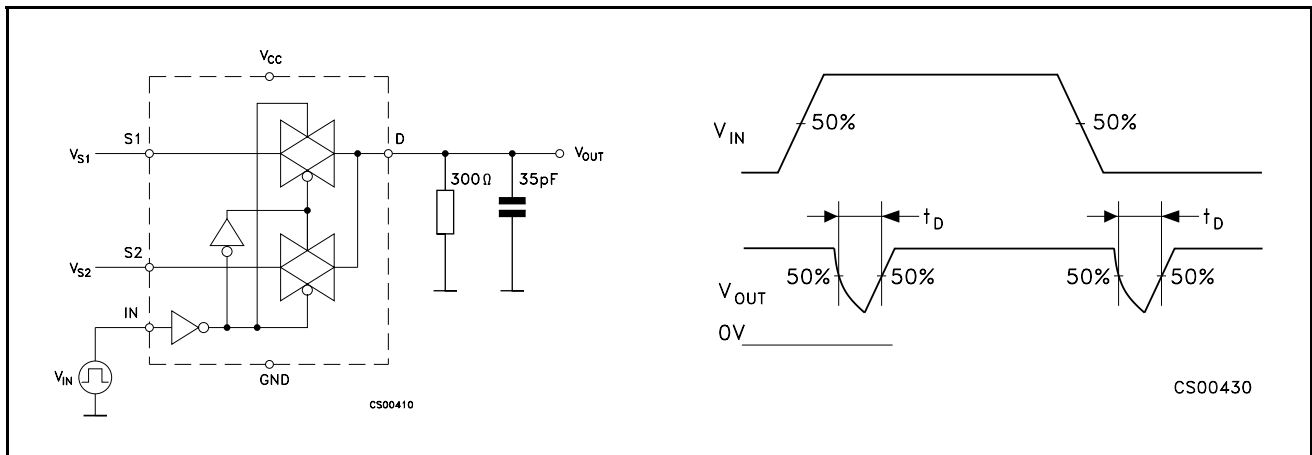
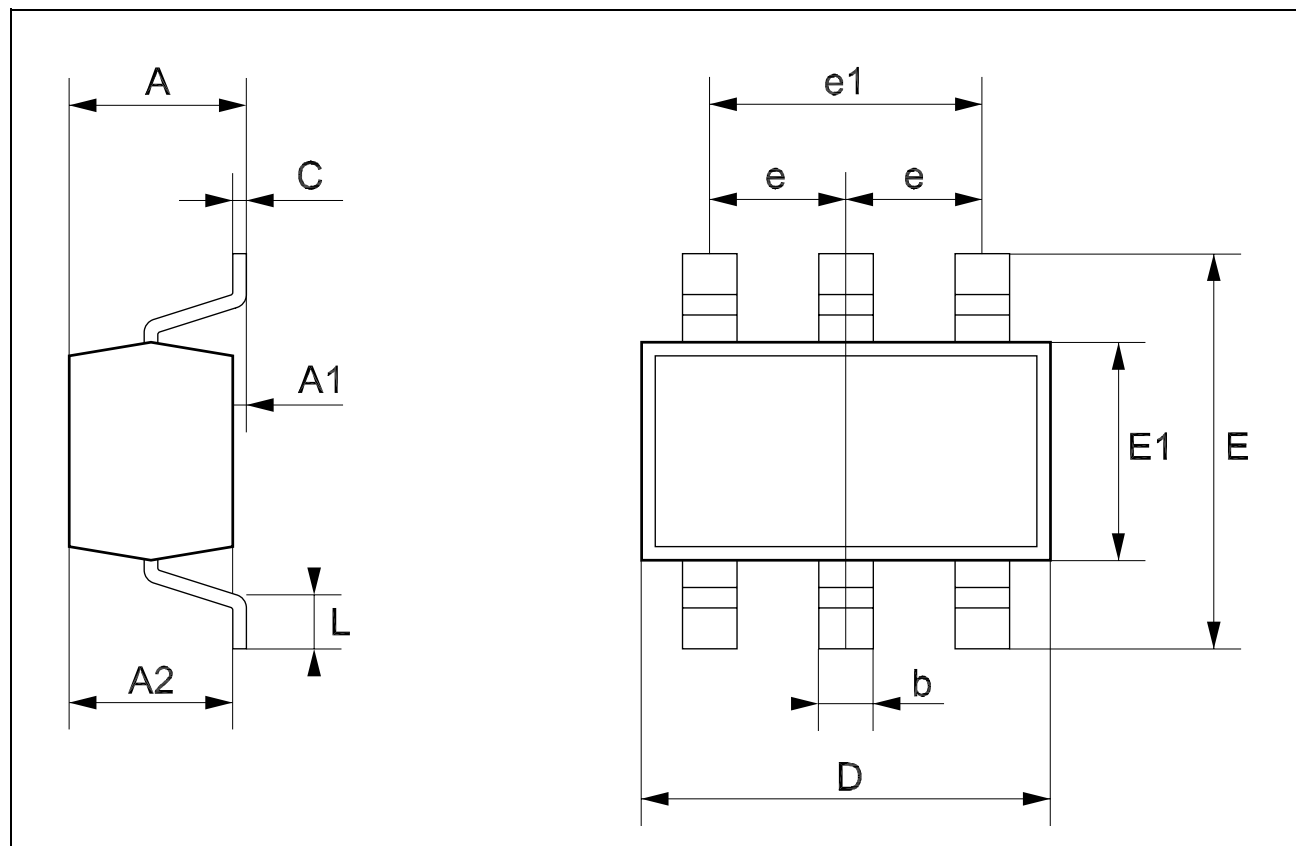

Table 8: Break Before Make Time Delay



SOT23-6L MECHANICAL DATA

DIM.	mm.			mils		
	MIN.	TYP	MAX.	MIN.	TYP.	MAX.
A	0.90		1.45	35.4		57.1
A1	0.00		0.15	0.0		5.9
A2	0.90		1.30	35.4		51.2
b	0.35		0.50	13.7		19.7
C	0.09		0.20	3.5		7.8
D	2.80		3.00	110.2		118.1
E	2.60		3.00	102.3		118.1
E1	1.50		1.75	59.0		68.8
e		0.95			37.4	
e1		1.9			74.8	
L	0.35		0.55	13.7		21.6



Tape & Reel SOT23-xL MECHANICAL DATA

DIM.	mm.			inch		
	MIN.	TYP	MAX.	MIN.	TYP.	MAX.
A			180			7.086
C	12.8	13.0	13.2	0.504	0.512	0.519
D	20.2			0.795		
N	60			2.362		
T			14.4			0.567
Ao	3.13	3.23	3.33	0.123	0.127	0.131
Bo	3.07	3.17	3.27	0.120	0.124	0.128
Ko	1.27	1.37	1.47	0.050	0.054	0.058
Po	3.9	4.0	4.1	0.153	0.157	0.161
P	3.9	4.0	4.1	0.153	0.157	0.161

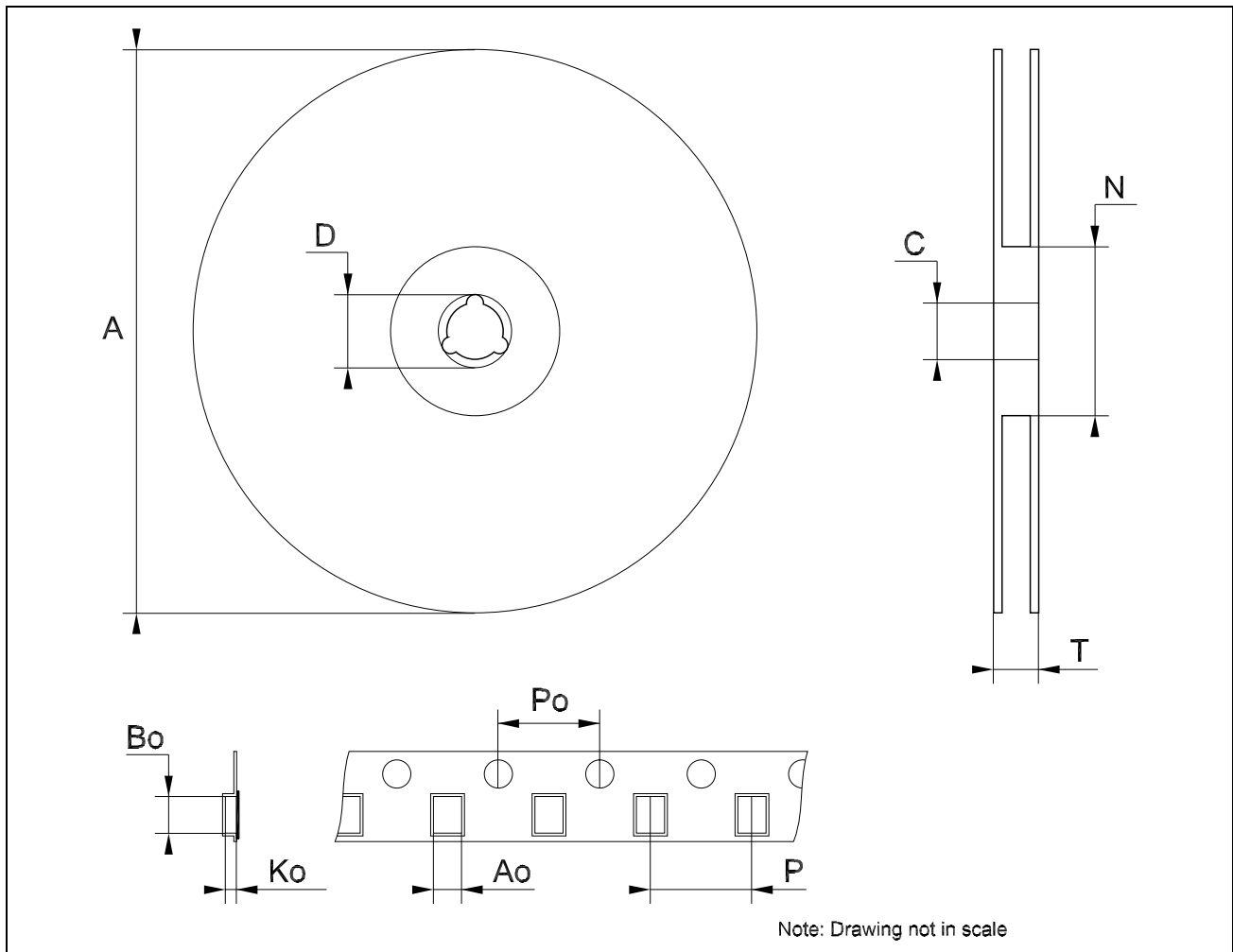

Table 9: Revision History

Date	Revision	Description of Changes
25-Nov-2004	8	Mistake on Figure 1.

Information furnished is believed to be accurate and reliable. However, STMicroelectronics assumes no responsibility for the consequences of use of such information nor for any infringement of patents or other rights of third parties which may result from its use. No license is granted by implication or otherwise under any patent or patent rights of STMicroelectronics. Specifications mentioned in this publication are subject to change without notice. This publication supersedes and replaces all information previously supplied. STMicroelectronics products are not authorized for use as critical components in life support devices or systems without express written approval of STMicroelectronics.

The ST logo is a registered trademark of STMicroelectronics

All other names are the property of their respective owners

© 2004 STMicroelectronics - All Rights Reserved

STMicroelectronics group of companies

Australia - Belgium - Brazil - Canada - China - Czech Republic - Finland - France - Germany - Hong Kong - India - Israel - Italy - Japan - Malaysia - Malta - Morocco - Singapore - Spain - Sweden - Switzerland - United Kingdom - United States of America

www.st.com