Programmable voltage reference

Features

- Adjustable output voltage: 2.5 to 36 V
- Sink current capability: 1 to 100 mA
- Typical output impedance: 0.22 Ω
- 1% and 2% voltage precision

Description

The TL431 is a programmable shunt voltage reference with guaranteed temperature stability over the entire operating temperature range.

The output voltage may be set to any value between 2.5 V and 36 V with two external resistors.

The TL431 operates with a wide current range from 1 to 100 mA with a typical dynamic impedance of 0.22 Ω .



Z
TO-92
(Plastic package)



D
SO-8
(Batwing plastic micropackage)

2 Absolute maximum ratings and operating conditions

Table 1. Absolute maximum ratings

Symbol	Parameter	Value	Unit
V_{KA}	Cathode to anode voltage	37	V
I_k	Continuous cathode current range	-100 to +150	mA
I_{ref}	Reference input current range	-0.05 to +10	mA
P_{diss}	Power dissipation ⁽¹⁾ TO-92 SO-8 batwing	625 960	mW
T_{stg}	Storage temperature range	-65 to +150	°C
ESD	HBM: human body model ⁽²⁾	2000	V
	MM: machine model ⁽³⁾	200	
	CDM: charged device model ⁽⁴⁾	1500	

- P_{diss} is calculated with $T_{amb} = +25^\circ\text{C}$, $T_j = +150^\circ\text{C}$ and $R_{thja} = 200^\circ\text{C/W}$ for TO-92 package
 $R_{thja} = 130^\circ\text{C/W}$ for SO-8 batwing package
- Human body model: A 100 pF capacitor is charged to the specified voltage, then discharged through a 1.5 k Ω resistor between two pins of the device. This is done for all couples of connected pin combinations while the other pins are floating.
- Machine model: A 200 pF capacitor is charged to the specified voltage, then discharged directly between two pins of the device with no external series resistor (internal resistor < 5 Ω). This is done for all couples of connected pin combinations while the other pins are floating.
- Charged device model: all pins and the package are charged together to the specified voltage and then discharged directly to the ground through only one pin. This is done for all pins.

Table 2. Operating conditions

Symbol	Parameter	Value	Unit
V_{KA}	Cathode to anode voltage	V_{ref} to 36	V
I_k	Cathode current	1 to 100	mA
T_{oper}	Operating free-air temperature range TL431C/AC TL431I/AI	0 to +70 -40 to +105	°C

3 Electrical characteristics

Table 3. $T_{amb} = 25^{\circ}\text{C}$ (unless otherwise specified)

Symbol	Parameter	TL431C			TL431AC			Unit
		Min.	Typ.	Max.	Min.	Typ.	Max.	
V_{ref}	Reference input voltage $V_{KA} = V_{ref}$, $I_k = 10\text{ mA}$, $T_{amb} = 25^{\circ}\text{C}$ $T_{min} \leq T_{amb} \leq T_{max}$	2.44 2.423	2.495	2.55 2.567	2.47 2.453	2.495	2.52 2.537	V
ΔV_{ref}	Reference input voltage deviation over temperature range ⁽¹⁾ $V_{KA} = V_{ref}$, $I_k = 10\text{ mA}$, $T_{min} \leq T_{amb} \leq T_{max}$		3	17		3	15	mV
$\frac{\Delta V_{ref}}{\Delta V_{ka}}$	Ratio of change in reference input voltage to change in cathode to anode voltage $I_k = 10\text{ mA}$ - $\Delta V_{KA} = 10\text{ V}$ to V_{ref} $\Delta V_{KA} = 36\text{ V}$ to 10 V	-2.7 -2	-1.4 -1		-2.7 -2	-1.4 -1		mV/V
I_{ref}	Reference input current $I_k = 10\text{ mA}$, $R1 = 10\text{ k}\Omega$, $R2 = \infty$ $T_{amb} = 25^{\circ}\text{C}$ $T_{min} \leq T_{amb} \leq T_{max}$		1.8	4 5.2		1.8	4 5.2	μA
ΔI_{ref}	Reference input current deviation over temperature range $I_k = 10\text{ mA}$, $R1 = 10\text{ k}\Omega$, $R2 = \infty$ $T_{min} \leq T_{amb} \leq T_{max}$		0.4	1.2		0.4	1.2	μA
I_{min}	Minimum cathode current for regulation $V_{KA} = V_{ref}$		0.5	1		0.5	0.6	mA
I_{off}	Off-state cathode current		2.6	1000		2.6	1000	nA
$ Z_{KA} $	Dynamic impedance ⁽²⁾ $V_{KA} = V_{ref}$, $\Delta I_k = 1$ to 100 mA , $f \leq 1\text{ kHz}$		0.22	0.5		0.22	0.5	Ω

1. See definition of [Reference input voltage deviation over temperature range](#).

2. The dynamic impedance is defined as $|Z_{KA}| = \frac{\Delta V_{KA}}{\Delta I_k}$

Table 4. $T_{amb} = 25^{\circ}\text{C}$ (unless otherwise specified)

Symbol	Parameter	TL431I			TL431AI			Unit
		Min.	Typ.	Max.	Min.	Typ.	Max.	
V_{ref}	Reference input voltage $V_{KA} = V_{ref}$, $I_k = 10\text{ mA}$, $T_{amb} = 25^{\circ}\text{C}$ $T_{min} \leq T_{amb} \leq T_{max}$	2.44 2.41	2.495	2.55 2.58	2.47 2.44	2.495	2.52 2.55	V
ΔV_{ref}	Reference input voltage deviation over temperature range ⁽¹⁾ $V_{KA} = V_{ref}$, $I_k = 10\text{ mA}$, $T_{min} \leq T_{amb} \leq T_{max}$		7	30		7	30	mV
$\frac{\Delta V_{ref}}{\Delta V_{ka}}$	Ratio of change in reference input voltage to change in cathode to anode voltage $I_k = 10\text{ mA}$, $\Delta V_{KA} = 10\text{V to } V_{ref}$ $\Delta V_{KA} = 36\text{V to } 10\text{V}$	-2.7 -2	-1.4 -1		-2.7 -2	-1.4 -1		mV/V
I_{ref}	Reference input current $I_k = 10\text{ mA}$, $R1 = 10\text{ k}\Omega$, $R2 = \infty$ $T_{amb} = 25^{\circ}\text{C}$ $T_{min} \leq T_{amb} \leq T_{max}$		1.8	4 6.5		1.8	4 6.5	μA
ΔI_{ref}	Reference input current deviation over temperature range $I_k = 10\text{ mA}$, $R1 = 10\text{ k}\Omega$, $R2 = \infty$ $T_{min} \leq T_{amb} \leq T_{max}$		0.8	2.5		0.8	1.2	μA
I_{min}	Minimum cathode current for regulation $V_{KA} = V_{ref}$		0.5	1		0.5	0.7	mA
I_{off}	Off-state cathode current		2.6	1000		2.6	1000	nA
$ Z_{KA} $	Dynamic impedance ⁽²⁾ $V_{KA} = V_{ref}$, $\Delta I_k = 1\text{ to } 100\text{ mA}$, $f \leq 1\text{ kHz}$		0.22	0.5		0.22	0.5	Ω

1. See definition of [Reference input voltage deviation over temperature range](#) below.

2. The dynamic impedance is defined as $|Z_{KA}| = \frac{\Delta V_{KA}}{\Delta I_k}$

Reference input voltage deviation over temperature range

ΔV_{ref} is defined as the difference between the maximum and minimum values obtained over the full temperature range.

$$\Delta V_{ref} = V_{ref\ max} - V_{ref\ min}$$

Figure 4. Reference input voltage deviation over temperature range

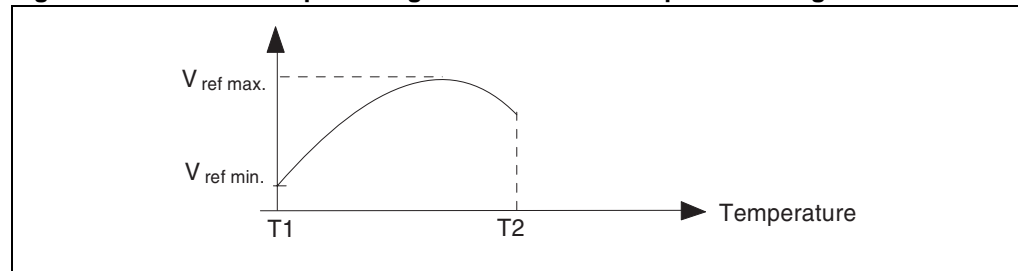

4.1 SO-8 package information

Figure 22. SO-8 package mechanical drawing

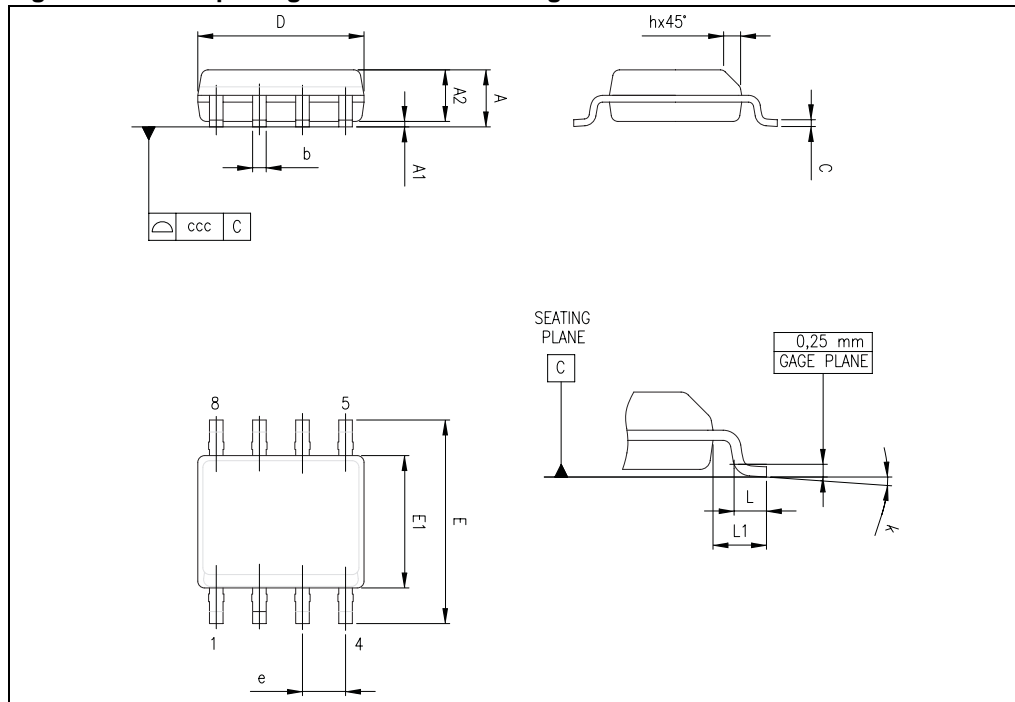

Table 5. SO-8 package mechanical data

Ref.	Dimensions					
	Millimeters			Inches		
	Min.	Typ.	Max.	Min.	Typ.	Max.
A			1.75			0.069
A1	0.10		0.25	0.004		0.010
A2	1.25			0.049		
b	0.28		0.48	0.011		0.019
c	0.17		0.23	0.007		0.010
D	4.80	4.90	5.00	0.189	0.193	0.197
E	5.80	6.00	6.20	0.228	0.236	0.244
E1	3.80	3.90	4.00	0.150	0.154	0.157
e		1.27			0.050	
h	0.25		0.50	0.010		0.020
L	0.40		1.27	0.016		0.050
k	1°		8°	1°		8°
ccc			0.10			0.004

5 Ordering information

Table 8. Order codes

Order code	Temperature range	Package	Packing	Marking
TL431CD TL431CDT	0°C to +70°C	SO-8	Tube or Tape and reel	431C
TL431ACD TL431ACDT				431AC
TL431CZ TL431CZT TL431CZ-AP		TO-92	Bulk or Tape or Ammopack	TL431C
TL431ACZ TL431ACZT TL431ACZ-AP				TL431AC
TL431ID TL431IDT	-40°C to + 105°C	SO-8	Tube or tape and reel	431I
TL431AID TL431AIDT				431AI
TL431IZ TL431IZT TL431IZ-AP		TO-92	Bulk or Tape or Ammopack	TL431I
TL431AIZ TL431AIZT TL431AIZ-AP				TL431AI
TL431IYD ⁽¹⁾ TL431IYDT ⁽¹⁾		SO-8 (automotive grade level)	Tube or tape and reel	431IY
TL431AIYD ⁽¹⁾ TL431AIYDT ⁽¹⁾				431AIY

1. Qualification and characterization according to AEC Q100 and Q003 or equivalent, advanced screening according to AEC Q001 & Q 002 or equivalent are on-going.