



L6571A L6571B

HIGH VOLTAGE HALF BRIDGE DRIVER WITH OSCILLATOR

- HIGH VOLTAGE RAIL UP TO 600V
- BCD OFF LINE TECHNOLOGY
- 15.6V ZENER CLAMP ON V_S
- DRIVER CURRENT CAPABILITY:
 - SINK CURRENT = 270mA
 - SOURCE CURRENT = 170mA
- VERY LOW START UP CURRENT: 150 μ A
- UNDER VOLTAGE LOCKOUT WITH HYSTERESIS
- PROGRAMMABLE OSCILLATOR FREQUENCY
- DEAD TIME 1.25 μ s (L6571A) or 0.72 μ s (L6571B)
- dV/dt IMMUNITY UP TO $\pm 50V/ns$
- ESD PROTECTION

DESCRIPTION

The device is a high voltage half bridge driver with built in oscillator. The frequency of the oscillator can be programmed using external resistor and capaci-

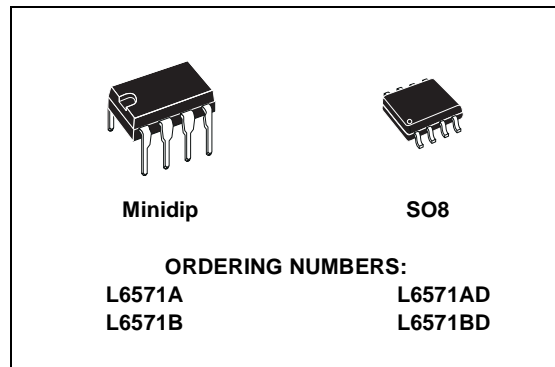

tor. The internal circuitry of the device allows it to be driven also by external logic signal.

The output drivers are designed to drive external n-channel power MOSFET and IGBT. The internal logic assures a dead time to avoid cross-conduction of the power devices.

Two version are available: L6571A and L6571B. They differ in the internal dead time: 1.25 μ s and 0.72 μ s (typ.)

BLOCK DIAGRAM

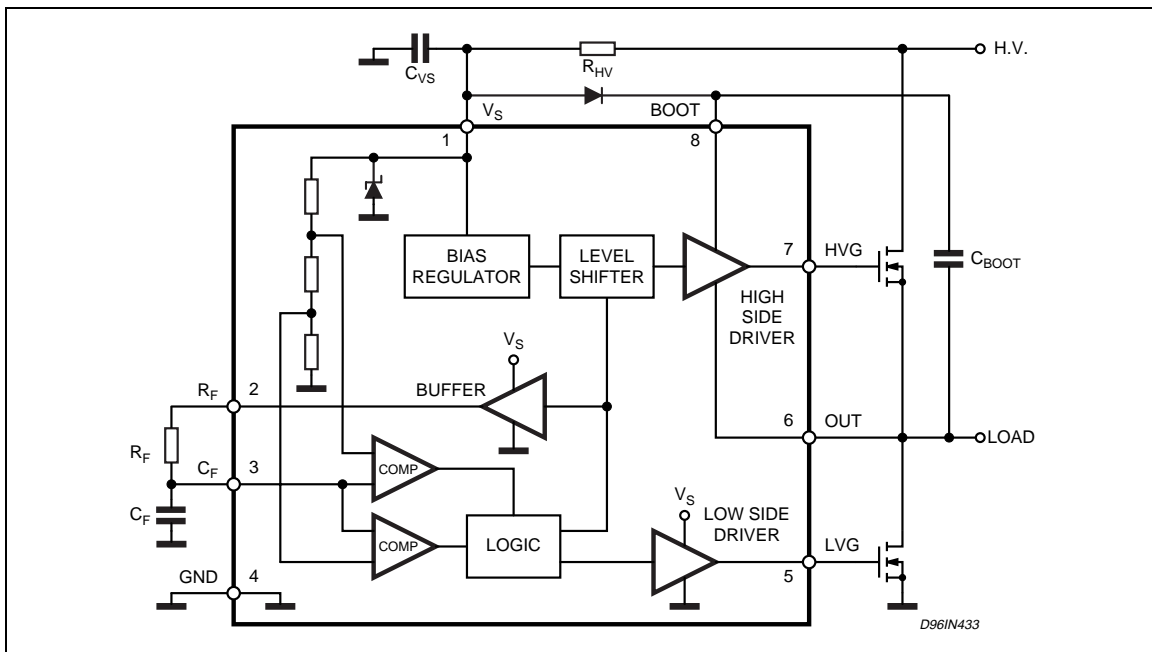

L6571A L6571B

ABSOLUTE MAXIMUM RATINGS

Symbol	Parameter	Value	Unit
I_S (*)	Supply Current	25	mA
V_{CF}	Oscillator Resistor Voltage	18	V
V_{LVG}	Low Side Switch Gate Output	14.6	V
V_{OUT}	High Side Switch Source Output	-1 to $V_{BOOT} - 18$	V
V_{HVG}	High Side Switch Gate Output	-1 to V_{BOOT}	V
V_{BOOT}	Floating Supply Voltage	618	V
$V_{BOOT/OUT}$	Floating Supply vs OUT Voltage	18	V
dV_{BOOT}/dt	VBOOT Slew Rate (Repetitive)	± 50	V/ns
dV_{OUT}/dt	VOUT Slew Rate (Repetitive)	± 50	V/ns
T_{stg}	Storage Temperature	-40 to 150	°C
T_j	Junction Temperature	-40 to 150	°C
T_{amb}	Ambient Temperature (Operative)	-40 to 125	°C

(*)The device has an internal zener clamp between GND and VS (typical 15.6V). Therefore the circuit should not be driven by a DC low impedance power source.

Note: ESD immunity for pins 6, 7 and 8 is guaranteed up to 900 V (Human Body Model)

THERMAL DATA

Symbol	Parameter	Minidip	SO8	Unit
$R_{th\ j-amb}$	Thermal Resistance Junction-Ambient Max	100	150	°C/W

RECOMMENDED OPERATING CONDITIONS

Symbol	Parameter	Min.	Max.	Unit
V_S	Supply Voltage	10	V_{CL}	V
V_{BOOT}	Floating Supply Voltage	-	500	V
V_{OUT}	High Side Switch Source Output	-1	$V_{BOOT} - V_{CL}$	V
f_{out}	Oscillation Frequency		200	kHz

PIN CONNECTION

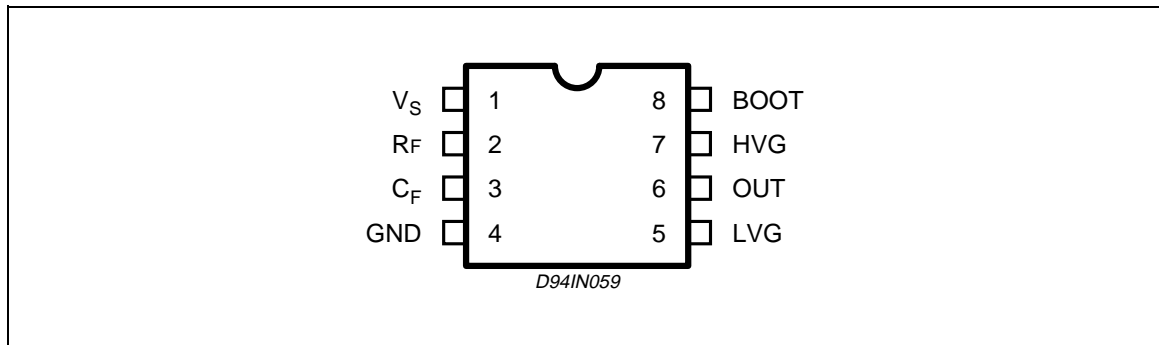

PIN FUNCTION

N°	Pin	Description
1	VS	Supply input voltage with internal clamp [typ. 15.6V]
2	RF	Oscillator timing resistor pin. A buffer set alternatively to V_S and GND can provide current to the external resistor RF connected between pin 2 and 3. Alternatively, the signal on pin 2 can be used also to drive another IC (i.e. another L6569/71 to drive a full H-bridge)
3	CF	Oscillator timing capacitor pin. A capacitor connected between this pin and GND fixes (together with R_F) the oscillating frequency Alternatively an external logic signal can be applied to the pin to drive the IC.
4	GND	Ground
5	LVG	Low side driver output. The output stage can deliver 170mA source and 270mA sink [typ.values].
6	OUT	Upper driver floating reference
7	HVG	High side driver output. The output stage can deliver 170mA source and 270mA sink [typ.values].
8	BOOT	Bootstrap voltage supply. It is the upper driver floating supply.

ELECTRICAL CHARACTERISTICS ($V_S = 12V$; $V_{BOOT} - V_{OUT} = 12V$; $T_j = 25^\circ C$; unless otherwise specified.)

Symbol	Pin	Parameter	Test Condition	Min.	Typ.	Max.	Unit
$V_{SUV P}$	1	VS Turn On Threshold		8.3	9	9.7	V
$V_{SUV N}$		VS Turn Off Threshold		7.3	8	8.7	V
$V_{SUV H}$		VS Hysteresis		0.7	1	1.3	V
V_{CL}		VS Clamping Voltage	$I_S = 5mA$	14.6	15.6	16.6	V
I_{SU}		Start Up Current	$V_S < V_{SUV N}$		150	250	μA
I_q		Quiescent Current	$V_S > V_{SUV P}$		500	700	μA
I_{BOOTLK}	8	Leakage Current BOOT pin vs GND	$V_{BOOT} = 580V$			5	μA
I_{OUTLK}	6	Leakage Current OUT pin vs GND	$V_{OUT} = 562V$			5	μA
$I_{HVG SO}$	7	High Side Driver Source Current	$V_{HVG} = 6V$	110	175		mA
$I_{HVG SI}$		High Side Driver Sink Current	$V_{HVG} = 6V$	190	275		mA
$I_{LVG SO}$	5	Low Side Driver Source Current	$V_{LVG} = 6V$	110	175		mA
$I_{LVG SI}$		Low Side Driver Sink Current	$V_{LVG} = 6V$	190	275		mA
$V_{RF ON}$	2	RF High Level Output Voltage	$I_{RF} = 1mA$	$V_S - 0.05$		$V_S - 0.2$	V
$V_{RF OFF}$		RF Low Level Output Voltage	$I_{RF} = -1mA$	50		200	mV
V_{CFU}	3	CF Upper Threshold		7.7	8	8.2	V
V_{CFL}		CF Lower Threshold		3.80	4	4.3	V
t_d		Internal Dead Time	L6571A L6571B	0.85 0.50	1.25 0.72	1.65 0.94	μs μs

ELECTRICAL CHARACTERISTICS (continued)

Symbol	Pin	Parameter	Test Condition	Min.	Typ.	Max.	Unit
DC		Duty Cycle, Ratio Between Dead Time + Conduction Time of High Side and Low Side Drivers		0.45	0.5	0.55	
I _{AVE}	1	Average Current from Vs	No Load, fs = 60KHz		1.2	1.5	mA
f _{out}	6	Oscillation Frequency	R _T = 12K; C _T = 1nF	57	60	63	kHz

OSCILLATOR FREQUENCY

The frequency of the internal oscillator can be programmed using external resistor and capacitor.

The nominal oscillator frequency can be calculated using the following equation:

$$f_{OSC} = \frac{1}{2 \cdot R_F \cdot C_F \cdot \ln 2} = \frac{1}{1.3863 \cdot R_F \cdot C_F}$$

Where R_F and C_F are the external resistor and capacitor.

The device can be driven in "shut down" condition keeping the C_F pin close to GND, but some cares have to be taken:

1. When C_F is to GND the high side driver is off and the low side is on
2. The forced discharge of the oscillator capacitor C_F must not be shorter than 1us: a simple way to do this is to limit the current discharge with a resistive path imposing R · C_F > 1μs (see fig.1)

Figure 1.

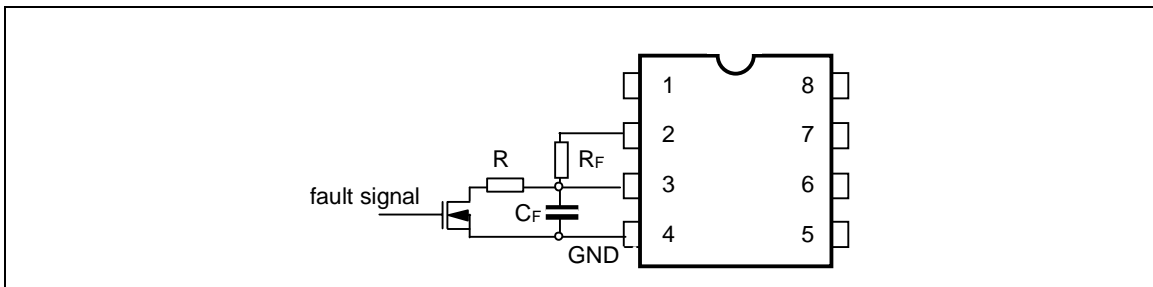

Figure 2. Waveforms

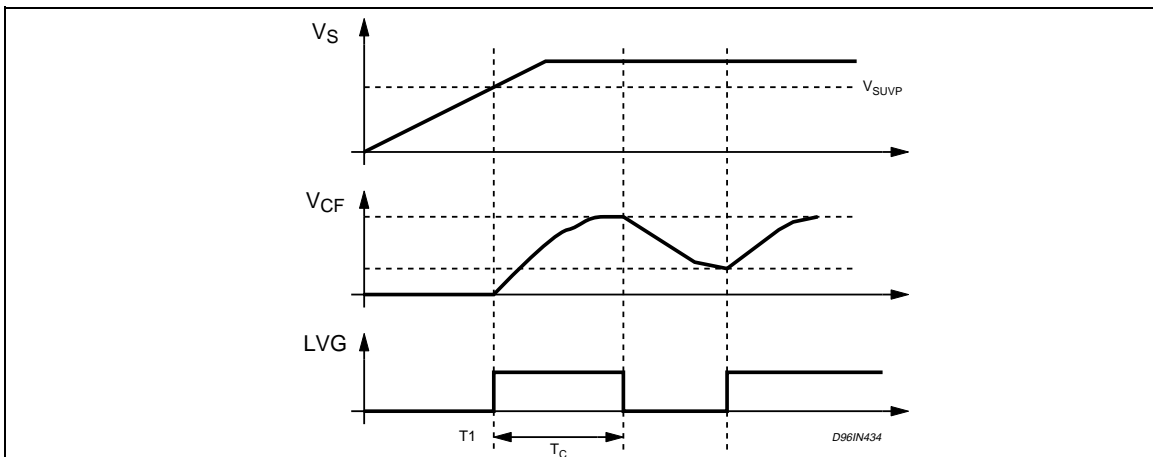

Figure 3. Typical Dead Time vs. Temperature Dependency (L6571A)

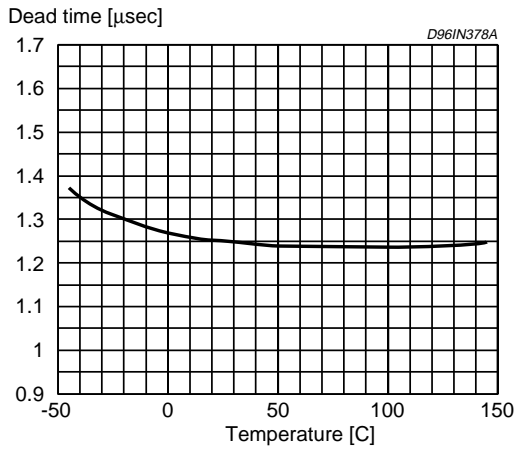

Figure 6. Typical Rise and Fall Times vs. Load Capacitance

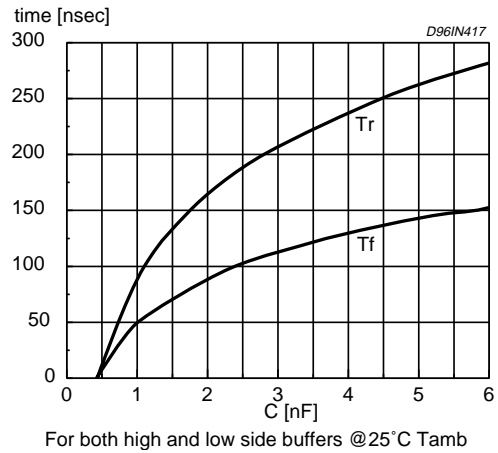

Figure 4. Typical Frequency vs Temperature Dependency

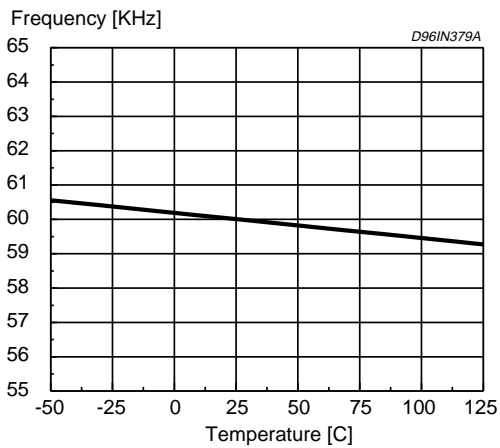

Figure 7. Quiescent Current vs. Supply Voltage.

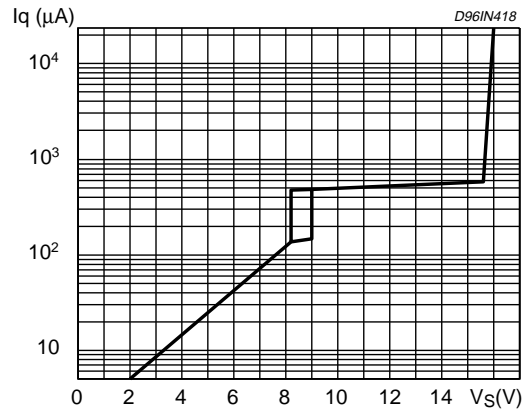
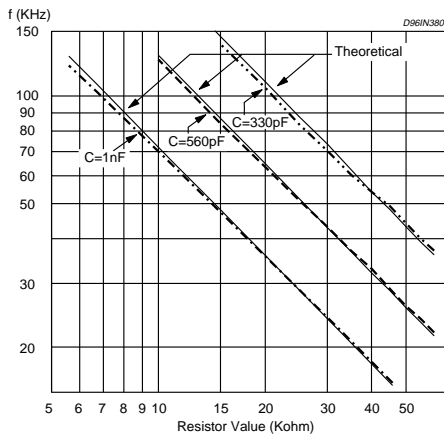

Figure 5. Typical and Theoretical Oscillator Frequency vs Resistor Value



L6571A L6571B

DIM.	mm			inch		
	MIN.	TYP.	MAX.	MIN.	TYP.	MAX.
A			1.75			0.069
a1	0.1		0.25	0.004		0.010
a2			1.65			0.065
a3	0.65		0.85	0.026		0.033
b	0.35		0.48	0.014		0.019
b1	0.19		0.25	0.007		0.010
C	0.25		0.5	0.010		0.020
c1	45° (typ.)					
D (1)	4.8		5.0	0.189		0.197
E	5.8		6.2	0.228		0.244
e		1.27			0.050	
e3		3.81			0.150	
F (1)	3.8		4.0	0.15		0.157
L	0.4		1.27	0.016		0.050
M			0.6			0.024
S	8° (max.)					

OUTLINE AND MECHANICAL DATA

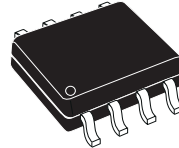

SO8

(1) D and F do not include mold flash or protrusions. Mold flash or protrusions shall not exceed 0.15mm (.006inch).

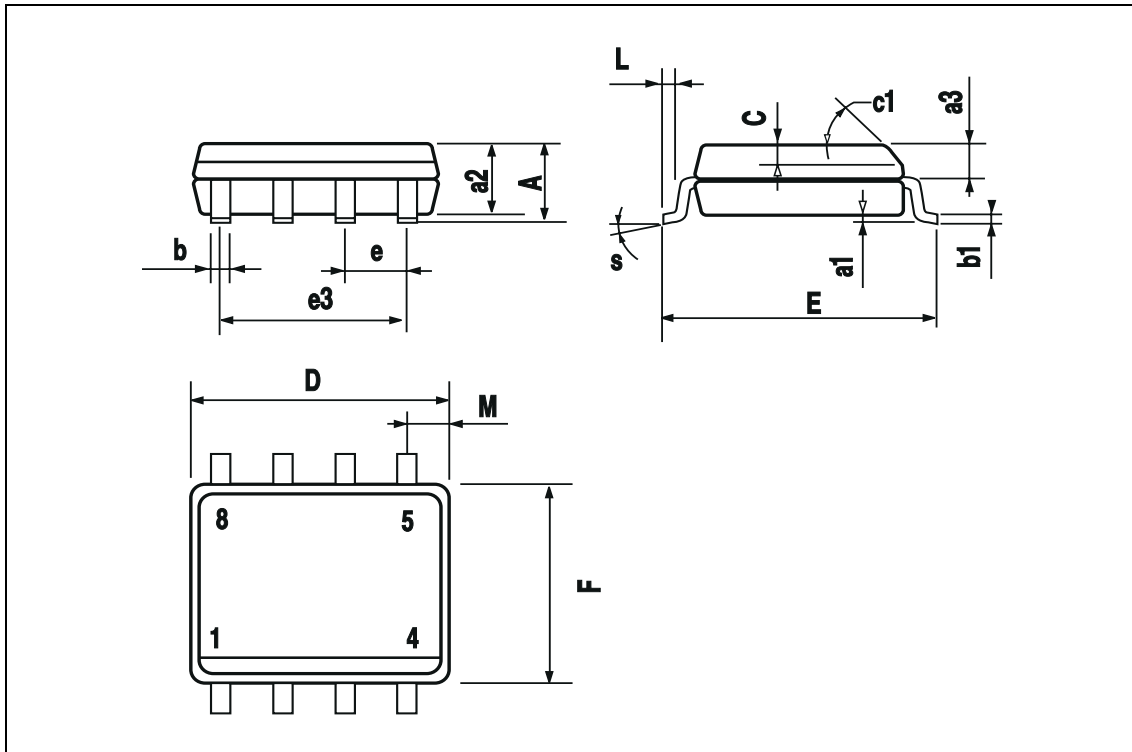

DIM.	mm			inch		
	MIN.	TYP.	MAX.	MIN.	TYP.	MAX.
A		3.32			0.131	
a1	0.51			0.020		
B	1.15		1.65	0.045		0.065
b	0.356		0.55	0.014		0.022
b1	0.204		0.304	0.008		0.012
D			10.92			0.430
E	7.95		9.75	0.313		0.384
e		2.54			0.100	
e3		7.62			0.300	
e4		7.62			0.300	
F			6.6			0.260
I			5.08			0.200
L	3.18		3.81	0.125		0.150
Z			1.52			0.060

OUTLINE AND MECHANICAL DATA

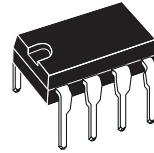

Minidip

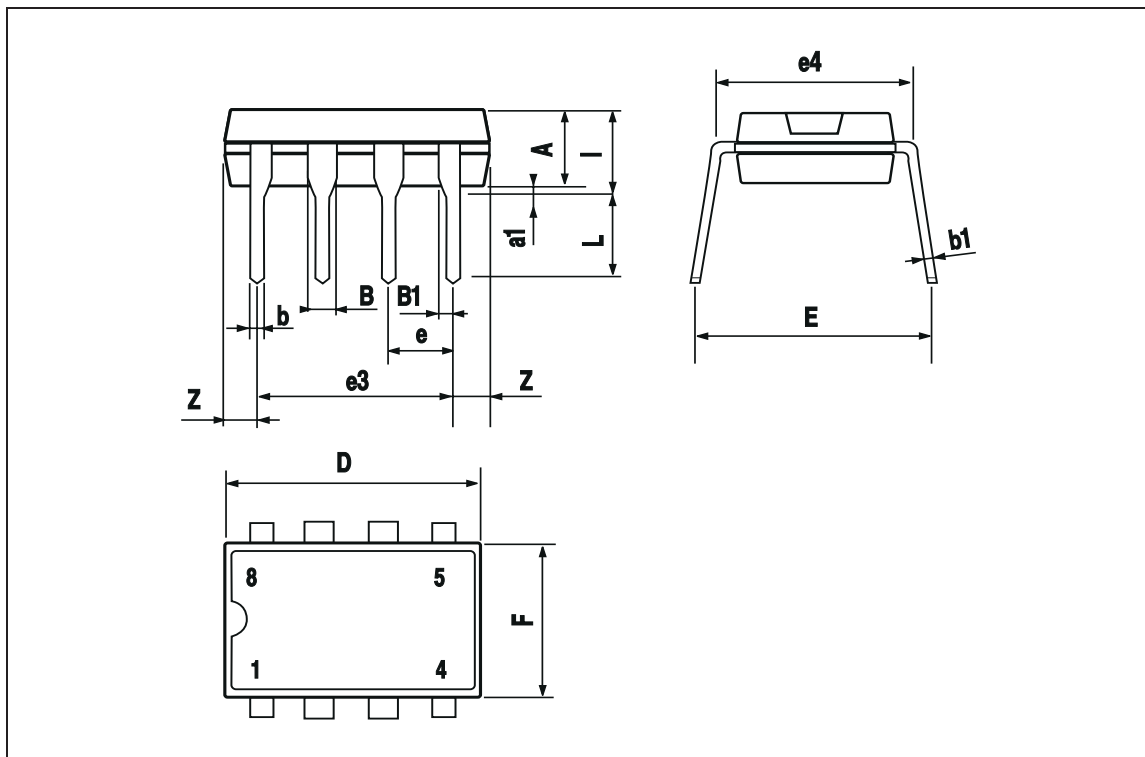

Information furnished is believed to be accurate and reliable. However, STMicroelectronics assumes no responsibility for the consequences of use of such information nor for any infringement of patents or other rights of third parties which may result from its use. No license is granted by implication or otherwise under any patent or patent rights of STMicroelectronics. Specifications mentioned in this publication are subject to change without notice. This publication supersedes and replaces all information previously supplied. STMicroelectronics products are not authorized for use as critical components in life support devices or systems without express written approval of STMicroelectronics.

The ST logo is a registered trademark of STMicroelectronics
© 2000 STMicroelectronics - All Rights Reserved

STMicroelectronics GROUP OF COMPANIES
Australia - Brazil - China - Finland - France - Germany - Hong Kong - India - Italy - Japan - Malaysia - Malta - Morocco - Singapore - Spain
- Sweden - Switzerland - United Kingdom - U.S.A.
<http://www.st.com>

