

MC7900 Series

1.0 A Negative Voltage Regulators

The MC7900 series of fixed output negative voltage regulators are intended as complements to the popular MC7800 series devices. These negative regulators are available in the same seven-voltage options as the MC7800 devices. In addition, one extra voltage option commonly employed in MECL systems is also available in the negative MC7900 series.

Available in fixed output voltage options from -5.0 V to -24 V , these regulators employ current limiting, thermal shutdown, and safe-area compensation – making them remarkably rugged under most operating conditions. With adequate heatsinking they can deliver output currents in excess of 1.0 A.

- No External Components Required
- Internal Thermal Overload Protection
- Internal Short Circuit Current Limiting
- Output Transistor Safe-Area Compensation
- Available in 2% Voltage Tolerance (See Ordering Information)
- Pb-Free Package May be Available. The G-Suffix Denotes a Pb-Free Lead Finish

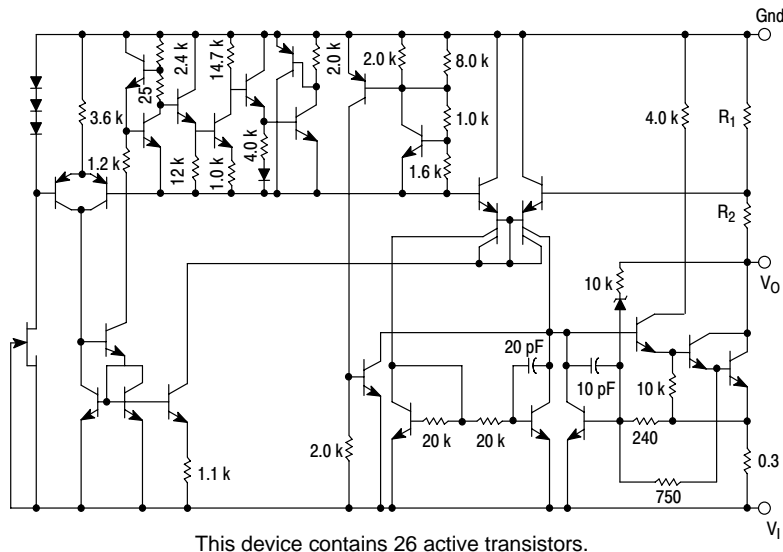

Figure 1. Representative Schematic Diagram



ON Semiconductor®

TO-220
T SUFFIX
CASE 221AB

Heatsink surface
connected to Pin 2.

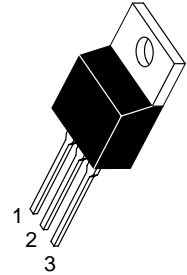

Pin 1. Ground
2. Input
3. Output

D²PAK
D2T SUFFIX
CASE 936

Heatsink surface (shown as terminal 4 in
case outline drawing) is connected to Pin 2.

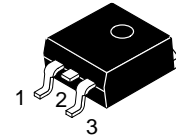

STANDARD APPLICATION

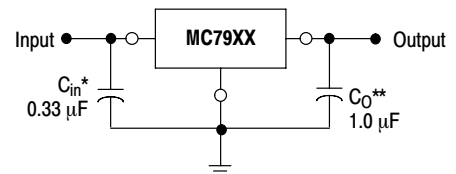

A common ground is required between the input and the output voltages. The input voltage must remain typically 2.0 V above more negative even during the high point of the input ripple voltage.

XX, These two digits of the type number indicate nominal voltage.

* C_{in} is required if regulator is located an appreciable distance from power supply filter.

** C_o improve stability and transient response.

ORDERING INFORMATION

See detailed ordering and shipping information in the package dimensions section on page 11 of this data sheet.

DEVICE MARKING INFORMATION

See general marking information in the device marking section on page 14 of this data sheet.

MC7900 Series

MAXIMUM RATINGS ($T_A = +25^\circ\text{C}$, unless otherwise noted.)

Rating	Symbol	Value	Unit
Input Voltage ($-5.0\text{ V} \geq V_O \geq -18\text{ V}$) (24 V)	V_I	-35 -40	Vdc
Power Dissipation Case 221A $T_A = +25^\circ\text{C}$ Thermal Resistance, Junction-to-Ambient Thermal Resistance, Junction-to-Case Case 936 (D ² PAK) $T_A = +25^\circ\text{C}$ Thermal Resistance, Junction-to-Ambient Thermal Resistance, Junction-to-Case	P_D θ_{JA} θ_{JC} P_D θ_{JA} θ_{JC}	Internally Limited 65 5.0 Internally Limited 70 5.0	W $^\circ\text{C/W}$ $^\circ\text{C/W}$ W $^\circ\text{C/W}$ $^\circ\text{C/W}$
Storage Junction Temperature Range	T_{stg}	-65 to +150	$^\circ\text{C}$
Junction Temperature	T_J	+150	$^\circ\text{C}$

Stresses exceeding Maximum Ratings may damage the device. Maximum Ratings are stress ratings only. Functional operation above the Recommended Operating Conditions is not implied. Extended exposure to stresses above the Recommended Operating Conditions may affect device reliability.

*This device series contains ESD protection and exceeds the following tests:

Human Body Model 2000 V per MIL_STD_883, Method 3015
Machine Model Method 200 V

MC7905B, MC7905C

ELECTRICAL CHARACTERISTICS ($V_I = -10\text{ V}$, $I_O = 500\text{ mA}$, $T_{low}^* < T_J < +125^\circ\text{C}$, unless otherwise noted.)

Characteristics	Symbol	Min	Typ	Max	Unit
Output Voltage ($T_J = +25^\circ\text{C}$)	V_O	-4.8	-5.0	-5.2	Vdc
Line Regulation (Note 1) ($T_J = +25^\circ\text{C}$, $I_O = 100\text{ mA}$) $-7.0\text{ Vdc} \geq V_I \geq -25\text{ Vdc}$ $-8.0\text{ Vdc} \geq V_I \geq -12\text{ Vdc}$ ($T_J = +25^\circ\text{C}$, $I_O = 500\text{ mA}$) $-7.0\text{ Vdc} \geq V_I \geq -25\text{ Vdc}$ $-8.0\text{ Vdc} \geq V_I \geq -12\text{ Vdc}$	Reg_{line}	- - -	7.0 2.0 35 8.0	50 25 100 50	mV
Load Regulation, $T_J = +25^\circ\text{C}$ (Note 1) $5.0\text{ mA} \leq I_O \leq 1.5\text{ A}$ $250\text{ mA} \leq I_O \leq 750\text{ mA}$	Reg_{load}	- -	11 4.0	100 50	mV
Output Voltage $-7.0\text{ Vdc} \geq V_I \geq -20\text{ Vdc}$, $5.0\text{ mA} \leq I_O \leq 1.0\text{ A}$, $P \leq 15\text{ W}$	V_O	-4.75	-	-5.25	Vdc
Input Bias Current ($T_J = +25^\circ\text{C}$)	I_{IB}	-	4.3	8.0	mA
Input Bias Current Change $-7.0\text{ Vdc} \geq V_I \geq -25\text{ Vdc}$ $5.0\text{ mA} \leq I_O \leq 1.5\text{ A}$	ΔI_{IB}	- -	- -	1.3 0.5	mA
Output Noise Voltage ($T_A = +25^\circ\text{C}$, $10\text{ Hz} \leq f \leq 100\text{ kHz}$)	V_n	-	40	-	μV
Ripple Rejection ($I_O = 20\text{ mA}$, $f = 120\text{ Hz}$)	RR	-	70	-	dB
Dropout Voltage $I_O = 1.0\text{ A}$, $T_J = +25^\circ\text{C}$	$V_I - V_O$	-	1.3	-	Vdc
Average Temperature Coefficient of Output Voltage $I_O = 5.0\text{ mA}$, $T_{low}^* \leq T_J \leq +125^\circ\text{C}$	$\Delta V_O / \Delta T$	-	-1.0	-	$\text{mV}/^\circ\text{C}$

1. Load and line regulation are specified at constant junction temperature. Changes in V_O due to heating effects must be taken into account separately. Pulse testing with low duty cycle is used.

* $T_{low} = -40^\circ\text{C}$ for MC7905B and $T_{low} = 0^\circ\text{C}$ for MC7905C.

MC7900 Series

MC7918C

ELECTRICAL CHARACTERISTICS ($V_I = -27\text{ V}$, $I_O = 500\text{ mA}$, $0^\circ\text{C} < T_J < +125^\circ\text{C}$, unless otherwise noted.)

Characteristics	Symbol	Min	Typ	Max	Unit
Output Voltage ($T_J = +25^\circ\text{C}$)	V_O	-17.3	-18	-18.7	Vdc
Line Regulation (Note 6) ($T_J = +25^\circ\text{C}$, $I_O = 100\text{ mA}$) -21 Vdc $\geq V_I \geq -33\text{ Vdc}$ -24 Vdc $\geq V_I \geq -30\text{ Vdc}$ ($T_J = +25^\circ\text{C}$, $I_O = 500\text{ mA}$) -21 Vdc $\geq V_I \geq -33\text{ Vdc}$ -24 Vdc $\geq V_I \geq -30\text{ Vdc}$	Reg_{line}	-	25 10	180 90	mV
Load Regulation, $T_J = +25^\circ\text{C}$ (Note 6) $5.0\text{ mA} \leq I_O \leq 1.5\text{ A}$ $250\text{ mA} \leq I_O \leq 750\text{ mA}$	Reg_{load}	-	110 55	360 180	mV
Output Voltage -21 Vdc $\geq V_I \geq -33\text{ Vdc}$, $5.0\text{ mA} \leq I_O \leq 1.0\text{ A}$, $P \leq 15\text{ W}$	V_O	-17.1	-	-18.9	Vdc
Input Bias Current ($T_J = +25^\circ\text{C}$)	I_{IB}	-	4.5	8.0	mA
Input Bias Current Change -21 Vdc $\geq V_I \geq -33\text{ Vdc}$ $5.0\text{ mA} \leq I_O \leq 1.5\text{ A}$	ΔI_{IB}	-	-	1.0 0.5	mA
Output Noise Voltage ($T_A = +25^\circ\text{C}$, $10\text{ Hz} \leq f \leq 100\text{ kHz}$)	V_n	-	110	-	μV
Ripple Rejection ($I_O = 20\text{ mA}$, $f = 120\text{ Hz}$)	RR	-	59	-	dB
Dropout Voltage ($I_O = 1.0\text{ A}$, $T_J = +25^\circ\text{C}$)	$V_I - V_O$	-	1.3	-	Vdc
Average Temperature Coefficient of Output Voltage $I_O = 5.0\text{ mA}$, $0^\circ\text{C} \leq T_J \leq +125^\circ\text{C}$	$\Delta V_O / \Delta T$	-	-1.0	-	$\text{mV}/^\circ\text{C}$

MC7924B, MC7924C

ELECTRICAL CHARACTERISTICS ($V_I = -33\text{ V}$, $I_O = 500\text{ mA}$, $T_{\text{low}}^* < T_J < +125^\circ\text{C}$, unless otherwise noted.)

Characteristics	Symbol	Min	Typ	Max	Unit
Output Voltage ($T_J = +25^\circ\text{C}$)	V_O	-23	-24	-25	Vdc
Line Regulation (Note 6) ($T_J = +25^\circ\text{C}$, $I_O = 100\text{ mA}$) -27 Vdc $\geq V_I \geq -38\text{ Vdc}$ -30 Vdc $\geq V_I \geq -36\text{ Vdc}$ ($T_J = +25^\circ\text{C}$, $I_O = 500\text{ mA}$) -27 Vdc $\geq V_I \geq -38\text{ Vdc}$ -30 Vdc $\geq V_I \geq -36\text{ Vdc}$	Reg_{line}	-	31 14	240 120	mV
Load Regulation, $T_J = +25^\circ\text{C}$ (Note 6) $5.0\text{ mA} \leq I_O \leq 1.5\text{ A}$ $250\text{ mA} \leq I_O \leq 750\text{ mA}$	Reg_{load}	-	150 85	480 240	mV
Output Voltage -27 Vdc $\geq V_I \geq -38\text{ Vdc}$, $5.0\text{ mA} \leq I_O \leq 1.0\text{ A}$, $P \leq 15\text{ W}$	V_O	-22.8	-	-25.2	Vdc
Input Bias Current ($T_J = +25^\circ\text{C}$)	I_{IB}	-	4.6	8.0	mA
Input Bias Current Change -27 Vdc $\geq V_I \geq -38\text{ Vdc}$ $5.0\text{ mA} \leq I_O \leq 1.5\text{ A}$	ΔI_{IB}	-	-	1.0 0.5	mA
Output Noise Voltage ($T_A = +25^\circ\text{C}$, $10\text{ Hz} \leq f \leq 100\text{ kHz}$)	V_n	-	170	-	μV
Ripple Rejection ($I_O = 20\text{ mA}$, $f = 120\text{ Hz}$)	RR	-	56	-	dB
Dropout Voltage ($I_O = 1.0\text{ A}$, $T_J = +25^\circ\text{C}$)	$V_I - V_O$	-	1.3	-	Vdc
Average Temperature Coefficient of Output Voltage $I_O = 5.0\text{ mA}$, $T_{\text{low}}^* \leq T_J \leq +125^\circ\text{C}$	$\Delta V_O / \Delta T$	-	-1.0	-	$\text{mV}/^\circ\text{C}$

6. Load and line regulation are specified at constant junction temperature. Changes in V_O due to heating effects must be taken into account separately. Pulse testing with low duty cycle is used.

* $T_{\text{low}} = -40^\circ\text{C}$ for MC7924B and $T_{\text{low}} = 0^\circ\text{C}$ for MC7924C.

MC7900 Series

Device	Nominal Output Voltage	Output Voltage Tolerance	Package	Operating Temperature Range	Shipping†
MC7918CT	- 18 V	4%	TO-220	$T_J = 0^{\circ}\text{C}$ to $+125^{\circ}\text{C}$	50 Units/Rail
MC7918CTG			TO-220 (Pb-Free)		50 Units/Rail
MC7924BT	- 24 V	4%	TO-220	$T_J = -40^{\circ}\text{C}$ to $+125^{\circ}\text{C}$	50 Units/Rail
MC7924BTG			TO-220 (Pb-Free)		50 Units/Rail
MC7924CD2T			D ² PAK	$T_J = 0^{\circ}\text{C}$ to $+125^{\circ}\text{C}$	50 Units/Rail
MC7924CD2TG			D ² PAK (Pb-Free)		50 Units/Rail
MC7924CT			TO-220		50 Units/Rail
MC7924CTG			TO-220 (Pb-Free)		50 Units/Rail

†For information on tape and reel specifications, including part orientation and tape sizes, please refer to our Tape and Reel Packaging Specifications Brochure, BRD8011/D.

MC7900 Series

PACKAGE DIMENSIONS

TO-220, SINGLE GAUGE
T SUFFIX
CASE 221AB-01
ISSUE O

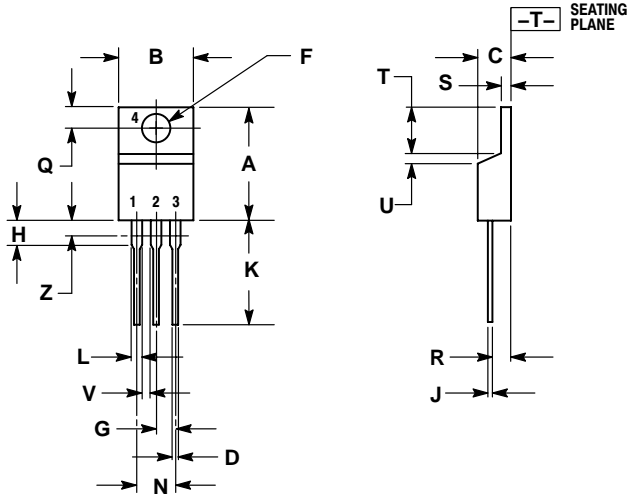

NOTES:

1. DIMENSIONING AND TOLERANCING PER ANSI Y14.5M, 1982.
2. CONTROLLING DIMENSION: INCH.
3. DIMENSION Z DEFINES A ZONE WHERE ALL BODY AND LEAD IRREGULARITIES ARE ALLOWED.

DIM	INCHES		MILLIMETERS	
	MIN	MAX	MIN	MAX
A	0.570	0.620	14.48	15.75
B	0.380	0.405	9.66	10.28
C	0.160	0.190	4.07	4.82
D	0.025	0.035	0.64	0.88
F	0.142	0.147	3.61	3.73
G	0.095	0.105	2.42	2.66
H	0.110	0.155	2.80	3.93
J	0.018	0.025	0.46	0.64
K	0.500	0.562	12.70	14.27
L	0.045	0.060	1.15	1.52
N	0.190	0.210	4.83	5.33
Q	0.100	0.120	2.54	3.04
R	0.080	0.110	2.04	2.79
S	0.020	0.055	0.508	1.39
T	0.235	0.255	5.97	6.47
U	0.000	0.050	0.00	1.27
V	0.045	---	1.15	---
Z	---	0.080	---	2.04