

Positive voltage regulators

Features

- Output current to 1.5 A
- Output voltages of 5; 6; 8; 8.5; 9; 12; 15; 18; 24 V
- Thermal overload protection
- Short circuit protection
- Output transition SOA protection

Description

The L78xx series of three-terminal positive regulators is available in TO-220, TO-220FP, TO-3, D²PAK and DPAK packages and several fixed output voltages, making it useful in a wide range of applications. These regulators can provide local on-card regulation, eliminating the distribution problems associated with single point regulation. Each type employs internal current limiting, thermal shut-down and safe area protection, making it essentially indestructible. If adequate heat sinking is provided, they can deliver over 1 A output current. Although designed primarily as fixed voltage regulators, these devices can be used with external components to obtain adjustable voltage and currents.

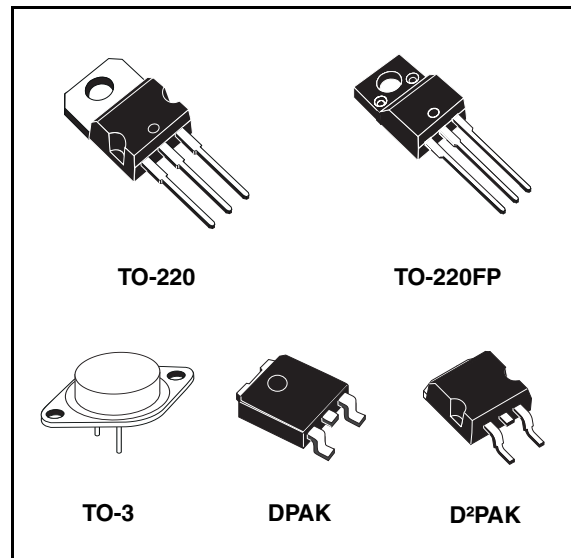

Table 1. Device summary

Part numbers	
L7805	L7809C
L7805C	L7812C
L7806C	L7815C
L7808C	L7818C
L7885C	L7824C

3 Maximum ratings

Table 2. Absolute maximum ratings

Symbol	Parameter		Value	Unit
V_I	DC input voltage	for $V_O = 5$ to 18 V	35	V
		for $V_O = 20, 24$ V	40	
I_O	Output current		Internally limited	
P_D	Power dissipation		Internally limited	
T_{STG}	Storage temperature range		-65 to 150	°C
T_{OP}	Operating junction temperature range	for L7800	-55 to 150	°C
		for L7800C	0 to 150	

Note: Absolute maximum ratings are those values beyond which damage to the device may occur. Functional operation under these condition is not implied.

Table 3. Thermal data

Symbol	Parameter	D ² PAK	DPAK	TO-220	TO-220FP	TO-3	Unit
R_{thJC}	Thermal resistance junction-case	3	8	5	5	4	°C/W
R_{thJA}	Thermal resistance junction-ambient	62.5	100	50	60	35	°C/W

Figure 4. Application circuits

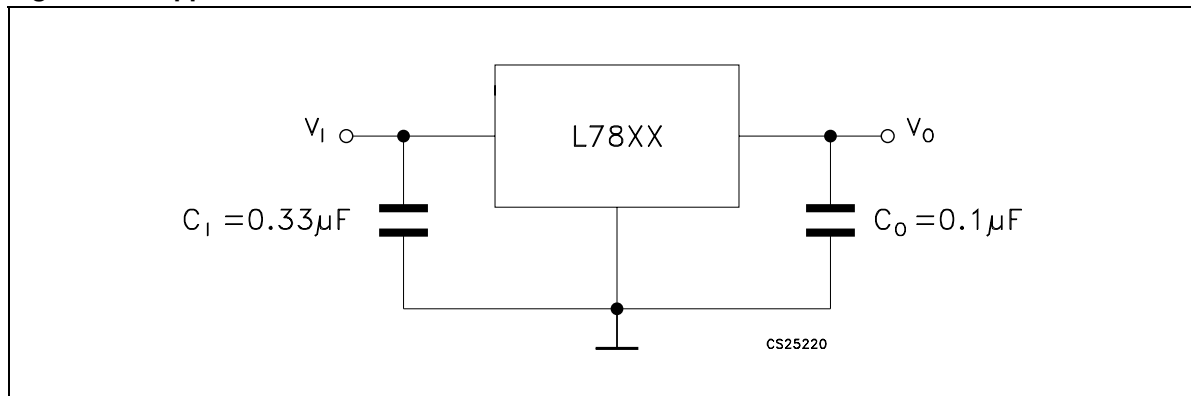

Table 14. Electrical characteristics of L7806C (refer to the test circuits, $T_J = 0$ to 150 °C, $V_I = 11$ V, $I_O = 500$ mA, $C_I = 0.33$ μ F, $C_O = 0.1$ μ F unless otherwise specified)

Symbol	Parameter	Test conditions	Min.	Typ.	Max.	Unit
V_O	Output voltage	$T_J = 25^\circ\text{C}$	5.75	6	6.25	V
V_O	Output voltage	$I_O = 5$ mA to 1 A, $P_O \leq 15$ W $V_I = 8$ to 21 V	5.7	6	6.3	V
$\Delta V_O^{(1)}$	Line regulation	$V_I = 8$ to 25 V, $T_J = 25^\circ\text{C}$			120	mV
		$V_I = 9$ to 13 V, $T_J = 25^\circ\text{C}$			60	
$\Delta V_O^{(1)}$	Load regulation	$I_O = 5$ mA to 1.5 A, $T_J = 25^\circ\text{C}$			120	mV
		$I_O = 250$ to 750 mA, $T_J = 25^\circ\text{C}$			60	
I_d	Quiescent current	$T_J = 25^\circ\text{C}$			8	mA
ΔI_d	Quiescent current change	$I_O = 5$ mA to 1 A			0.5	mA
		$V_I = 8$ to 25 V			1.3	
$\Delta V_O/\Delta T$	Output voltage drift	$I_O = 5$ mA		-0.8		mV/°C
eN	Output noise voltage	$B = 10$ Hz to 100 kHz, $T_J = 25^\circ\text{C}$		45		$\mu\text{V}/V_O$
SVR	Supply voltage rejection	$V_I = 9$ to 19 V, $f = 120$ Hz	59			dB
V_d	Dropout voltage	$I_O = 1$ A, $T_J = 25^\circ\text{C}$		2		V
R_O	Output resistance	$f = 1$ kHz		19		m Ω
I_{sc}	Short circuit current	$V_I = 35$ V, $T_J = 25^\circ\text{C}$		0.55		A
I_{scp}	Short circuit peak current	$T_J = 25^\circ\text{C}$		2.2		A

1. Load and line regulation are specified at constant junction temperature. Changes in V_O due to heating effects must be taken into account separately. Pulse testing with low duty cycle is used.

Figure 38. Drawing dimension TO-220 (type SMIC-subcon.)

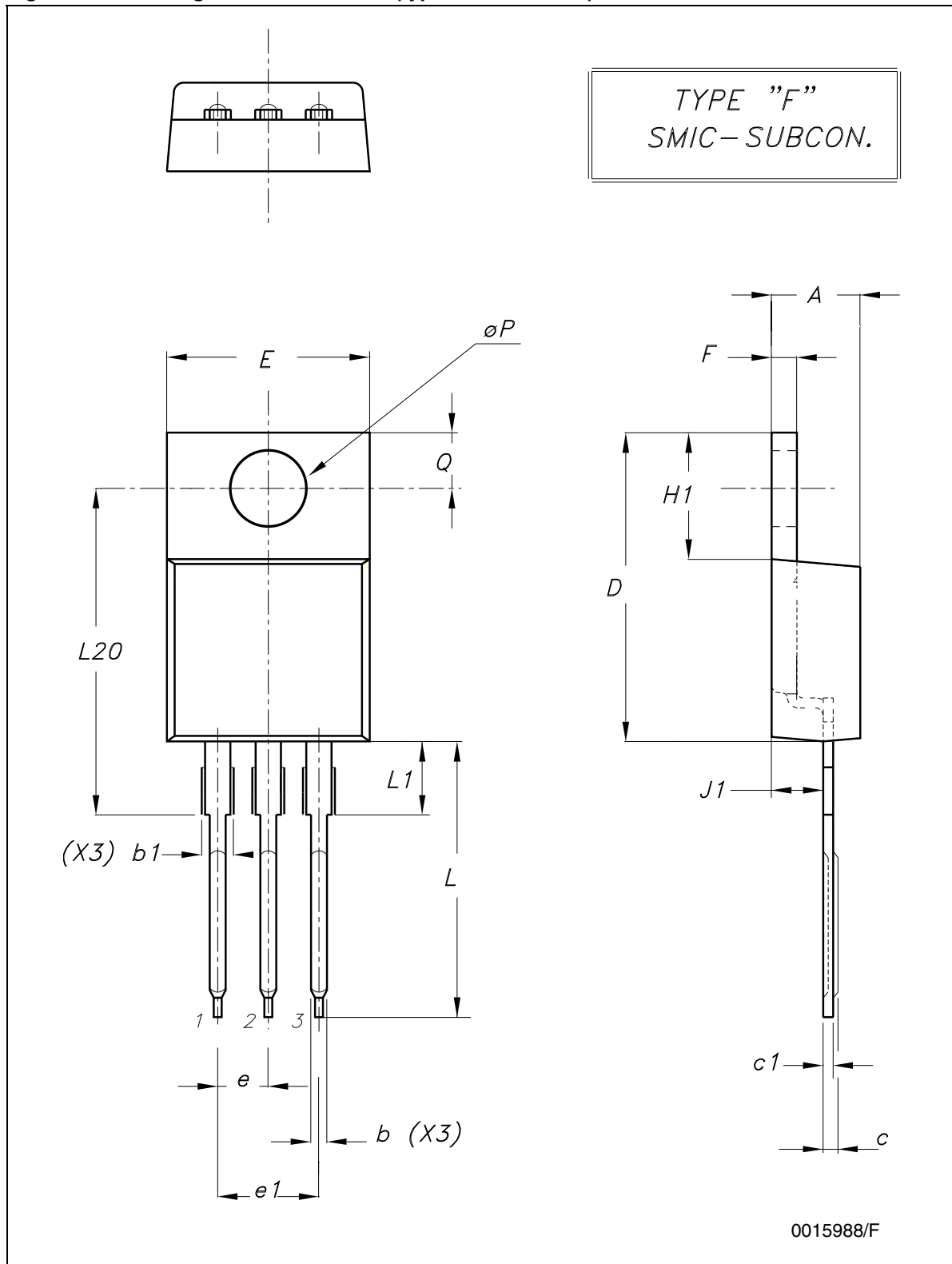

Figure 39. Drawing dimension TO-220 (type STD-ST)

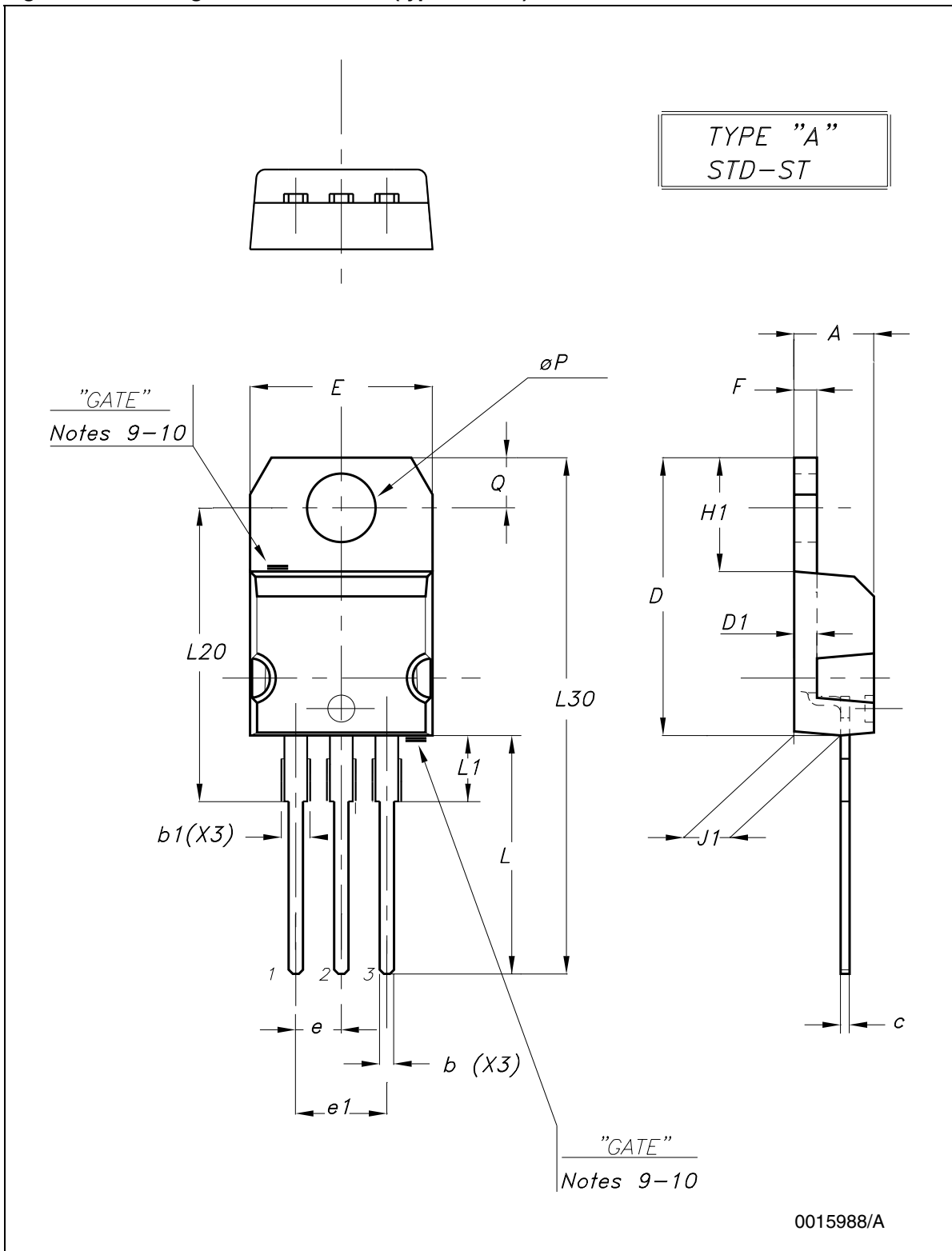

Table 24. TO-220 mechanical data

Dim.	Type STD-ST			Type SMIC-Subcon.		
	mm.			mm.		
	Min.	Typ.	Max.	Min.	Typ.	Max.
A	4.40		4.60	4.47	4.57	4.67
A1	0.61		0.88	0.80	0.81	0.86
b1	1.14		1.70	1.15		1.44
c	0.49		0.70		0.56	
c1					0.38	
D	15.25		15.75	15.07	15.24	15.45
D1		1.27				
E	10.00		10.40	10	10.15	10.30
e	2.40		2.70	2.29	2.54	2.79
e1	4.95		5.15	4.83	5.08	5.33
F	1.23		1.32		1.27	
H1	6.20		6.60		6.24	
J1	2.40		2.72	2.04	2.67	2.92
L	13.00		14.00	13.35	13.50	13.65
L1	3.50		3.93		3.90	
L20		16.40		16.25	16.40	16.55
L30		28.90			28.74	
ØP	3.75		3.85		3.83	
Q	2.65		2.95	2.72	2.74	2.80

Note: In spite of some difference in tolerances, the packages are compatible.

8 Order codes

Table 32. Order codes

Part numbers	Order codes				
	TO-220	DPAK	D ² PAK	TO-220FP	TO-3
L7805					L7805T
L7805C	L7805CV	L7805CDT-TR	L7805CD2T-TR	L7805CP	L7805CT
L7806C	L7806CV		L7806CD2T-TR		L7806CT
L7808C	L7808CV		L7808CD2T-TR	L7808CP	
L7885C	L7885CV		L7885CD2T-TR ⁽¹⁾	L7885CP ⁽¹⁾	L7885CT ⁽¹⁾
L7809C	L7809CV		L7809CD2T-TR	L7809CP	
L7812C	L7812CV		L7812CD2T-TR	L7812CP	L7812CT
L7815C	L7815CV		L7815CD2T-TR	L7815CP	L7815CT
L7818C	L7818CV		L7818CD2T-TR ⁽¹⁾		L7818CT
L7824C	L7824CV		L7824CD2T-TR	L7824CP	L7824CT

1. Available on request.