

Positive voltage regulators

Features

- Output current to 0.5 A
- Output voltages of 5; 6; 8; 9; 12; 15; 24 V
- Thermal overload protection
- Short circuit protection
- Output transition SOA protection

Description

The L78Mxx series of three-terminal positive regulators is available in TO-220, TO-220FP, DPAK and IPAK packages and with several fixed output voltages, making it useful in a wide range of applications. These regulators can provide local on-card regulation, eliminating the distribution problems associated with single point regulation. Each type employs internal current limiting, thermal shut-down and safe area protection, making it essentially indestructible. If adequate heat sinking is provided, they can deliver over 0.5 A output current. Although designed primarily as fixed voltage regulators, these devices can be used with external components to obtain adjustable voltage and currents.

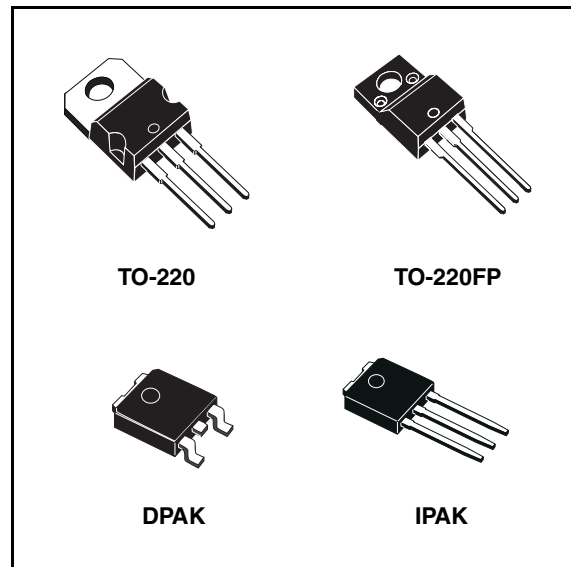

Table 1. Device summary

Part numbers	
L78M05C	L78M12C
L78M06C	L78M15C
L78M08C	L78M24C
L78M09C	

3 Maximum ratings

Table 2. Absolute maximum ratings

Symbol	Parameter	Value	Unit
V_I	DC input voltage	for $V_O= 5$ to $18V$	35
		for $V_O= 20, 24V$	40
I_O	Output current	Internally limited	mA
P_D	Power dissipation	Internally limited	mW
T_{STG}	Storage temperature range	-65 to 150	°C
T_{OP}	Operating junction temperature range	0 to 150	°C

Note: Absolute maximum ratings are those values beyond which damage to the device may occur. Functional operation under these condition is not implied

Table 3. Thermal data

Symbol	Parameter	TO-220	TO-220FP	DPAK	IPAK	Unit
R_{thJC}	Thermal resistance junction-case	3	5	8		°C/W
R_{thJA}	Thermal resistance junction-ambient	50	60	100		°C/W

Figure 4. Application circuit

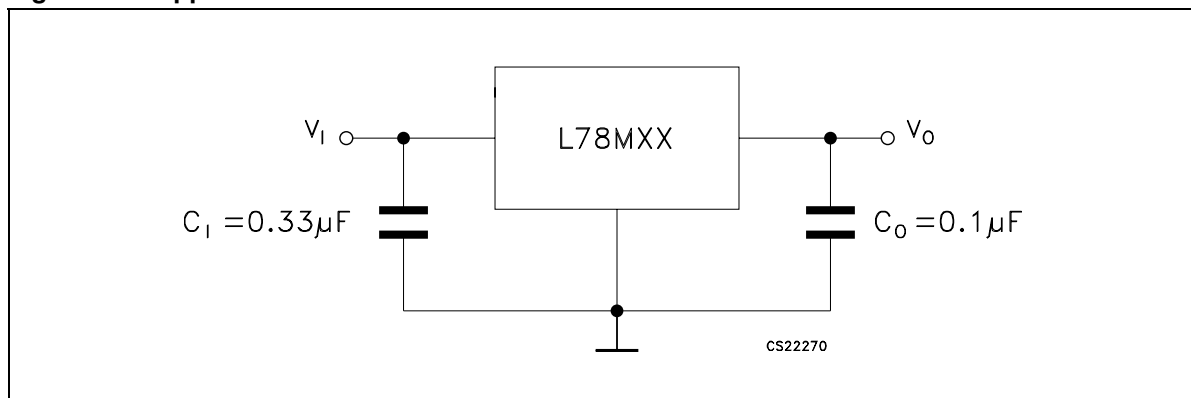

Table 8. Electrical characteristics of L78M12C (refer to the test circuits, $T_J = 25\text{ }^\circ\text{C}$, $V_I = 19\text{ V}$, $I_O = 350\text{ mA}$, $C_I = 0.33\text{ }\mu\text{F}$, $C_O = 0.1\text{ }\mu\text{F}$ unless otherwise specified)

Symbol	Parameter	Test conditions	Min.	Typ.	Max.	Unit
V_O	Output voltage		11.5	12	12.5	V
V_O	Output voltage	$I_O = 5\text{ to }350\text{ mA}$, $V_I = 14.5\text{ to }27\text{ V}$	11.4	12	12.6	V
ΔV_O	Line regulation	$V_I = 14.5\text{ to }30\text{ V}$, $I_O = 200\text{ mA}$			100	mV
		$V_I = 16\text{ to }30\text{ V}$, $I_O = 200\text{ mA}$			50	
ΔV_O	Load regulation	$I_O = 5\text{ to }500\text{ mA}$, $T_J = 25\text{ }^\circ\text{C}$			240	mV
		$I_O = 5\text{ to }200\text{ mA}$, $T_J = 25\text{ }^\circ\text{C}$			120	
I_d	Quiescent current				6	mA
ΔI_d	Quiescent current change	$I_O = 5\text{ to }350\text{ mA}$			0.5	mA
		$I_O = 200\text{ mA}$, $V_I = 14.5\text{ to }30\text{ V}$			0.8	
$\Delta V_O/\Delta T$	Output voltage drift	$I_O = 5\text{ mA}$, $T_J = 0\text{ to }125\text{ }^\circ\text{C}$		-1		mV/°C
SVR	Supply voltage rejection	$V_I = 15\text{ to }25\text{ V}$, $f = 120\text{ Hz}$, $I_O = 300\text{ mA}$	55			dB
eN	Output noise voltage	$B = 10\text{ Hz to }100\text{ kHz}$		75		μV
V_d	Dropout voltage			2		V
I_{sc}	Short circuit current	$V_I = 35\text{ V}$		240		mA

Table 9. Electrical characteristics of L78M15C (refer to the test circuits, $T_J = 25\text{ }^\circ\text{C}$, $V_I = 23\text{ V}$, $I_O = 350\text{ mA}$, $C_I = 0.33\text{ }\mu\text{F}$, $C_O = 0.1\text{ }\mu\text{F}$ unless otherwise specified)

Symbol	Parameter	Test conditions	Min.	Typ.	Max.	Unit
V_O	Output voltage		14.4	15	15.6	V
V_O	Output voltage	$I_O = 5\text{ to }350\text{ mA}$, $V_I = 17.5\text{ to }30\text{ V}$	14.25	15	15.75	V
ΔV_O	Line regulation	$V_I = 17.5\text{ to }30\text{ V}$, $I_O = 200\text{ mA}$			100	mV
		$V_I = 20\text{ to }30\text{ V}$, $I_O = 200\text{ mA}$			50	
ΔV_O	Load regulation	$I_O = 5\text{ to }500\text{ mA}$, $T_J = 25\text{ }^\circ\text{C}$			300	mV
		$I_O = 5\text{ to }200\text{ mA}$, $T_J = 25\text{ }^\circ\text{C}$			150	
I_d	Quiescent current				6	mA
ΔI_d	Quiescent current change	$I_O = 5\text{ to }350\text{ mA}$			0.5	mA
		$I_O = 200\text{ mA}$, $V_I = 17.5\text{ to }30\text{ V}$			0.8	
$\Delta V_O/\Delta T$	Output voltage drift	$I_O = 5\text{ mA}$, $T_J = 0\text{ to }125\text{ }^\circ\text{C}$		-1		mV/°C
SVR	Supply voltage rejection	$V_I = 18.5\text{ to }28.5\text{ V}$, $f = 120\text{ Hz}$, $I_O = 300\text{ mA}$	54			dB
eN	Output noise voltage	$B = 10\text{ Hz to }100\text{ kHz}$		90		μV
V_d	Dropout voltage			2		V
I_{sc}	Short circuit current	$V_I = 35\text{ V}$		240		mA

TO-220 mechanical data

Dim.	mm.			inch.		
	Min.	Typ.	Max.	Min.	Typ.	Max.
A	4.40		4.60	0.173		0.181
C	1.23		1.32	0.048		0.051
D	2.40		2.72	0.094		0.107
D1		1.27			0.050	
E	0.49		0.70	0.019		0.027
F	0.61		0.88	0.024		0.034
F1	1.14		1.70	0.044		0.067
F2	1.14		1.70	0.044		0.067
G	4.95		5.15	0.194		0.203
G1	2.4		2.7	0.094		0.106
H2	10.0		10.40	0.393		0.409
L2		16.4			0.645	
L4	13.0		14.0	0.511		0.551
L5	2.65		2.95	0.104		0.116
L6	15.25		15.75	0.600		0.620
L7	6.2		6.6	0.244		0.260
L9	3.5		3.93	0.137		0.154
DIA.	3.75		3.85	0.147		0.151

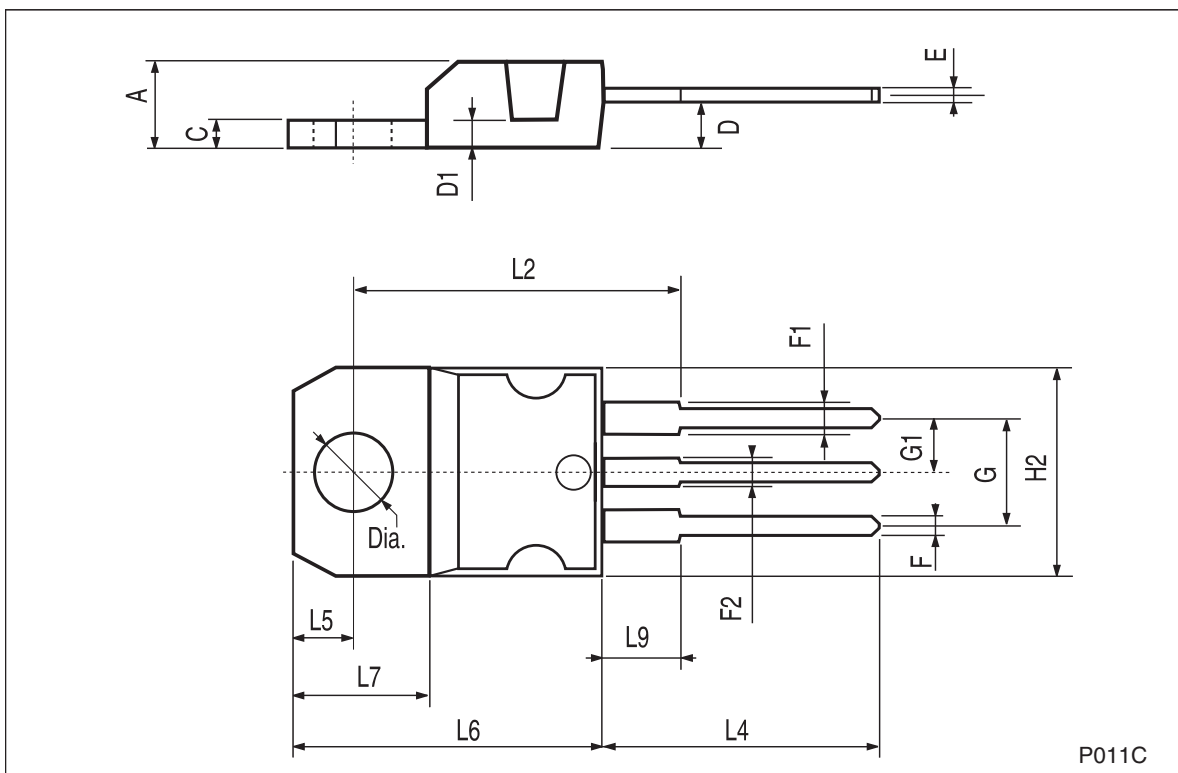

P011C

8 Order codes

Table 13. Order codes

Packages				
TO-220	TO-220FP	DPAK	IPAK	Output voltage
L78M05CV	L78M05CP	L78M05CDT-TR	L78M05CDT-1	5 V
		L78M06CDT-TR	L78M06CDT-1 ⁽¹⁾	6 V
L78M08CV		L78M08CDT-TR	L78M08CDT-1 ⁽¹⁾	8 V
L78M09CV		L78M09CDT-TR	L78M09CDT-1 ⁽¹⁾	9 V
L78M12CV		L78M12CDT-TR		12 V
L78M15CV		L78M15CDT-TR		15 V
L78M24CV	L78M24CP ⁽¹⁾	L78M24CDT-TR	L78M24CDT-1 ⁽¹⁾	24 V

1. Available on request