



M24C16, M24C08 M24C04, M24C02, M24C01

16 Kbit, 8 Kbit, 4 Kbit, 2 Kbit and 1 Kbit serial I²C bus EEPROM

Features

- Two-wire I²C serial interface
 - Supports 400 kHz protocol
- Single supply voltage:
 - 2.5 V to 5.5 V for M24Cxx-W
 - 1.8 V to 5.5 V for M24Cxx-R
 - 1.7 V to 5.5 V for M24Cxx-F
- Write Control input
- Byte and Page Write (up to 16 bytes)
- Random and Sequential Read modes
- Self-timed programming cycle
- Automatic address incrementing
- Enhanced ESD/latch-up protection
- More than 1 million write cycles
- More than 40-year data retention
- Packages
 - ECOPACK[®] (RoHS compliant)

Table 1. Device summary

Reference	Part number
M24C16	M24C16-W
	M24C16-R
	M24C16-F
M24C08	M24C08-W
	M24C08-R
	M24C08-F
M24C04	M24C04-W
	M24C04-R
	M24C04-F
M24C02	M24C02-W
	M24C02-R
M24C01	M24C01-W
	M24C01-R

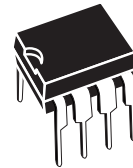

PDIP8 (BN)



SO8 (MN)
150 mils width



TSSOP8 (DW)
169 mils width



TSSOP8 (DS)
3 × 3 mm body size



UFDFPN8 (MB)
2 × 3 mm (MLP)



WLCSP (CS)⁽¹⁾

1. Only M24C08-R and M24C08-F devices are offered in the WLCSP package.

1 Description

These I²C-compatible electrically erasable programmable memory (EEPROM) devices are organized as 2048/1024/512/256/128 x 8 (M24C16, M24C08, M24C04, M24C02 and M24C01).

Figure 1. Logic diagram

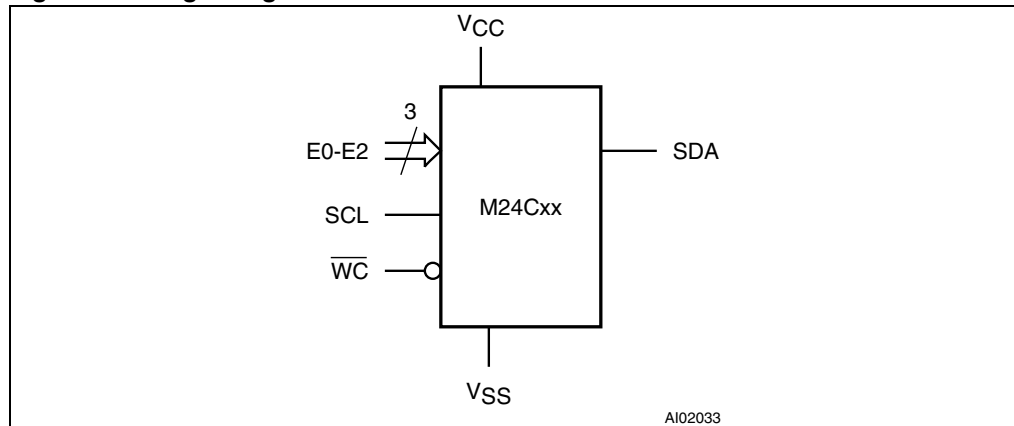

I²C uses a two-wire serial interface, comprising a bidirectional data line and a clock line. The devices carry a built-in 4-bit Device Type Identifier code (1010) in accordance with the I²C bus definition.

The device behaves as a slave in the I²C protocol, with all memory operations synchronized by the serial clock. Read and Write operations are initiated by a Start condition, generated by the bus master. The Start condition is followed by a device select code and Read/Write bit (\overline{RW}) (as described in [Table 3](#)), terminated by an acknowledge bit.

When writing data to the memory, the device inserts an acknowledge bit during the 9th bit time, following the bus master's 8-bit transmission. When data is read by the bus master, the bus master acknowledges the receipt of the data byte in the same way. Data transfers are terminated by a Stop condition after an Ack for Write, and after a NoAck for Read.

Table 2. Signal names

Signal name	Function	Direction
E0, E1, E2	Chip Enable	Input
SDA	Serial Data	Input/output
SCL	Serial Clock	Input
\overline{WC}	Write Control	Input
V _{CC}	Supply voltage	
V _{SS}	Ground	

4 Initial delivery state

The device is delivered with all bits in the memory array set to 1 (each byte contains FFh).

5 Maximum rating

Stressing the device outside the ratings listed in [Table 5](#) may cause permanent damage to the device. These are stress ratings only, and operation of the device at these, or any other conditions outside those indicated in the operating sections of this specification, is not implied. Exposure to absolute maximum rating conditions for extended periods may affect device reliability. Refer also to the STMicroelectronics SURE program and other relevant quality documents.

Table 5. Absolute maximum ratings

Symbol	Parameter	Min.	Max.	Unit
T_A	Ambient operating temperature	-40	130	°C
T_{STG}	Storage temperature	-65	150	°C
T_{LEAD}	Lead temperature during soldering	see note ⁽¹⁾		°C
	PDIP-specific lead temperature during soldering		260 ⁽²⁾	°C
I_{OL}	DC output current (SDA = 0)	-	5	mA
V_{IO}	Input or output range	-0.50	6.5	V
V_{CC}	Supply voltage	-0.50	6.5	V
V_{ESD}	Electrostatic discharge voltage (human body model) ⁽³⁾	-4000	4000	V

1. Compliant with JEDEC Std J-STD-020C (for small body, Sn-Pb or Pb assembly), the ST ECOPACK[®] 7191395 specification, and the European directive on Restrictions on Hazardous Substances (RoHS) 2002/95/EU.
2. T_{LEAD} max must not be applied for more than 10 s.
3. AEC-Q100-002 (compliant with JEDEC Std JESD22-A114, C1 = 100 pF, R1 = 1500 Ω , R2 = 500 Ω).

6 DC and AC parameters

This section summarizes the operating and measurement conditions, and the DC and AC characteristics of the device. The parameters in the DC and AC characteristic tables that follow are derived from tests performed under the measurement conditions summarized in the relevant tables. Designers should check that the operating conditions in their circuit match the measurement conditions when relying on the quoted parameters.

Table 6. Operating conditions (M24Cxx-W)

Symbol	Parameter	Min.	Max.	Unit
V_{CC}	Supply voltage	2.5	5.5	V
T_A	Ambient operating temperature (device grade 6)	-40	85	°C
	Ambient operating temperature (device grade 3)	-40	125	°C

Table 7. Operating conditions (M24Cxx-R)

Symbol	Parameter	Min.	Max.	Unit
V_{CC}	Supply voltage	1.8	5.5	V
T_A	Ambient operating temperature	-40	85	°C

Table 8. Operating conditions (M24Cxx-F)

Symbol	Parameter	Min.	Max.	Unit
V_{CC}	Supply voltage	1.7	5.5	V
T_A	Ambient operating temperature	-20	85	°C

Table 9. DC characteristics (M24Cxx-W, device grade 6)

Symbol	Parameter	Test conditions (in addition to those in Table 6)	Min.	Max.	Unit
I_{LI}	Input leakage current (SCL, SDA, E0, E1, and E2)	$V_{IN} = V_{SS}$ or V_{CC} , device in Standby mode		± 2	µA
I_{LO}	Output leakage current	$V_{OUT} = V_{SS}$ or V_{CC} , SDA in Hi-Z		± 2	µA
I_{CC}	Supply current	$V_{CC} = 5\text{ V}$, $f_c = 400\text{ kHz}$ (rise/fall time < 50 ns)		2	mA
		$V_{CC} = 2.5\text{ V}$, $f_c = 400\text{ kHz}$ (rise/fall time < 50 ns)		1	mA
I_{CC1}	Standby supply current	Device not selected ⁽¹⁾ , $V_{IN} = V_{SS}$ or V_{CC} , for $2.5\text{ V} < V_{CC} \leq 5.5\text{ V}$		1	µA
V_{IL}	Input low voltage (SDA, SCL, \overline{WC})		-0.45	$0.3V_{CC}$	V
V_{IH}	Input high voltage (SDA, SCL, \overline{WC})		$0.7V_{CC}$	$V_{CC}+1$	V
V_{OL}	Output low voltage	$I_{OL} = 2.1\text{ mA}$ when $V_{CC} = 2.5\text{ V}$ or $I_{OL} = 3\text{ mA}$ when $V_{CC} = 5.5\text{ V}$		0.4	V

1. The device is not selected after a power-up, after a read command (after the Stop condition), or after the completion of the internal write cycle t_W (t_W is triggered by the correct decoding of a write command).

Table 10. DC characteristics (M24Cxx-W, device grade 3)

Symbol	Parameter	Test condition (in addition to those in Table 6)	Min.	Max.	Unit
I_{LI}	Input leakage current (SCL, SDA, E0, E1, and E2)	$V_{IN} = V_{SS}$ or V_{CC} , device in Standby mode		± 2	μA
I_{LO}	Output leakage current	$V_{OUT} = V_{SS}$ or V_{CC} , SDA in Hi-Z		± 2	μA
I_{CC}	Supply current	$V_{CC} = 5 V$, $f_C = 400 kHz$ (rise/fall time < 50 ns)		3	mA
		$V_{CC} = 2.5 V$, $f_C = 400 kHz$ (rise/fall time < 50 ns)		3	mA
I_{CC1}	Standby supply current	Device not selected ⁽¹⁾ , $V_{IN} = V_{SS}$ or V_{CC} , $V_{CC} = 5 V$		5	μA
		Device not selected ⁽¹⁾ , $V_{IN} = V_{SS}$ or V_{CC} , $V_{CC} = 2.5 V$		2	μA
V_{IL}	Input low voltage (SDA, SCL, \overline{WC})		-0.45	$0.3V_{CC}$	V
V_{IH}	Input high voltage (SDA, SCL, \overline{WC})		$0.7V_{CC}$	$V_{CC}+1$	V
V_{OL}	Output low voltage	$I_{OL} = 2.1 mA$ when $V_{CC} = 2.5 V$ or $I_{OL} = 3 mA$ when $V_{CC} = 5.5 V$		0.4	V

1. The device is not selected after a power-up, after a read command (after the Stop condition), or after the completion of the internal write cycle t_W (t_W is triggered by the correct decoding of a write command).

Table 11. DC characteristics (M24Cxx-R)

Symbol	Parameter	Test condition (in addition to those in Table 7)	Min.	Max.	Unit
I_{LI}	Input leakage current (SCL, SDA, E0, E1, and E2)	$V_{IN} = V_{SS}$ or V_{CC} , device in Standby mode		± 2	μA
I_{LO}	Output leakage current	$V_{OUT} = V_{SS}$ or V_{CC} , SDA in Hi-Z		± 2	μA
I_{CC}	Supply current	$V_{CC} = 1.8 V$, $f_C = 400 kHz$ (rise/fall time < 50 ns)		0.8	mA
I_{CC1}	Standby supply current	Device not selected ⁽¹⁾ , $V_{IN} = V_{SS}$ or V_{CC} , $V_{CC} = 1.8 V$		1	μA
V_{IL}	Input low voltage (SDA, SCL, \overline{WC})	$2.5 V \leq V_{CC}$	-0.45	$0.3 V_{CC}$	V
		$1.8 V \leq V_{CC} < 2.5 V$	-0.45	$0.25 V_{CC}$	V
V_{IH}	Input high voltage (SDA, SCL, \overline{WC})		$0.7V_{CC}$	$V_{CC}+1$	V
V_{OL}	Output low voltage	$I_{OL} = 0.7 mA$, $V_{CC} = 1.8 V$		0.2	V

1. The device is not selected after a power-up, after a read command (after the Stop condition), or after the completion of the internal write cycle t_W (t_W is triggered by the correct decoding of a write command).

Table 12. DC characteristics (M24Cxx-F)

Symbol	Parameter	Test condition (in addition to those in Table 7)	Min.	Max.	Unit
I_{LI}	Input leakage current (SCL, SDA, E0, E1, and E2)	$V_{IN} = V_{SS}$ or V_{CC} , device in Standby mode		± 2	μA
I_{LO}	Output leakage current	$V_{OUT} = V_{SS}$ or V_{CC} , SDA in Hi-Z		± 2	μA
I_{CC}	Supply current	$V_{CC} = 1.7 V$, $f_c = 400 kHz$ (rise/fall time < 50 ns)		0.8	mA
I_{CC1}	Standby supply current	Device not selected ⁽¹⁾ , $V_{IN} = V_{SS}$ or V_{CC} , $V_{CC} = 1.7 V$		1	μA
V_{IL}	Input low voltage (SDA, SCL, \overline{WC})	$2.5 V \leq V_{CC}$	-0.45	$0.3 V_{CC}$	V
		$1.7 V \leq V_{CC} < 2.5 V$	-0.45	$0.25 V_{CC}$	V
V_{IH}	Input high voltage (SDA, SCL, \overline{WC})		$0.7V_{CC}$	$V_{CC}+1$	V
V_{OL}	Output low voltage	$I_{OL} = 0.7 mA$, $V_{CC} = 1.7 V$		0.2	V

1. The device is not selected after a power-up, after a read command (after the Stop condition), or after the completion of the internal write cycle t_W (t_W is triggered by the correct decoding of a write command).

Table 13. AC measurement conditions

Symbol	Parameter	Min.	Max.	Unit
C_L	Load capacitance	100		pF
	Input rise and fall times		50	ns
	Input levels	$0.2V_{CC}$ to $0.8V_{CC}$		V
	Input and output timing reference levels	$0.3V_{CC}$ to $0.7V_{CC}$		V

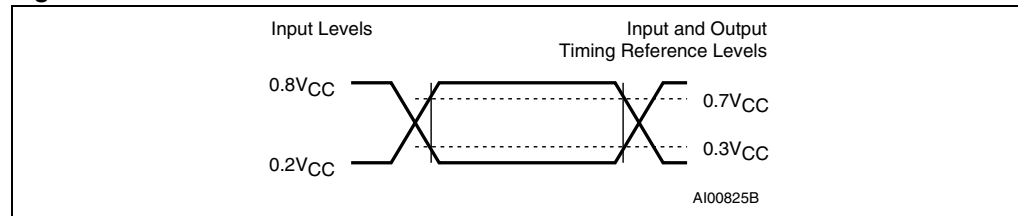
Figure 11. AC measurement I/O waveform**Table 14. Input parameters**

Symbol	Parameter ⁽¹⁾	Test condition	Min.	Max.	Unit
C_{IN}	Input capacitance (SDA)			8	pF
C_{IN}	Input capacitance (other pins)			6	pF
Z_{WCL}	\overline{WC} input impedance	$V_{IN} < 0.3 V$	15	70	$k\Omega$
Z_{WCH}	\overline{WC} input impedance	$V_{IN} > 0.7V_{CC}$	500		$k\Omega$
t_{NS}	Pulse width ignored (input filter on SCL and SDA)	Single glitch		100	ns

1. Characterized only.

Table 15. AC characteristics (M24Cxx-W, M24Cxx-R, M24Cxx-F)

Test conditions specified in Table 6 and Table 13					
Symbol	Alt.	Parameter	Min.	Max.	Unit
f_C	f_{SCL}	Clock frequency		400	kHz
t_{CHCL}	t_{HIGH}	Clock pulse width high	600		ns
t_{CLCH}	t_{LOW}	Clock pulse width low	1300		ns
$t_{XH1XH2}^{(1)}$	t_R	Input signal rise time	20	300	ns
$t_{XL1XL2}^{(1)}$	t_F	Input signal fall time	20	300	ns
$t_{DL1DL2}^{(2)}$	t_F	SDA fall time	20	300	ns
t_{DXCX}	$t_{SU:DAT}$	Data in setup time	100		ns
t_{CLDX}	$t_{HD:DAT}$	Data in hold time	0		ns
t_{CLQX}	t_{DH}	Data out hold time	200		ns
$t_{CLQV}^{(3)}$	t_{AA}	Clock low to next data valid (access time)	200	900	ns
$t_{CHDX}^{(4)}$	$t_{SU:STA}$	Start condition setup time	600		ns
t_{DLCL}	$t_{HD:STA}$	Start condition hold time	600		ns
t_{CHDH}	$t_{SU:STO}$	Stop condition setup time	600		ns
t_{DHDL}	t_{BUF}	Time between Stop condition and next Start condition	1300		ns
t_W	t_{WR}	Write time		5	ms

1. Values recommended by the I²C bus Fast-mode specification.
2. Characterized only.
3. To avoid spurious Start and Stop conditions, a minimum delay is placed between SCL=1 and the falling or rising edge of SDA.
4. For a reStart condition, or following a Write cycle.

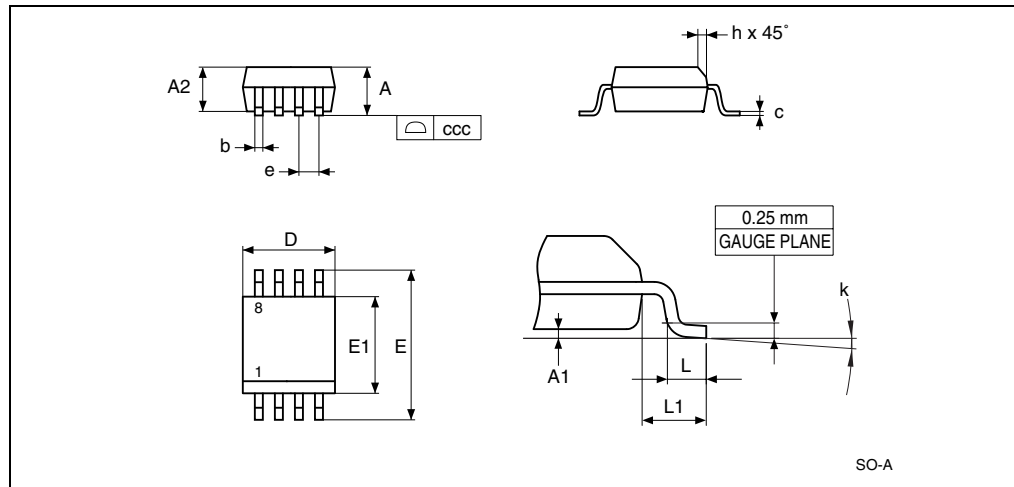
Figure 15. SO8 narrow – 8 lead plastic small outline, 150 mils body width, package outline

1. Drawing is not to scale.
2. The '1' that appears in the top view of the package shows the position of pin 1 and the 'N' indicates the total number of pins.

Table 18. SO8 narrow – 8 lead plastic small outline, 150 mils body width, package mechanical data

Symbol	millimeters			inches ⁽¹⁾		
	Typ	Min	Max	Typ	Min	Max
A			1.75			0.0689
A1		0.1	0.25		0.0039	0.0098
A2		1.25			0.0492	
b		0.28	0.48		0.011	0.0189
c		0.17	0.23		0.0067	0.0091
ccc			0.1			0.0039
D	4.9	4.8	5	0.1929	0.189	0.1969
E	6	5.8	6.2	0.2362	0.2283	0.2441
E1	3.9	3.8	4	0.1535	0.1496	0.1575
e	1.27	-	-	0.05	-	-
h		0.25	0.5		0.0098	0.0197
k		0°	8°		0°	8°
L		0.4	1.27		0.0157	0.05
L1	1.04			0.0409		

1. Values in inches are converted from mm and rounded to 4 decimal digits.

8 Part numbering

Table 22. Ordering information scheme

Example:	M24C16	-	W	DW	3	T	P	/S
Device type	M24 = I ² C serial access EEPROM							
Device Function	16 = 16 Kbit (2048 x 8) 08 = 8 Kbit (1024 x 8) 04 = 4 Kbit (512 x 8) 02 = 2 Kbit (256 x 8) 01 = 1 Kbit (128 x 8)							
Operating voltage	W = V _{CC} = 2.5 V to 5.5 V (400 kHz) R = V _{CC} = 1.8 V to 5.5 V (400 kHz) F = V _{CC} = 1.7 V to 5.5 V (400 kHz)							
Package	BN = PDIP8 MN = SO8 (150 mil width) MB = UFDFPN8 (MLP8) DW = TSSOP8 (169 mil width) DS = TSSOP8 (3 x 3 mm body size, MSOP8) ⁽¹⁾ CS = WLCSP ⁽²⁾							
Device grade	6 = Industrial: device tested with standard test flow over -40 to 85 °C 3 = Automotive: device tested with high reliability certified flow ⁽³⁾ over -40 to 125 °C 5 = Consumer: device tested with standard test flow over -20 to 85 °C.							
Option	T = Tape and reel packing							
Plating technology	P or G = ECOPACK [®] (RoHS compliant)							
Process⁽⁴⁾	/S = F6SP36%							

1. Products sold in this package are not recommended for new design.
2. Only M24C08-R and M24C08-F devices are offered in the WLCSP package.
3. ST strongly recommends the use of the Automotive Grade devices for use in an automotive environment. The High Reliability Certified Flow (HRCF) is described in the quality note QNEE9801. Please ask your nearest ST sales office for a copy.
4. Used only for device grade 3.

For a list of available options (speed, package, etc.) or for further information on any aspect of this device, please contact your nearest ST sales office.