

MC14024B

7-Stage Ripple Counter

The MC14024B is a 7-stage ripple counter with short propagation delays and high maximum clock rates. The Reset input has standard noise immunity, however the Clock input has increased noise immunity due to Hysteresis. The output of each counter stage is buffered.

Features

- Diode Protection on All Inputs
- Output Transitions Occur on the Falling Edge of the Clock Pulse
- Supply Voltage Range = 3.0 Vdc to 18 Vdc
- Capable of Driving Two Low-power TTL Loads or One Low-power Schottky TTL Load Over the Rated Temperature Range
- Pin-for-Pin Replacement for CD4024B
- Pb-Free Packages are Available

MAXIMUM RATINGS (Voltages Referenced to V_{SS})

| Symbol | Parameter | Value | Unit |
|-------------------|---|------------------------|-------------|
| V_{DD} | DC Supply Voltage Range | -0.5 to +18.0 | V |
| V_{in}, V_{out} | Input or Output Voltage Range (DC or Transient) | -0.5 to $V_{DD} + 0.5$ | V |
| I_{in}, I_{out} | Input or Output Current (DC or Transient) per Pin | ± 10 | mA |
| P_D | Power Dissipation, per Package (Note 1) | 500 | mW |
| T_A | Ambient Temperature Range | -55 to +125 | $^{\circ}C$ |
| T_{stg} | Storage Temperature Range | -65 to +150 | $^{\circ}C$ |
| T_L | Lead Temperature (8-Second Soldering) | 260 | $^{\circ}C$ |

Stresses exceeding Maximum Ratings may damage the device. Maximum Ratings are stress ratings only. Functional operation above the Recommended Operating Conditions is not implied. Extended exposure to stresses above the Recommended Operating Conditions may affect device reliability.

1. Temperature Derating:

Plastic "P and D/DW" Packages: - 7.0 mW/ $^{\circ}C$ From 65 $^{\circ}C$ To 125 $^{\circ}C$

This device contains protection circuitry to guard against damage due to high static voltages or electric fields. However, precautions must be taken to avoid applications of any voltage higher than maximum rated voltages to this high-impedance circuit. For proper operation, V_{in} and V_{out} should be constrained to the range $V_{SS} \leq (V_{in} \text{ or } V_{out}) \leq V_{DD}$.

Unused inputs must always be tied to an appropriate logic voltage level (e.g., either V_{SS} or V_{DD}). Unused outputs must be left open.



ON Semiconductor®

MARKING DIAGRAMS

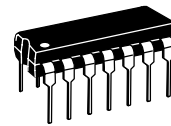

PDIP-14
P SUFFIX
CASE 646

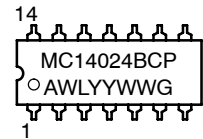

SOIC-14
D SUFFIX
CASE 751A

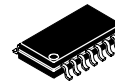
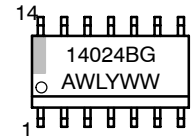

SOEIAJ-14
F SUFFIX
CASE 965

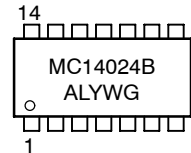

A = Assembly Location
WL, L = Wafer Lot
YY, Y = Year
WW, W = Work Week
G = Pb-Free Package

ORDERING INFORMATION

See detailed ordering and shipping information in the package dimensions section on page 2 of this data sheet.

MC14024B

TRUTH TABLE

| Clock | Reset | State |
|-------|-------|-------------------|
| 0 | 0 | No Change |
| 0 | 1 | All Outputs Low |
| 1 | 0 | No Change |
| 1 | 1 | All Outputs Low |
| ↗ | 0 | No Change |
| ↗ | 1 | All Outputs Low |
| ↘ | 0 | Advance One Count |
| ↘ | 1 | All Outputs Low |

PIN ASSIGNMENT

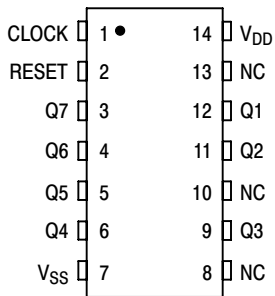

V_{DD} = PIN 14
 V_{SS} = PIN 7
 NC = NO CONNECTION

LOGIC DIAGRAM

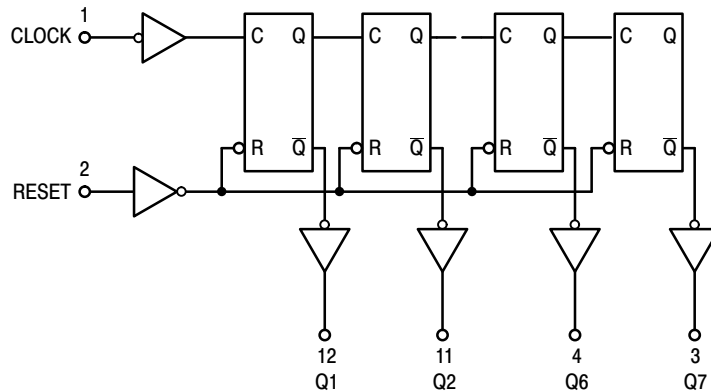

Q3 = PIN 9
 Q4 = PIN 6
 Q5 = PIN 5

ORDERING INFORMATION

| Device | Package | Shipping [†] |
|--------------|------------------------|-----------------------|
| MC14024BCP | PDIP-14 | 25 Units / Rail |
| MC14024BCPG | PDIP-14 (Pb-Free) | |
| MC14024BD | SOIC-14 | 55 Units / Rail |
| MC14024BDG | SOIC-14 (Pb-Free) | |
| MC14024BDR2 | SOIC-14 | 2500 / Tape & Reel |
| MC14024BDR2G | SOIC-14 (Pb-Free) | |
| MC14024BFEL | SOEIAJ-14 | 2000 / Tape & Reel |
| MC14024BFELG | SOEIAJ-14 (Pb-Free) | |

[†]For information on tape and reel specifications, including part orientation and tape sizes, please refer to our Tape and Reel Packaging Specifications Brochure, BRD8011/D.

MC14024B

ELECTRICAL CHARACTERISTICS (Voltages Referenced to V_{SS})

| Characteristic | Symbol | V _{DD} Vdc | - 55°C | | 25°C | | | 125°C | | Unit |
|---|------------------------------|------------------------|---|-------|-------|-----------------|-------|-------|-------|------|
| | | | Min | Max | Min | Typ (Note 2) | Max | Min | Max | |
| Output Voltage V _{in} = V _{DD} or 0 | “0” Level V _{OL} | 5.0 | – | 0.05 | – | 0 | 0.05 | – | 0.05 | Vdc |
| | | 10 | – | 0.05 | – | 0 | 0.05 | – | 0.05 | |
| 15 | | – | 0.05 | – | 0 | 0.05 | – | 0.05 | | |
| V _{in} = 0 or V _{DD} | “1” Level V _{OH} | 5.0 | 4.95 | – | 4.95 | 5.0 | – | 4.95 | – | Vdc |
| | | 10 | 9.95 | – | 9.95 | 10 | – | 9.95 | – | |
| | | 15 | 14.95 | – | 14.95 | 15 | – | 14.95 | – | |
| Input Voltage (V _O = 4.5 or 0.5 Vdc) (V _O = 9.0 or 1.0 Vdc) (V _O = 13.5 or 1.5 Vdc) | “0” Level V _{IL} | 5.0 | – | 1.5 | – | 2.25 | 1.5 | – | 1.5 | Vdc |
| | | 10 | – | 3.0 | – | 4.50 | 3.0 | – | 3.0 | |
| 15 | | – | 4.0 | – | 6.75 | 4.0 | – | 4.0 | | |
| (V _O = 0.5 or 4.5 Vdc) (V _O = 1.0 or 9.0 Vdc) (V _O = 1.5 or 13.5 Vdc) | “1” Level V _{IH} | 5.0 | 3.5 | – | 3.5 | 2.75 | – | 3.5 | – | Vdc |
| | | 10 | 7.0 | – | 7.0 | 5.50 | – | 7.0 | – | |
| | | 15 | 11 | – | 11 | 8.25 | – | 11 | – | |
| Output Drive Current (V _{OH} = 2.5 Vdc) (V _{OH} = 4.6 Vdc) (V _{OH} = 9.5 Vdc) (V _{OH} = 13.5 Vdc) | Source I _{OH} | 5.0 | –3.0 | – | –2.4 | –4.2 | – | –1.7 | – | mAdc |
| | | 5.0 | –0.64 | – | –0.51 | –0.88 | – | –0.36 | – | |
| 10 | | –1.6 | – | –1.3 | –2.25 | – | –0.9 | – | | |
| 15 | | –4.2 | – | –3.4 | –8.8 | – | –2.4 | – | | |
| (V _{OL} = 0.4 Vdc) (V _{OL} = 0.5 Vdc) (V _{OL} = 1.5 Vdc) | Sink I _{OL} | 5.0 | 0.64 | – | 0.51 | 0.88 | – | 0.36 | – | mAdc |
| | | 10 | 1.6 | – | 1.3 | 2.25 | – | 0.9 | – | |
| | | 15 | 4.2 | – | 3.4 | 8.8 | – | 2.4 | – | |
| Input Current | I _{in} | 15 | – | ± 0.1 | – | ± 0.00001 | ± 0.1 | – | ± 1.0 | μAdc |
| Input Capacitance (V _{in} = 0) | C _{in} | – | – | – | – | 5.0 | 7.5 | – | – | pF |
| Quiescent Current (Per Package) | I _{DD} | 5.0 | – | 5.0 | – | 0.005 | 5.0 | – | 150 | μAdc |
| | | 10 | – | 10 | – | 0.010 | 10 | – | 300 | |
| | | 15 | – | 20 | – | 0.015 | 20 | – | 600 | |
| Total Supply Current (Notes 3 & 4) (Dynamic plus Quiescent, Per Package) (C _L = 50 pF on all outputs, all buffers switching) | I _T | 5.0 10 15 | $I_T = (0.31 \mu\text{A/kHz}) f + I_{DD}$ $I_T = (0.60 \mu\text{A/kHz}) f + I_{DD}$ $I_T = (1.89 \mu\text{A/kHz}) f + I_{DD}$ | | | | | | | μAdc |

2. Data labelled “Typ” is not to be used for design purposes but is intended as an indication of the IC’s potential performance.

3. The formulas given are for the typical characteristics only at 25°C.

4. To calculate total supply current at loads other than 50 pF:

$$I_T(C_L) = I_T(50 \text{ pF}) + (C_L - 50) \text{ Vfk}$$

where: I_T is in μA (per package), C_L in pF, V = (V_{DD} – V_{SS}) in volts, f in kHz is input frequency, and k = 0.001.

MC14024B

SWITCHING CHARACTERISTICS (Note 5) ($C_L = 50 \text{ pF}$, $T_A = 25^\circ\text{C}$)

| Characteristic | Symbol | V_{DD} | Min | Typ (Note 6) | Max | Unit |
|---|-------------------------|---|---|--|--|--------------------------|
| Output Rise and Fall Time $t_{TLH}, t_{THL} = (1.5 \text{ ns/pF}) C_L + 25 \text{ ns}$ $t_{TLH}, t_{THL} = (0.75 \text{ ns/pF}) C_L + 12.5 \text{ ns}$ $t_{TLH}, t_{THL} = (0.55 \text{ ns/pF}) C_L + 9.5 \text{ ns}$ | $t_{TLH},$ t_{THL} | 5.0 10 15 | – – – | 100 50 40 | 200 100 80 | ns |
| Propagation Delay Time Clock to Q1 $t_{PLH}, t_{PHL} = (1.7 \text{ ns/pF}) C_L + 295 \text{ ns}$ $t_{PLH}, t_{PHL} = (0.66 \text{ ns/pF}) C_L + 117 \text{ ns}$ $t_{PLH}, t_{PHL} = (0.5 \text{ ns/pF}) C_L + 85 \text{ ns}$ Clock to Q7 $t_{PLH}, t_{PHL} = (1.7 \text{ ns/pF}) C_L + 915 \text{ ns}$ $t_{PLH}, t_{PHL} = (0.66 \text{ ns/pF}) C_L + 367 \text{ ns}$ $t_{PLH}, t_{PHL} = (0.5 \text{ ns/pF}) C_L + 275 \text{ ns}$ Reset to Q_n $t_{PLH}, t_{PHL} = (1.7 \text{ ns/pF}) C_L + 415 \text{ ns}$ $t_{PLH}, t_{PHL} = (0.66 \text{ ns/pF}) C_L + 217 \text{ ns}$ $t_{PLH}, t_{PHL} = (0.5 \text{ ns/pF}) C_L + 155 \text{ ns}$ | $t_{PLH},$ t_{PHL} | 5.0 10 15 5.0 10 15 5.0 10 15 | – – – – – – – – – | 380 150 110 1000 400 300 500 250 180 | 600 230 175 2000 750 565 800 400 300 | ns |
| Clock Pulse Width | t_{WH} | 5.0 10 15 | 500 165 125 | 200 60 40 | – – – | ns |
| Reset Pulse Width | t_{WH} | 5.0 10 15 | 600 350 260 | 375 200 150 | – – – | ns |
| Reset Removal Time | t_{rem} | 5.0 10 15 | 625 190 145 | 250 75 50 | – – – | ns |
| Clock Input Rise and Fall Time | t_{TLH}, t_{THL} | 5.0 10 15 | – – – | – – – | 1.0 8.0 200 | s ms μs |
| Input Pulse Frequency | f_{cl} | 5.0 10 15 | – – – | 2.5 8.0 12 | 1.0 3.0 4.0 | MHz |

5. The formulas given are for the typical characteristics only at 25°C .

6. Data labelled "Typ" is not to be used for design purposes but is intended as an indication of the IC's potential performance.

MC14024B

PACKAGE DIMENSIONS

PDIP-14
CASE 646-06
ISSUE P

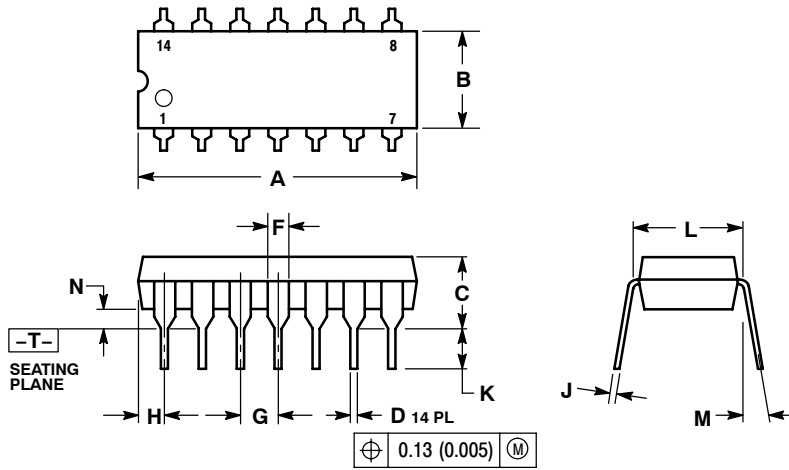

NOTES:

1. DIMENSIONING AND TOLERANCING PER ANSI Y14.5M, 1982.
2. CONTROLLING DIMENSION: INCH.
3. DIMENSION L TO CENTER OF LEADS WHEN FORMED PARALLEL.
4. DIMENSION B DOES NOT INCLUDE MOLD FLASH.
5. ROUNDED CORNERS OPTIONAL.

| DIM | INCHES | | MILLIMETERS | |
|-----|-----------|-------|-------------|-------|
| | MIN | MAX | MIN | MAX |
| A | 0.715 | 0.770 | 18.16 | 19.56 |
| B | 0.240 | 0.260 | 6.10 | 6.60 |
| C | 0.145 | 0.185 | 3.69 | 4.69 |
| D | 0.015 | 0.021 | 0.38 | 0.53 |
| F | 0.040 | 0.070 | 1.02 | 1.78 |
| G | 0.100 BSC | | 2.54 BSC | |
| H | 0.052 | 0.095 | 1.32 | 2.41 |
| J | 0.008 | 0.015 | 0.20 | 0.38 |
| K | 0.115 | 0.135 | 2.92 | 3.43 |
| L | 0.290 | 0.310 | 7.37 | 7.87 |
| M | --- | 10° | --- | 10° |
| N | 0.015 | 0.039 | 0.38 | 1.01 |