

## Transient Voltage ESD Suppressor TVSA Series



### Description

Cooper Bussmann® TVSA Series of transient voltage suppressors are designed to protect electronic circuits from ESD damage. With its small, standardized 0201 and 0402 sizes, it's easy to implement them into any circuit board design.

### Features

- Silicon based chip
- Low capacitance to meet the needs for high speed single transient voltage protection
- Provides ESD protection with fast response time (<1ns) allowing equipment to pass IEC 61000-4-2 level 4 test
- Low profile designs for board space savings
- Low leakage current reduces power consumption
- Low clamping voltage
- Solid-state silicon-avalanche technology
- Lead free, halogen free and RoHS compliant for global applications

### Applications

- Computers and peripherals
- Digital still cameras
- Cell phones
- PDAs
- DVD Players
- MP3/Multimedia players
- A-V Equipment
- External storage
- DSL Modems
- Set top boxes
- Docking systems

### Part Numbering System: TVSA 04 V05 C006



### Packaging

- Size 0201: 15,000 pieces per reel - EIA (EIAJ)
- Size 0402: 10,000 pieces per reel - EIA (EIAJ)

### Specifications

Part Number	Size	Stand-Off Voltage	Breakdown Voltage	Clamping Voltage At I <sub>peak</sub> = 1A	Capacitance pF	ESD Air/Contact (kV)	Leakage Current (typical)
TVSA02V05C004	0201	5	10	17	4	15/8	< 10nA
TVSA04V05C006	0402	5	10	17	6	15/8	< 10nA

Stand-off Voltage - Maximum DC operating voltage the diode can maintain and not exceed 1µA leakage current.

Breakdown Voltage - Measured at any I/O pin to ground at 1mA DC current.

Clamping Voltage - Maximum peak voltage across the diode with 8/20µs waveform and 1A pulse current.

Capacitance - Device capacitance measured with zero volt bias at 1MHz.

ESD Air/Contact - Voltages tested to IEC 61000-4-2.

### Environmental Specifications

Characteristic	Value
Bias Humidity:	+40°C, 90% RH for 1000 hours
Thermal Shock:	-40°C to +85°C, 30 minute cycle, 5 cycles
Operating Temperature Range:	-40°C to +85°C
Storage Temperature Range:	-40°C to +85°C

### Soldering Recommendations

- Compatible with lead and lead-free solder reflow processes
- Peak reflow temperatures and durations:
  - IR Reflow = 260°C max for 30 sec. max.
  - Wave Solder = 260°C max. for 10 sec. max.
- Recommended IR Reflow Profile:

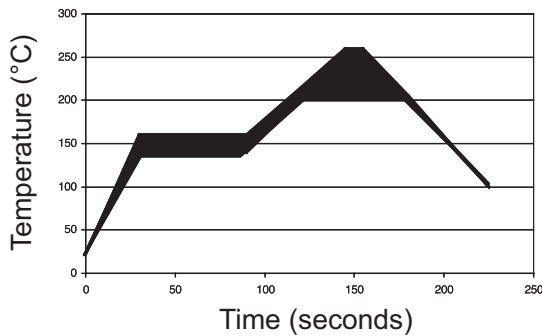

### Recommended Pad Layout - mm (in)

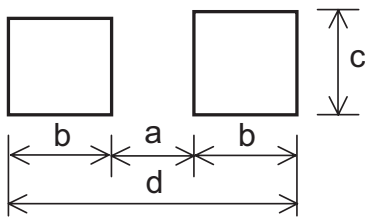

Size	a	b	c	d
0201	0.23 (0.009)	0.30 (0.012)	0.45 (0.018)	0.83 (0.033)
0402	0.51 (0.020)	0.61 (0.024)	0.51 (0.020)	1.70 (0.067)

### Dimensions - mm

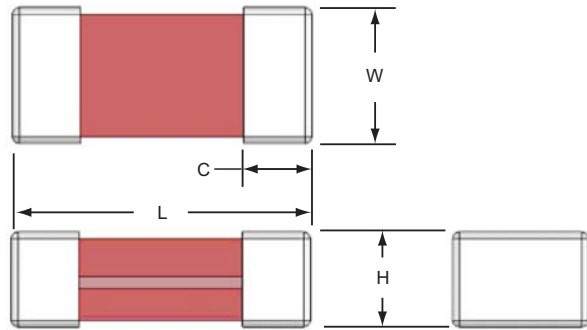

Size	L	W	H	C
0201	0.60±0.05	0.30±0.05	0.30±0.05	0.20±0.10
0402	1.00±0.15	0.50±0.10	0.50±0.10	0.25±0.15

### Tape Packaging Specifications - mm

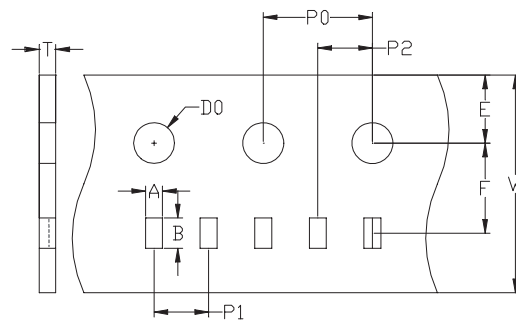

0201 Carrier Dimensions									
A	B	W	E	F	P0	P1	P2	D0	T
0.37 ±0.03	0.69 ±0.03	8.0 ±0.1	1.75 ±0.05	3.5 ±0.05	4.0 ±0.1	2.0 ±0.05	2.0 ±0.05	1.55 ±0.05	0.42 ±0.03
0402 Carrier Dimensions									
0.58 ±0.03	1.2 ±0.03	8.0 ±0.1	1.75 ±0.05	3.5 ±0.05	4.0 ±0.1	2.0 ±0.05	2.0 ±0.05	1.55 ±0.05	0.60 ±0.03

The only controlled copy of this Data Sheet is the electronic read-only version located on the Cooper Bussmann Network Drive. All other copies of this document are by definition uncontrolled. This bulletin is intended to clearly present comprehensive product data and provide technical information that will help the end user with design applications. Cooper Bussmann reserves the right, without notice, to change design or construction of any products and to discontinue or limit distribution of any products. Cooper Bussmann also reserves the right to change or update, without notice, any technical information contained in this bulletin. Once a product has been selected, it should be tested by the user in all possible applications.

Life Support Policy: Cooper Bussmann does not authorize the use of any of its products for use in life support devices or systems without the express written approval of an officer of the Company. Life support systems are devices which support or sustain life, and whose failure to perform, when properly used in accordance with instructions for use provided in the labeling, can be reasonably expected to result in significant injury to the user.