



HCF4049UB

HEX BUFFER/CONVERTER (INVERTING)

- PROPAGATION DELAY TIME:
 $t_{PD} = 40\text{ns}$ (TYP.) at $V_{DD} = 10\text{V}$ $C_L = 50\text{pF}$
- HIGH TO LOW LEVEL LOGIC CONVERSION
- HIGH "SINK" AND "SOURCE" CURRENT CAPABILITY
- QUIESCENT CURRENT SPECIFIED UP TO 20V
- 5V, 10V AND 15V PARAMETRIC RATINGS
- INPUT LEAKAGE CURRENT
 $I_l = 100\text{nA}$ (MAX) AT $V_{DD} = 18\text{V}$ $T_A = 25^\circ\text{C}$
- 100% TESTED FOR QUIESCENT CURRENT

DESCRIPTION

The HCF4049UB is a monolithic integrated circuit fabricated in Metal Oxide Semiconductor technology available in DIP and SOP packages.

It is an inverting Hex Buffer/Converter and feature logic level conversions using only one supply voltage (V_{DD}).

The input high level signal (V_{IH}) can exceed the V_{DD} supply voltage when these devices are used

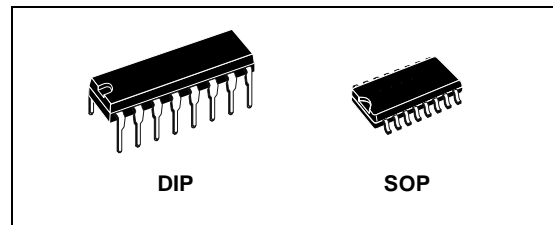

ORDER CODES

PACKAGE	TUBE	T & R
DIP	HCF4049UBEY	
SOP	HCF4049UBM1	HCF4049UM013TR

for logic level conversions. This device is intended for use as CMOS to DTL/TTL converters and can drive directly two DTL/TTL loads ($V_{DD} = 5\text{V}$, $V_{OL} \leq 0.4\text{V}$ and $I_{OL} \leq 3.2\text{mA}$).

PIN CONNECTION

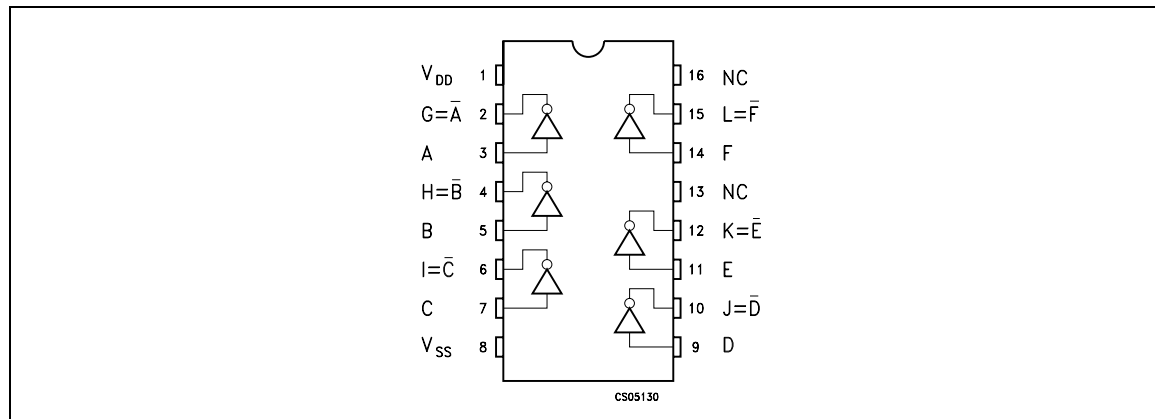

INPUT EQUIVALENT CIRCUIT

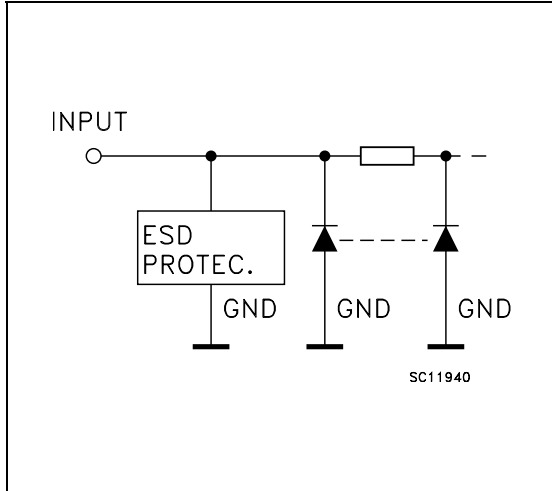

PIN DESCRIPTION

PIN N°	SYMBOL	NAME AND FUNCTION
3, 5, 7, 9, 11, 14	A, B, C, D, E, F	Data Inputs
2, 4, 6, 10, 12, 15	G, H, I, J, K, L	Data Outputs
13, 16	NC	Not Connected
8	V _{SS}	Negative Supply Voltage
1	V _{DD}	Positive Supply Voltage

TRUTH TABLE

INPUTS	OUTPUTS
A, B, C, D, E, F	G, H, I, J, K, L
L	H
H	L

ABSOLUTE MAXIMUM RATINGS

Symbol	Parameter	Value	Unit
V _{DD}	Supply Voltage	-0.5 to +22	V
V _I	DC Input Voltage	-0.5 to +18	V
I _I	DC Input Current	± 10	mA
P _D	Power Dissipation per Package	200	mW
	Power Dissipation per Output Transistor	100	mW
T _{op}	Operating Temperature	-55 to +125	°C
T _{stg}	Storage Temperature	-65 to +150	°C

Absolute Maximum Ratings are those values beyond which damage to the device may occur. Functional operation under these conditions is not implied.
All voltage values are referred to V_{SS} pin voltage.

RECOMMENDED OPERATING CONDITIONS

Symbol	Parameter	Value	Unit
V _{DD}	Supply Voltage	3 to 20	V
V _I	Input Voltage	-0.5 to 15V	V
T _{op}	Operating Temperature	-55 to 125	°C

DC SPECIFICATIONS

Symbol	Parameter	Test Condition				Value						Unit	
		V _I (V)	V _O (V)	I _{oI} (μ A)	V _{DD} (V)	T _A = 25°C			-40 to 85°C		-55 to 125°C		
						Min.	Typ.	Max.	Min.	Max.	Min.		Max.
I _L	Quiescent Current	0/5			5		0.02	1		30		30	μ A
		0/10			10		0.02	2		60		60	
		0/15			15		0.02	4		120		120	
		0/20			20		0.04	20		600		600	
V _{OH}	High Level Output Voltage	0/5		<1	5	4.95			4.95		4.95		V
		0/10		<1	10	9.95			9.95		9.95		
		0/15		<1	15	14.95			14.95		14.95		
V _{OL}	Low Level Output Voltage	5/0		<1	5		0.05			0.05		0.05	V
		10/0		<1	10		0.05			0.05		0.05	
		15/0		<1	15		0.05			0.05		0.05	
V _{IH}	High Level Input Voltage		0.5/4.5	<1	5	4			4		4		V
			1/9	<1	10	8			8		8		
			1.5/13.5	<1	15	12			12		12		
V _{IL}	Low Level Input Voltage		4.5/0.5	<1	5			1		1		1	V
			9/1	<1	10			2		2		2	
			13.5/1.5	<1	15			3		3		3	
I _{OH}	Output Drive Current	0/5	2.5	<1	5	-1.25	-6.4		-0.42		-0.42		mA
		0/5	4.6	<1	5	-0.51	-1.6		-0.38		-0.38		
		0/10	9.5	<1	10	-1.25	-3.6		-1		-1		
		0/15	13.5	<1	15	-3.75	-12		-3		-3		
I _{OL}	Output Sink Current	0/5	0.4	<1	5	3.2	6.4		2.6		2.6		mA
		0/10	0.5	<1	10	8	16		6.6		6.6		
		0/15	1.5	<1	15	24	48		19		19		
I _I	Input Leakage Current	0/18	Any Input		18		$\pm 10^{-5}$	± 0.1		± 1		± 1	μ A
C _I	Input Capacitance		Any Input				5	7.5					pF

The Noise Margin for both "1" and "0" level is: 1V min. with V_{DD}=5V, 2V min. with V_{DD}=10V, 2.5V min. with V_{DD}=15V

HCF4049UB

DYNAMIC ELECTRICAL CHARACTERISTICS ($T_{amb} = 25^{\circ}\text{C}$, $C_L = 50\text{pF}$, $R_L = 200\text{K}\Omega$, $t_r = t_f = 20\text{ ns}$)

Symbol	Parameter	Test Condition			Value (*)			Unit
		V_{DD} (V)	V_I (V)		Min.	Typ.	Max.	
t_{TLH}	Output Transition Time	5	5			80	160	ns
		10	10			40	80	
		15	15			30	60	
t_{THL}	Output Transition Time	5	5			30	60	ns
		10	10			20	40	
		15	15			15	30	
t_{PLH}	Propagation Delay Time	5	5			60	120	ns
		10	10			32	65	
		5	10			45	90	
		15	15			25	50	
		5	15			45	90	
t_{PHL}	Propagation Delay Time	5	5			32	65	ns
		10	10			20	40	
		5	10			15	30	
		15	15			15	30	
		5	15			10	20	

(*) Typical temperature coefficient for all V_{DD} value is 0.3%/°C.

TEST CIRCUIT

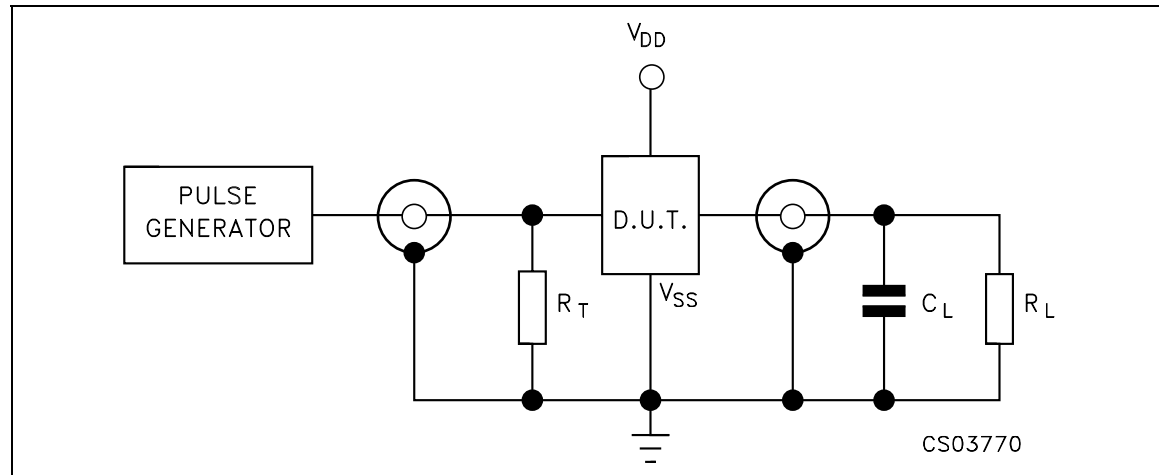

$C_L = 50\text{pF}$ or equivalent (includes jig and probe capacitance)

$R_L = 200\text{K}\Omega$

$R_T = Z_{OUT}$ of pulse generator (typically 50Ω)

Plastic DIP-16 (0.25) MECHANICAL DATA

DIM.	mm.			inch		
	MIN.	TYP	MAX.	MIN.	TYP.	MAX.
a1	0.51			0.020		
B	0.77		1.65	0.030		0.065
b		0.5			0.020	
b1		0.25			0.010	
D			20			0.787
E		8.5			0.335	
e		2.54			0.100	
e3		17.78			0.700	
F			7.1			0.280
I			5.1			0.201
L		3.3			0.130	
Z			1.27			0.050

