



STP20NM60-STP20NM60FP-STW20NM60 STB20NM60 - STB20NM60-1

N-CHANNEL 600V - 0.25Ω - 20A TO-220/FP/D²/I²PAK/TO-247
MDmesh™ MOSFET

Table 1: General Features

TYPE	V _{DSS}	R _{DS(on)}	I _D
STP20NM60	600 V	< 0.29 Ω	20 A
STP20NM60FP	600 V	< 0.29 Ω	20 A
STB20NM60	600 V	< 0.29 Ω	20 A
STB20NM60-1	600 V	< 0.29 Ω	20 A
STW20NM60	600 V	< 0.29 Ω	20 A

- TYPICAL R_{DS(on)} = 0.25 Ω
- HIGH dv/dt AND AVALANCHE CAPABILITIES
- 100% AVALANCHE TESTED
- LOW INPUT CAPACITANCE AND GATE CHARGE
- LOW GATE INPUT RESISTANCE

DESCRIPTION

The MDmesh™ is a new revolutionary MOSFET technology that associates the Multiple Drain process with the Company's PowerMESH™ horizontal layout. The resulting product has an outstanding low on-resistance, impressively high dv/dt and excellent avalanche characteristics. The adoption of the Company's proprietary strip technique yields overall dynamic performance that is significantly better than that of similar competition's products.

APPLICATIONS

The MDmesh™ family is very suitable for increasing power density of high voltage converters allowing system miniaturization and higher efficiencies.

Figure 1: Package

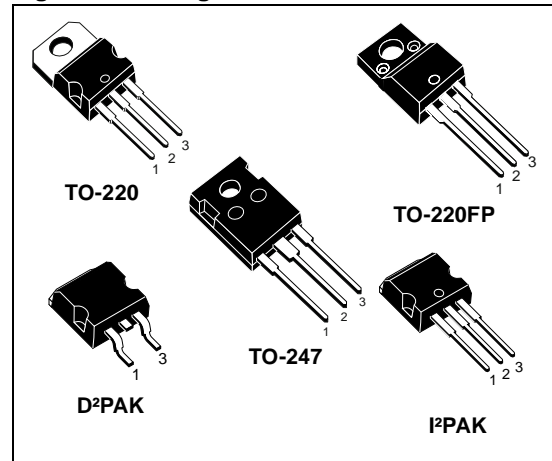

Figure 2: Internal Schematic Diagram

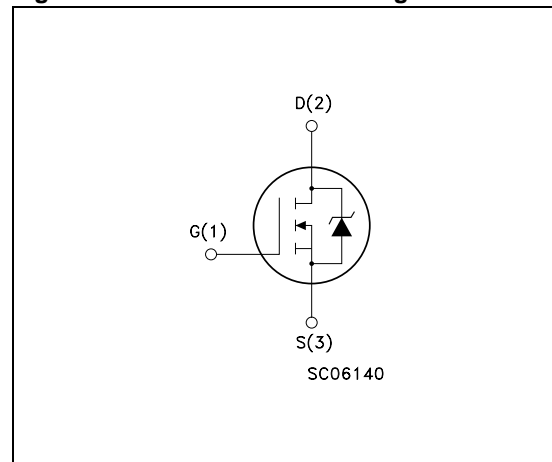

Table 2: Order Codes

SALES TYPE	MARKING	PACKAGE	PACKAGING
STP20NM60	P20NM60	TO-220	TUBE
STP20NM60FP	P20NM60FP	TO-220FP	TUBE
STB20NM60T4	B20NM60	D ² PAK	TAPE & REEL
STB20NM60-1	B20NM60	I ² PAK	TUBE
STW20NM60	W20NM60	TO-247	TUBE

Rev.2

STP20NM60 - STP20NM60FP - STB20NM60 - STW20NM60 - STB20NM60-1

Table 3: Absolute Maximum ratings

Symbol	Parameter	Value		Unit
		TO-220/D ² PAK/ I ² PAK/TO-247	TO-220FP	
V _{DS}	Drain-source Voltage (V _{GS} = 0)	600		V
V _{DGR}	Drain-gate Voltage (R _{GS} = 20 kΩ)	600		V
V _{GS}	Gate- source Voltage	±30		V
I _D	Drain Current (continuous) at T _C = 25°C	20	20 (*)	A
I _D	Drain Current (continuous) at T _C = 100°C	12.6	12.6 (*)	A
I _{DM} (•)	Drain Current (pulsed)	80	80 (*)	A
P _{TOT}	Total Dissipation at T _C = 25°C	192	45	W
	Derating Factor	1.2	0.36	W/°C
dv/dt (1)	Peak Diode Recovery voltage slope	15		V/ns
V _{ISO}	Insulation Withstand Voltage (DC)	--	2500	V
T _{stg}	Storage Temperature	-65 to 150		°C
T _j	Max. Operating Junction Temperature	150		°C

(•) Pulse width limited by safe operating area

(1) I_{SD} ≤ 20 A, di/dt ≤ 400 A/μs, V_{DD} ≤ V_{(BR)/DSS}, T_j ≤ T_{JMAX}

(*) Limited only by maximum temperature allowed

Table 4: Thermal Data

		TO-220/D ² PAK/ I ² PAK/TO-247	TO-220FP	Unit
R _{thj-case}	Thermal Resistance Junction-case Max	0.65	2.8	°C/W
R _{thj-amb}	Thermal Resistance Junction-ambient Max	62.5		°C/W
T _l	Maximum Lead Temperature For Soldering Purpose	300		°C

Table 5: Avalanche Characteristics

Symbol	Parameter	Max. Value	Unit
I _{AR}	Avalanche Current, Repetitive or Not-Repetitive (pulse width limited by T _j max)	10	A
E _{AS}	Single Pulse Avalanche Energy (starting T _j = 25 °C, I _D = I _{AR} , V _{DD} = 50 V)	650	mJ

ELECTRICAL CHARACTERISTICS (T_{CASE} = 25°C UNLESS OTHERWISE SPECIFIED)

Table 6: On/Off

Symbol	Parameter	Test Conditions	Min.	Typ.	Max.	Unit
V _{(BR)DSS}	Drain-source Breakdown Voltage	I _D = 250 μA, V _{GS} = 0	600			V
I _{DSS}	Zero Gate Voltage Drain Current (V _{GS} = 0)	V _{DS} = Max Rating V _{DS} = Max Rating, T _C = 125°C			1 10	μA μA
I _{GSS}	Gate-body Leakage Current (V _{DS} = 0)	V _{GS} = ± 30V			±100	μA
V _{GS(th)}	Gate Threshold Voltage	V _{DS} = V _{GS} , I _D = 250 μA	3	4	5	V
R _{DS(on)}	Static Drain-source On Resistance	V _{GS} = 10V, I _D = 10 A		0.25	0.29	Ω

ELECTRICAL CHARACTERISTICS (CONTINUED)

Table 7: Dynamic

Symbol	Parameter	Test Conditions	Min.	Typ.	Max.	Unit
g_{fs} (1)	Forward Transconductance	$V_{DS} > I_{D(on)} \times R_{DS(on)max}$, $I_D = 10\text{ A}$		11		S
C_{iss} C_{oss} C_{rss}	Input Capacitance Output Capacitance Reverse Transfer Capacitance	$V_{DS} = 25\text{ V}$, $f = 1\text{ MHz}$, $V_{GS} = 0$		1500 350 35		pF pF pF
$C_{oss\ eq.}$ (3)	Equivalent Output Capacitance	$V_{GS} = 0\text{ V}$, $V_{DS} = 0\text{ V to } 400\text{ V}$		215		pF
$t_{d(on)}$ t_r $t_{d(off)}$ t_f t_c	Turn-on Delay Time Rise Time Turn-off Delay Time Fall Time Cross-over Time	$V_{DD} = 200\text{ V}$, $I_D = 10\text{ A}$ $R_G = 4.7\Omega$, $V_{GS} = 10\text{ V}$ (Resistive Load see, Figure 3) $V_{DD} = 480\text{ V}$, $I_D = 20\text{ A}$ (See test circuit, Figure 5)		25 20 6 11 21		ns ns ns ns ns
Q_g Q_{gs} Q_{gd}	Total Gate Charge Gate-Source Charge Gate-Drain Charge	$V_{DD} = 400\text{ V}$, $I_D = 20\text{ A}$, $V_{GS} = 10\text{ V}$		39 10 20	54	nC nC nC
R_g	Gate Input Resistance	$f = 1\text{ MHz}$ Gate DC Bias = 0 Test Signal Level = 20 mV Open Drain		1.6		Ω

Table 8: Source Drain Diode

Symbol	Parameter	Test Conditions	Min.	Typ.	Max.	Unit
I_{SD} I_{SDM} (2)	Source-drain Current Source-drain Current (pulsed)				20 80	A A
V_{SD} (1)	Forward On Voltage	$I_{SD} = 20\text{ A}$, $V_{GS} = 0$			1.5	V
t_{rr} Q_{rr} I_{RRM}	Reverse Recovery Time Reverse Recovery Charge Reverse Recovery Current	$I_{SD} = 20\text{ A}$, $di/dt = 100\text{ A}/\mu\text{s}$ $V_{DD} = 100\text{ V}$, $T_j = 25^\circ\text{C}$ (see test circuit, Figure 5)		390 5 25		ns μC A
t_{rr} Q_{rr} I_{RRM}	Reverse Recovery Time Reverse Recovery Charge Reverse Recovery Current	$I_{SD} = 20\text{ A}$, $di/dt = 100\text{ A}/\mu\text{s}$ $V_{DD} = 100\text{ V}$, $T_j = 150^\circ\text{C}$ (see test circuit, Figure 5)		510 6.5 26		ns μC A

Note: 1. Pulsed: Pulse duration = 300 μs , duty cycle 1.5 %.
 2. Pulse width limited by safe operating area.
 3. $C_{oss\ eq.}$ is defined as a constant equivalent capacitance giving the same charging time as C_{oss} when V_{DS} increases from 0 to 80% V_{DSS} .

Figure 3: Safe Operating Area for TO-220/ D²PAK/I²PAK

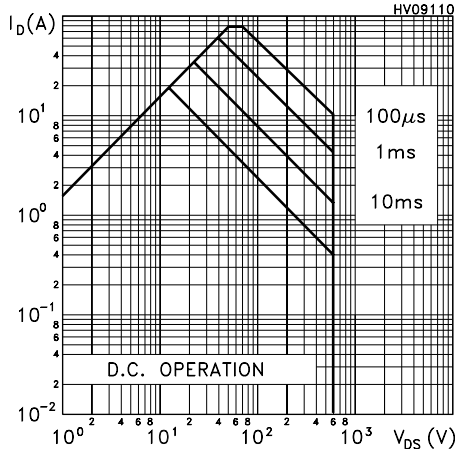

Figure 4: Safe Operating Area for TO-220FP

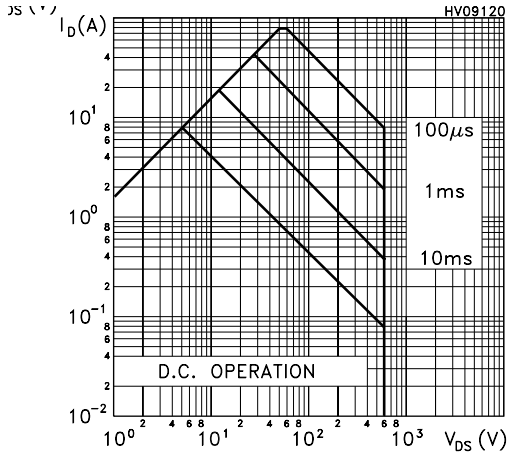

Figure 5: Safe Operating Area for TO-247

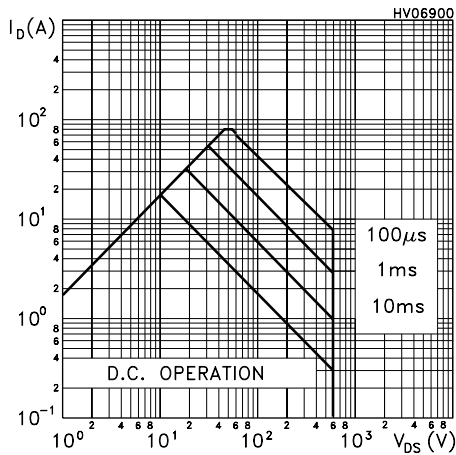

Figure 6: Thermal Impedance for TO-220/ D²PAK/I²PAK

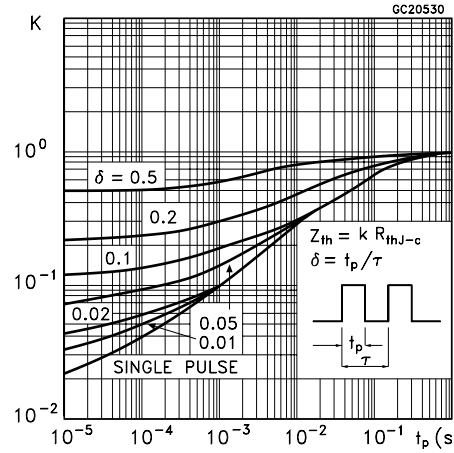

Figure 7: Thermal Impedance for TO-220FP

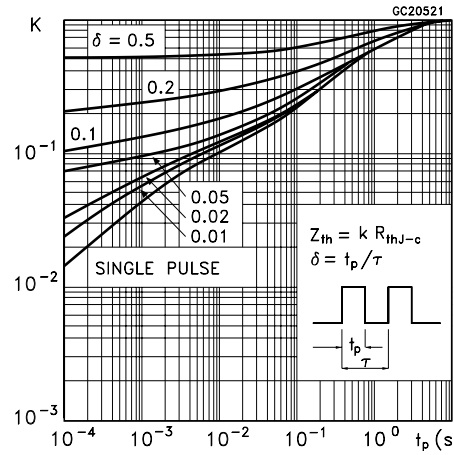

Figure 8: Thermal Impedance for TO-247

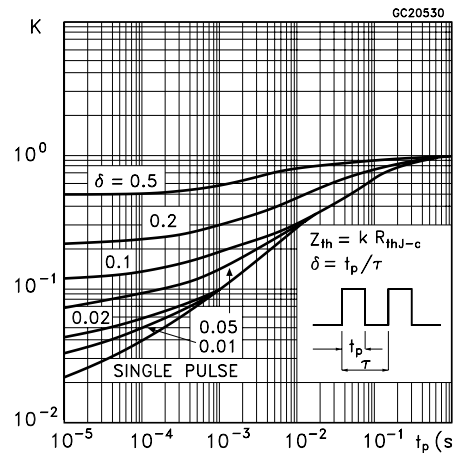

Figure 9: Output Characteristics

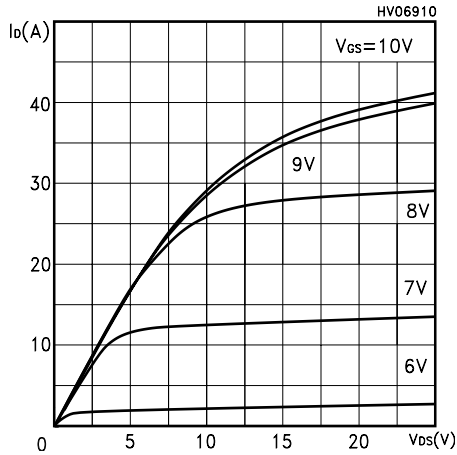

Figure 10: Transconductance

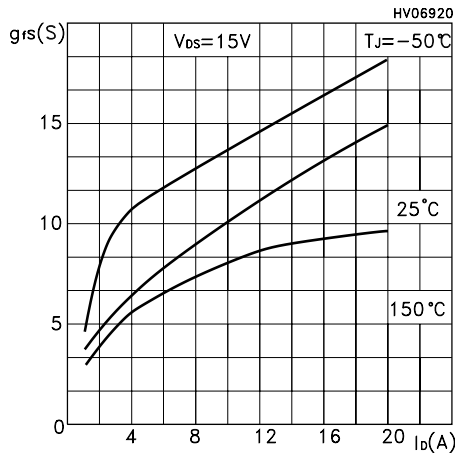

Figure 11: Transfer Characteristics

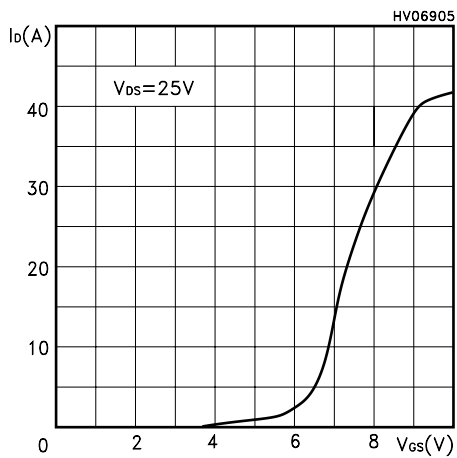

Figure 12: Gate Charge vs Gate-source Voltage

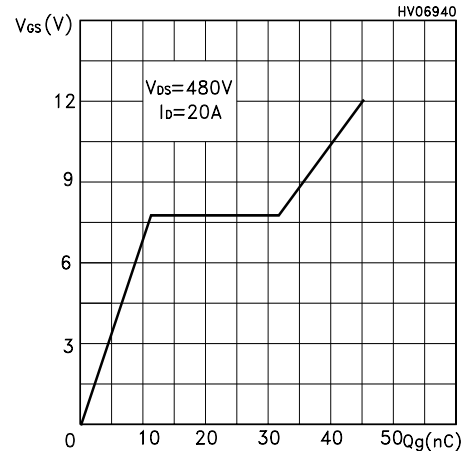

Figure 13: Normalized Gate Threshold Voltage vs Temp.

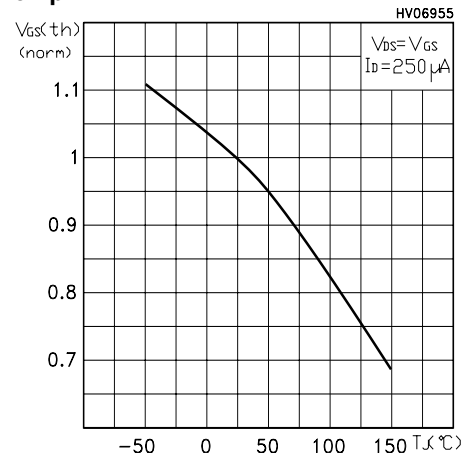

Figure 14: Static Drain-source On Resistance

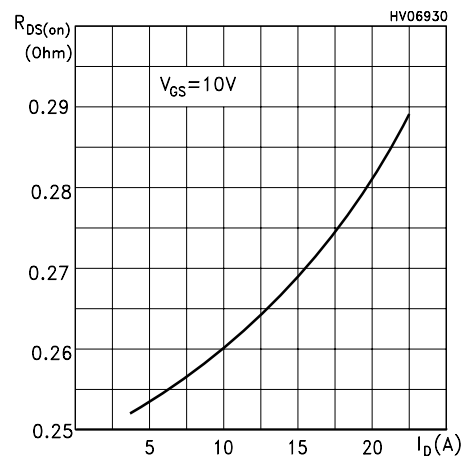

Figure 15: Capacitance Variations

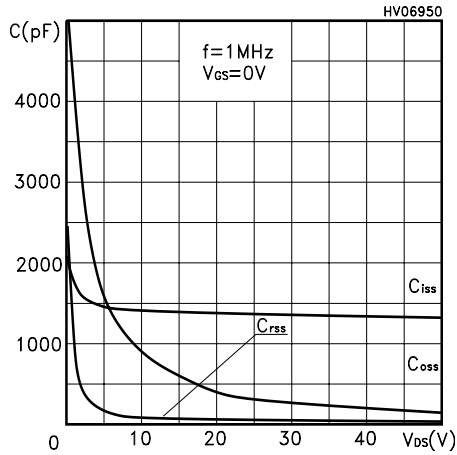

Figure 17: Source-drain Diode Forward Characteristics

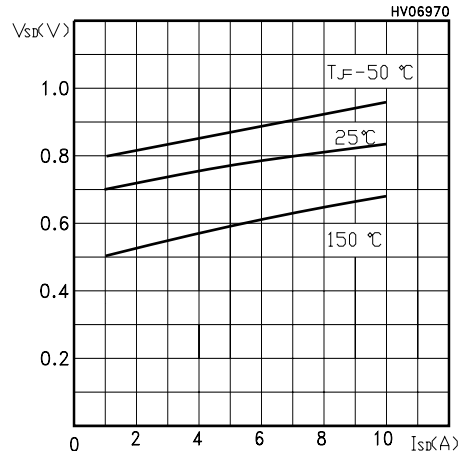

Figure 16: Normalized On Resistance vs Temperature

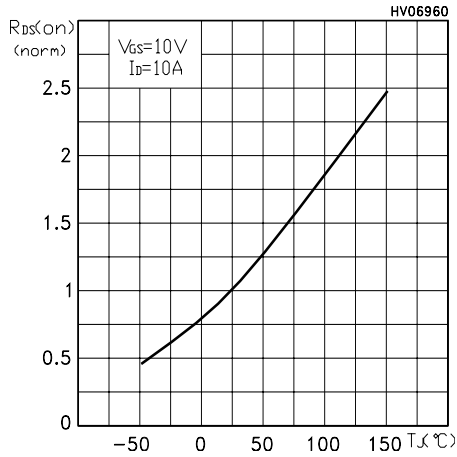

Figure 18: Unclamped Inductive Load Test Circuit

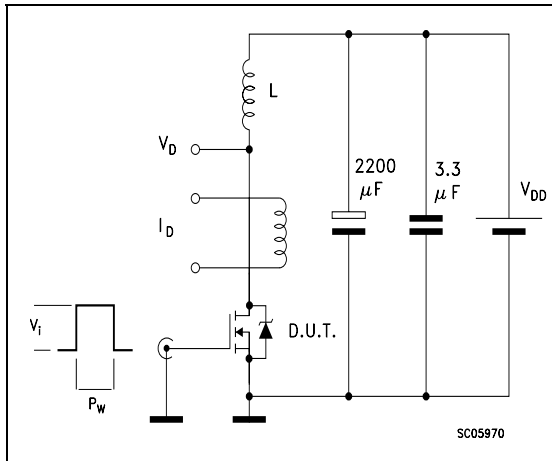

Figure 21: Unclamped Inductive Waform

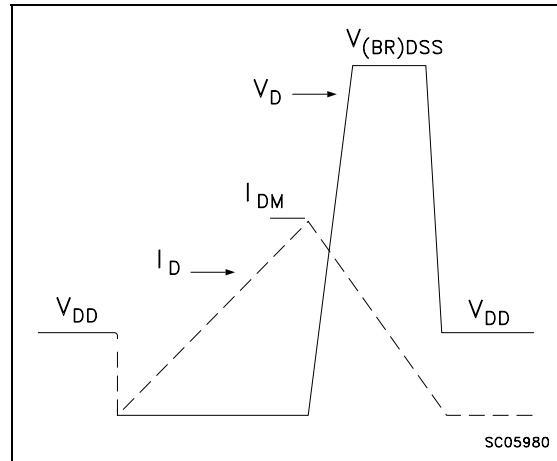

Figure 19: Switching Times Test Circuit For Resistive Load

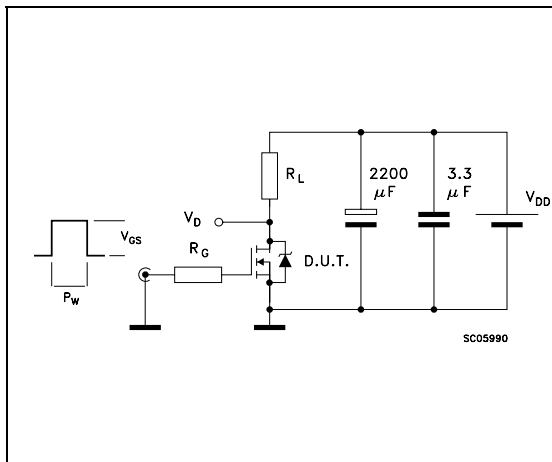

Figure 22: Gate Charge Test Circuit

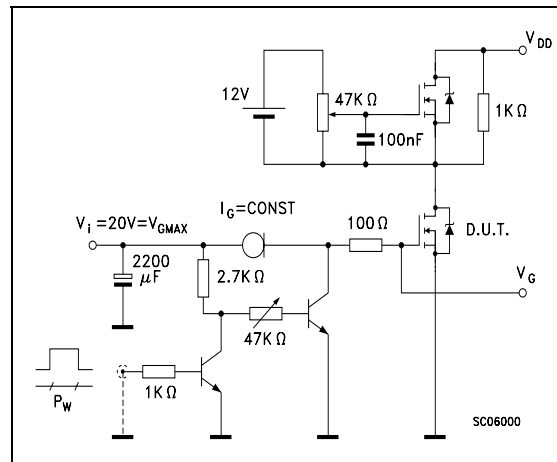
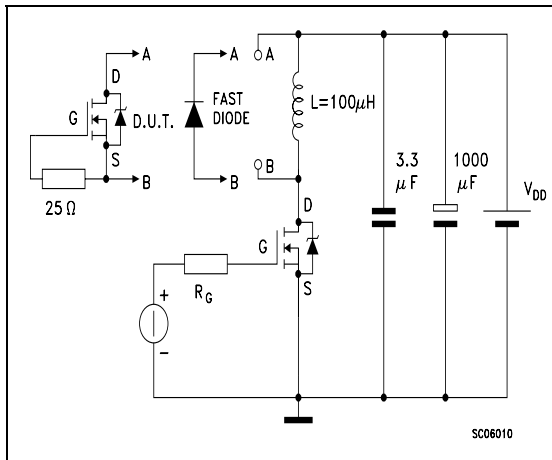
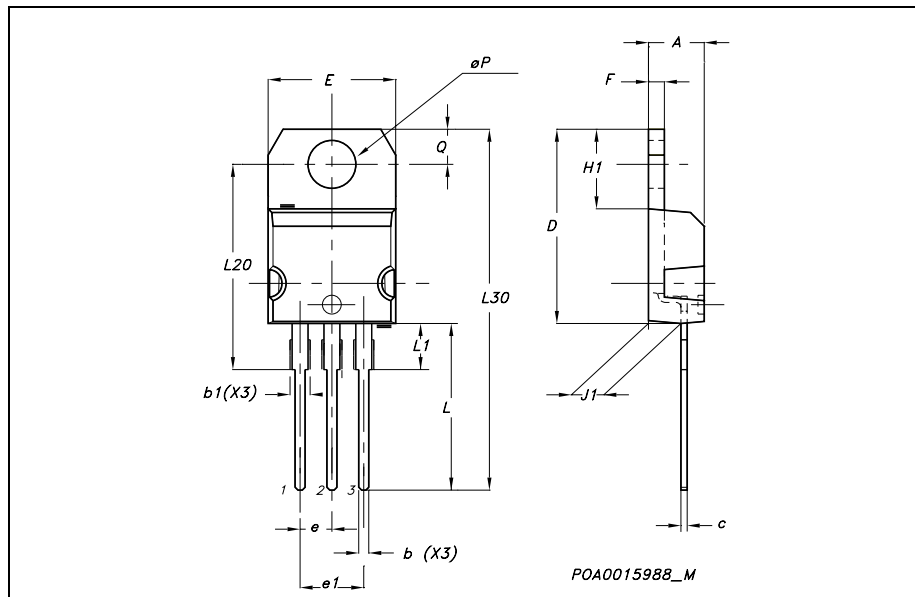

Figure 20: Test Circuit For Inductive Load Switching and Diode Recovery Times



TO-220 MECHANICAL DATA

DIM.	mm.			inch		
	MIN.	TYP.	MAX.	MIN.	TYP.	MAX.
A	4.40		4.60	0.173		0.181
b	0.61		0.88	0.024		0.034
b1	1.15		1.70	0.045		0.066
c	0.49		0.70	0.019		0.027
D	15.25		15.75	0.60		0.620
E	10		10.40	0.393		0.409
e	2.40		2.70	0.094		0.106
e1	4.95		5.15	0.194		0.202
F	1.23		1.32	0.048		0.052
H1	6.20		6.60	0.244		0.256
J1	2.40		2.72	0.094		0.107
L	13		14	0.511		0.551
L1	3.50		3.93	0.137		0.154
L20		16.40			0.645	
L30		28.90			1.137	
øP	3.75		3.85	0.147		0.151
Q	2.65		2.95	0.104		0.116



TO-220FP MECHANICAL DATA

DIM.	mm.			inch		
	MIN.	TYP.	MAX.	MIN.	TYP.	MAX.
A	4.4		4.6	0.173		0.181
B	2.5		2.7	0.098		0.106
D	2.5		2.75	0.098		0.108
E	0.45		0.7	0.017		0.027
F	0.75		1	0.030		0.039
F1	1.15		1.7	0.045		0.067
F2	1.15		1.7	0.045		0.067
G	4.95		5.2	0.195		0.204
G1	2.4		2.7	0.094		0.106
H	10		10.4	0.393		0.409
L2		16			0.630	
L3	28.6		30.6	1.126		1.204
L4	9.8		10.6	.0385		0.417
L5	2.9		3.6	0.114		0.141
L6	15.9		16.4	0.626		0.645
L7	9		9.3	0.354		0.366
Ø	3		3.2	0.118		0.126

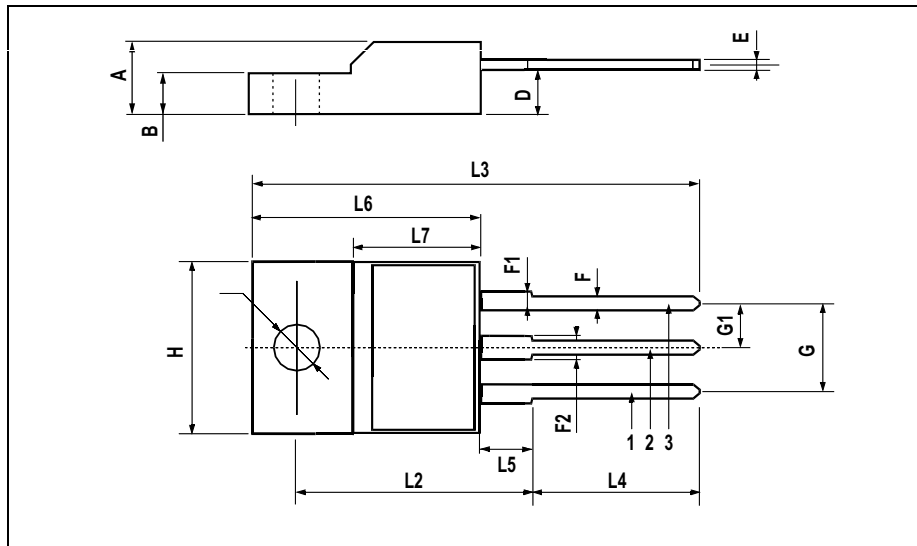

TO-263 (D²PAK) MECHANICAL DATA

DIM.	mm.			inch		
	MIN.	TYP.	MAX.	MIN.	TYP.	MAX.
A	4.32		4.57	0.178		0.180
A1	0.00		0.25	0.00		0.009
b	0.71		0.91	0.028		0.350
b2	1.15		1.40	0.045		0.055
c	0.46		0.61	0.018		0.024
c2	1.22		1.40	0.048		0.055
D	8.89	9.02	9.40	0.350	0.355	0.370
D1	8.01			0.315		
E	10.04		10.28	0.395		0.404
e		2.54			0.010	
H	13.10		13.70	0.515		0.540
L	1.30		1.70	0.051		0.067
L1	1.15		1.39	0.045		0.054
L2	1.27		1.77	0.050		0.069
L4	2.70		3.10	0.106		0.122
V2	0°		8°	0°		8°

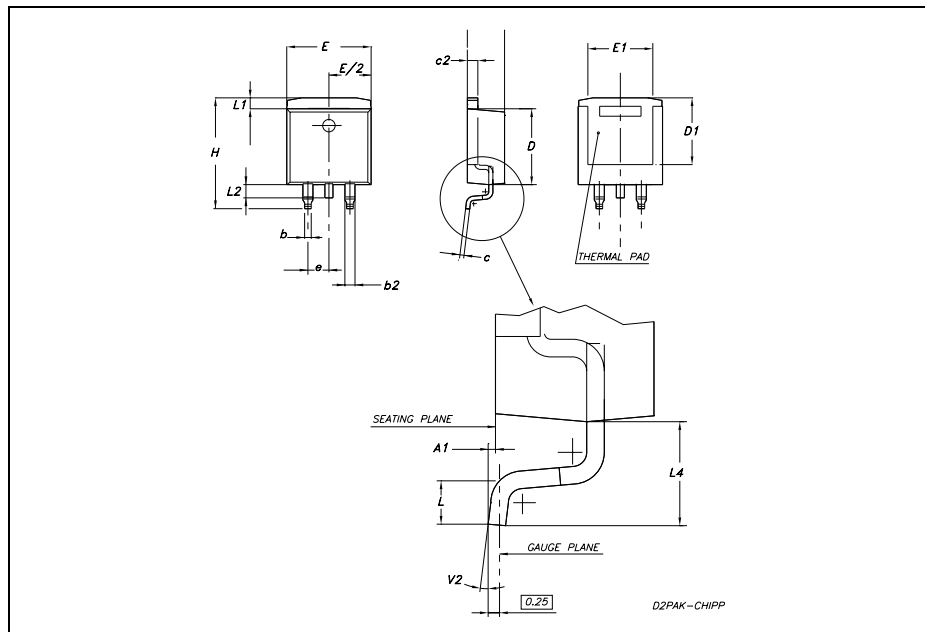

TO-262 (I²PAK) MECHANICAL DATA

DIM.	mm.			inch		
	MIN.	TYP.	MAX.	MIN.	TYP.	MAX.
A	4.40		4.60	0.173		0.181
A1	2.40		2.72	0.094		0.107
b	0.61		0.88	0.024		0.034
b1	1.14		1.70	0.044		0.066
c	0.49		0.70	0.019		0.027
c2	1.23		1.32	0.048		0.052
D	8.95		9.35	0.352		0.368
e	2.40		2.70	0.094		0.106
e1	4.95		5.15	0.194		0.202
E	10		10.40	0.393		0.410
L	13		14	0.511		0.551
L1	3.50		3.93	0.137		0.154
L2	1.27		1.40	0.050		0.055

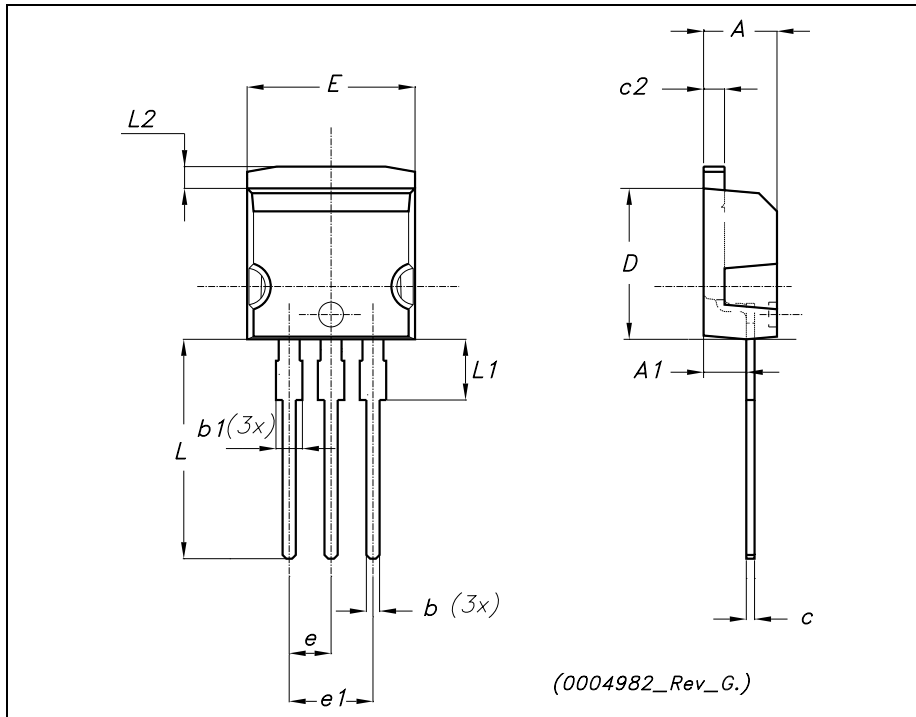

D²PAK FOOTPRINT

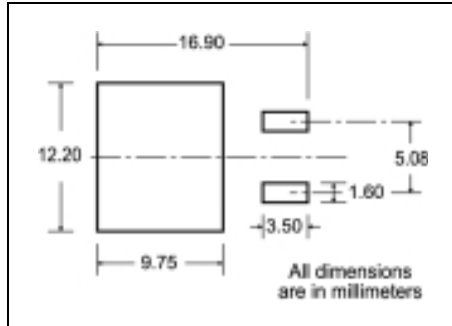

TUBE SHIPMENT (no suffix)*

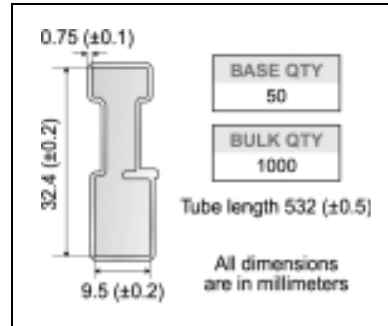

TAPE AND REEL SHIPMENT (suffix "T4")*

Diagram showing the tape mechanical data. It includes a circular reel view with dimensions A, B, C, D, and G. A note indicates a 40 mm min. access hole at the slot location. Another note indicates a tape slot in the core for tape start with a 2.5 mm min. width. The full radius is also indicated. A side view shows dimensions T, N, and G measured at the hub.

TAPE MECHANICAL DATA

DIM.	mm		inch	
	MIN.	MAX.	MIN.	MAX.
A0	10.5	10.7	0.413	0.421
B0	15.7	15.9	0.618	0.626
D	1.5	1.6	0.059	0.063
D1	1.59	1.61	0.062	0.063
E	1.65	1.85	0.065	0.073
F	11.4	11.6	0.449	0.456
K0	4.8	5.0	0.189	0.197
P0	3.9	4.1	0.153	0.161
P1	11.9	12.1	0.468	0.476
P2	1.9	2.1	0.075	0.082
R	50		1.574	
T	0.25	0.35	0.0098	0.0137
W	23.7	24.3	0.933	0.956

REEL MECHANICAL DATA

DIM.	mm		inch	
	MIN.	MAX.	MIN.	MAX.
A		330		12.992
B	1.5		0.059	
C	12.8	13.2	0.504	0.520
D	20.2		0.795	
G	24.4	26.4	0.960	1.039
N	100		3.937	
T		30.4		1.197

BASE QTY	BULK QTY
1000	1000

Diagram showing the reel mechanical data. It includes a top view of the reel with dimensions A, B, C, D, E, F, G, H, I, J, K, L, M, N, O, P, Q, R, S, T, U, V, W, X, Y, Z. A note indicates a 10 pitches cumulative tolerance on tape of +/- 0.2 mm. The center line of the cavity is also indicated. The user direction of feed is shown. A side view shows the top cover tape and the center line of the cavity. The feed direction is also shown. The bending radius is indicated as R min.

* on sales type

TO-247 MECHANICAL DATA

DIM.	mm.			inch		
	MIN.	TYP.	MAX.	MIN.	TYP.	MAX.
A	4.85		5.15	0.19		0.20
A1	2.20		2.60	0.086		0.102
b	1.0		1.40	0.039		0.055
b1	2.0		2.40	0.079		0.094
b2	3.0		3.40	0.118		0.134
c	0.40		0.80	0.015		0.03
D	19.85		20.15	0.781		0.793
E	15.45		15.75	0.608		0.620
e		5.45			0.214	
L	14.20		14.80	0.560		0.582
L1	3.70		4.30	0.14		0.17
L2		18.50			0.728	
øP	3.55		3.65	0.140		0.143
øR	4.50		5.50	0.177		0.216
S		5.50			0.216	

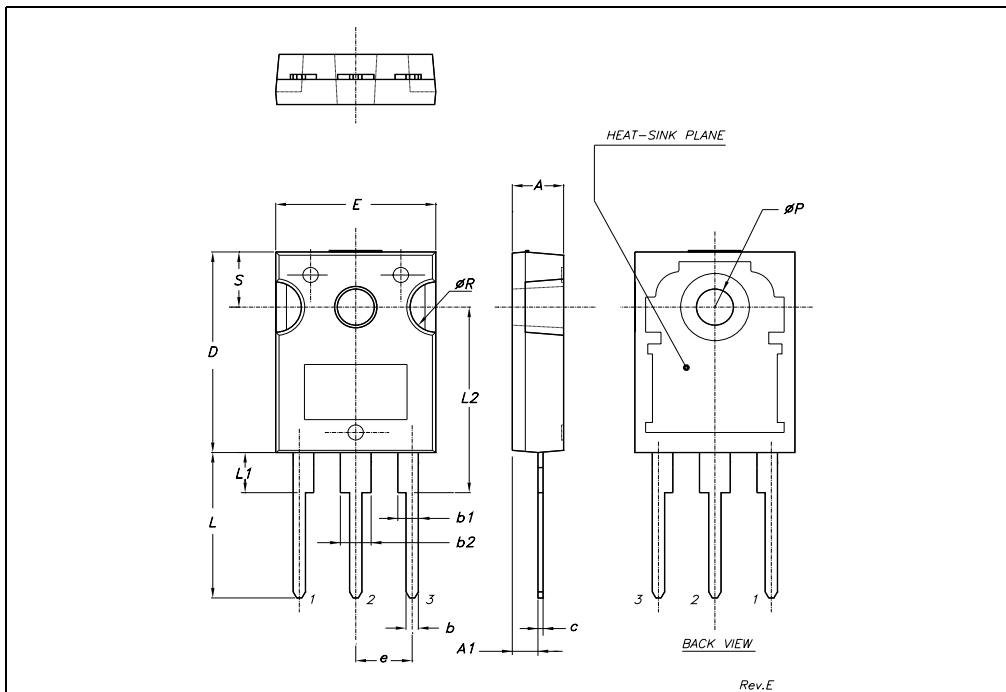

Table 9: Revision History

Date	Revision	Description of Changes
26-Jul-2004	1	First Release
17-Feb-2005	2	Insert the TO-247 package

Information furnished is believed to be accurate and reliable. However, STMicroelectronics assumes no responsibility for the consequences of use of such information nor for any infringement of patents or other rights of third parties which may result from its use. No license is granted by implication or otherwise under any patent or patent rights of STMicroelectronics. Specifications mentioned in this publication are subject to change without notice. This publication supersedes and replaces all information previously supplied. STMicroelectronics products are not authorized for use as critical components in life support devices or systems without express written approval of STMicroelectronics.

The ST logo is a registered trademark of STMicroelectronics

All other names are the property of their respective owners

© 2005 STMicroelectronics - All Rights Reserved

STMicroelectronics group of companies

Australia - Belgium - Brazil - Canada - China - Czech Republic - Finland - France - Germany - Hong Kong - India - Israel - Italy - Japan - Malaysia - Malta - Morocco - Singapore - Spain - Sweden - Switzerland - United Kingdom - United States of America

