



# STP10NK80ZFP STP10NK80Z - STW10NK80Z

N-CHANNEL 800V - 0.78Ω - 9A - TO-220/FP-TO-247  
Zener-Protected SuperMESH™ MOSFET

## General features

Type	V <sub>DSS</sub>	R <sub>DS(on)</sub>	I <sub>D</sub>	P <sub>w</sub>
STW10NK80Z	800 V	<0.90 Ω	9 A	160 W
STP10NK80Z	800 V	<0.90 Ω	9 A	160 W
STP10NK80ZFP	800 V	<0.90 Ω	9 A	40 W

- EXTREMELY HIGH dv/dt CAPABILITY
- 100% AVALANCHE TESTED
- GATE CHARGE MINIMIZED
- VERY LOW INTRINSIC CAPACITANCES
- VERY GOOD MANUFACTURING REPEABILITY

## Description

The SuperMESH™ series is obtained through an extreme optimization of ST's well established strip-based PowerMESH™ layout. In addition to pushing on-resistance significantly down, special care is taken to ensure a very good dv/dt capability for the most demanding applications.

## Applications

- HIGH CURRENT, HIGH SPEED SWITCHING
- SWITCH MODE POWER SUPPLIES
- DC-AC CONVERTERS FOR WELDING, UPS AND MOTOR DRIVE

## Order codes

Sales Type	Marking	Package	Packaging
STP10NK80Z	P10NK80Z	TO-220	TUBE
STP10NK80ZFP	P10NK80ZFP	TO-220FP	TUBE
STW10NK80Z	W10NK80Z	TO-247	TUBE

## Package

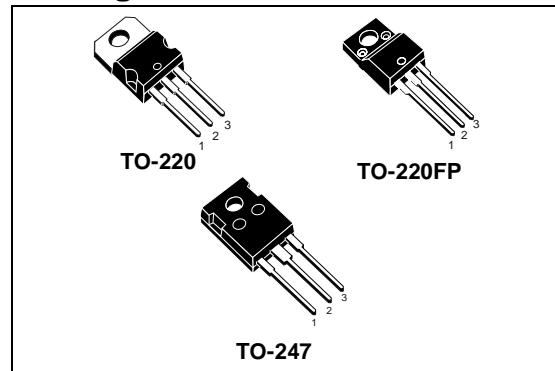

## Internal schematic diagram

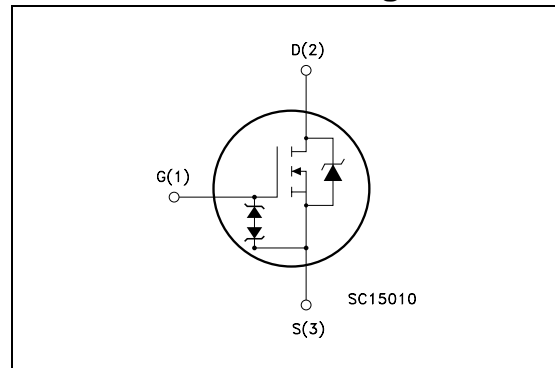

# 1 Electrical ratings

**Table 1. Absolute maximum ratings**

Symbol	Parameter	Value		Unit
		TO-220/ TO-247	TO-220FP	
$V_{DS}$	Drain-Source Voltage ( $V_{GS} = 0$ )	800		V
$V_{DGR}$	Drain-gate Voltage ( $R_{GS} = 20k\Omega$ )	800		V
$V_{GS}$	Gate-Source Voltage	$\pm 30$		V
$I_D$	Drain Current (continuous) at $T_C = 25^\circ\text{C}$	9	9 (Note 1)	A
$I_D$	Drain Current (continuous) at $T_C = 100^\circ\text{C}$	6	6 (Note 1)	A
$I_{DM}$ Note 2	Drain Current (pulsed)	36	36 (Note 1)	A
$P_{TOT}$	Total Dissipation at $T_C = 25^\circ\text{C}$	160	40	W
	Derating Factor	1.28	0.32	W/°C
Vesd(G-S)	G-S ESD (HBM C=100pF, R=1.5kΩ)	4		KV
dv/dt Note 3	Peak Diode Recovery voltage slope	4.5		V/ns
$V_{ISO}$	Insulation Withstand Voltage (DC)	--	2500	V
$T_j$ $T_{stg}$	Operating Junction Temperature Storage Temperature	-55 to 150		°C

**Table 2. Thermal data**

		TO-220	TO-220FP	TO-247	Unit
Rthj-case	Thermal Resistance Junction-case Max	0.78	3.1	0.78	°C/W
Rthj-amb	Thermal Resistance Junction-amb Max	62.5		50	°C/W
$T_l$	Maximum Lead Temperature For Soldering Purpose	300			°C

**Table 3. Avalanche characteristics**

Symbol	Parameter	Max Value	Unit
$I_{AR}$	Avalanche Current, repetitive or Not-Repetitive (pulse width limited by $T_j$ max)	9	A
$E_{AS}$	Single Pulse Avalanche Energy (starting $T_j=25^\circ\text{C}$ , $I_D=I_{AR}$ , $V_{DD}=50\text{V}$ )	290	mJ

## 2 Electrical characteristics

( $T_{CASE} = 25\text{ °C}$  unless otherwise specified)

**Table 4. On/off states**

Symbol	Parameter	Test Conditions	Min.	Typ.	Max.	Unit
$V_{(BR)DSS}$	Drain-Source Breakdown Voltage	$I_D = 1\text{ mA}$ , $V_{GS} = 0$	800			V
$I_{DSS}$	Zero Gate Voltage Drain Current ( $V_{GS} = 0$ )	$V_{DS} = \text{Max Rating}$ , $V_{DS} = \text{Max Rating}$ , $T_c = 125\text{ °C}$			1 50	$\mu\text{A}$ $\mu\text{A}$
$I_{GSS}$	Gate Body Leakage Current ( $V_{DS} = 0$ )	$V_{GS} = \pm 20\text{ V}$			$\pm 10$	$\mu\text{A}$
$V_{GS(th)}$	Gate Threshold Voltage	$V_{DS} = V_{GS}$ , $I_D = 100\text{ }\mu\text{A}$	3	3.75	4.5	V
$R_{DS(on)}$	Static Drain-Source On Resistance	$V_{GS} = 10\text{ V}$ , $I_D = 4.5\text{ A}$		0.78	0.9	$\Omega$

**Table 5. Dynamic**

Symbol	Parameter	Test Conditions	Min.	Typ.	Max.	Unit
$g_{fs}$ <i>Note 4</i>	Forward Transconductance	$V_{DS} = 15\text{ V}$ , $I_D = 4.5\text{ A}$		9.6		S
$C_{iss}$	Input Capacitance	$V_{DS} = 25\text{ V}$ , $f = 1\text{ MHz}$ , $V_{GS} = 0$		2180		pF
$C_{oss}$	Output Capacitance			205		pF
$C_{rss}$	Reverse Transfer Capacitance			38		pF
$C_{oss\text{ eq.}}$ <i>Note 5</i>	Equivalent Output Capacitance	$V_{GS} = 0$ , $V_{DS} = 0\text{ V to } 640\text{ V}$		105		pF
$Q_g$	Total Gate Charge	$V_{DD} = 640\text{ V}$ , $I_D = 9\text{ A}$		72	101	nC
$Q_{gs}$	Gate-Source Charge	$V_{GS} = 10\text{ V}$		12.5		nC
$Q_{gd}$	Gate-Drain Charge	(see Figure 19)		37		nC

**Table 6. Switching times**

Symbol	Parameter	Test Conditions	Min.	Typ.	Max.	Unit
$t_{d(on)}$	Turn-on Delay Time	$V_{DD} = 400\text{ V}$ , $I_D = 4.5\text{ A}$ , $R_G = 4.7\text{ }\Omega$ , $V_{GS} = 10\text{ V}$ (see Figure 20)		30		ns
$t_r$	Rise Time			20		ns
$t_{d(off)}$	Turn-off Delay Time	$V_{DD} = 400\text{ V}$ , $I_D = 4.5\text{ A}$ , $R_G = 4.7\text{ }\Omega$ , $V_{GS} = 10\text{ V}$ (see Figure 20)		65		ns
$t_f$	Fall Time			17		ns
$t_{r(voff)}$	Off-voltage Rise Time	$V_{DD} = 640\text{ V}$ , $I_D = 9\text{ A}$ , $R_G = 4.7\text{ }\Omega$ , $V_{GS} = 10\text{ V}$ (see Figure 20)		13		ns
$t_f$	Fall Time			10		ns
$t_c$	Cross-over Time			25		ns

**Table 7. Gate-source zener diode**

Symbol	Parameter	Test Conditions	Min.	Typ.	Max.	Unit
$BV_{GSO}$ <i>Note 6</i>	Gate-Source Breakdown Voltage	$I_{GS}=\pm 1\text{mA}$ (Open Drain)	30			V

**Table 8. Source drain diode**

Symbol	Parameter	Test Conditions	Min.	Typ.	Max.	Unit
$I_{SD}$	Source-drain Current				9	A
$I_{SDM}$ <i>Note 2</i>	Source-drain Current (pulsed)				36	A
$V_{SD}$ <i>Note 4</i>	Forward on Voltage	$I_{SD}=9\text{ A}, V_{GS}=0$			1.6	V
$t_{rr}$	Reverse Recovery Time	$I_{SD}=9\text{A}, di/dt = 100\text{A}/\mu\text{s},$ $V_{DD}=45\text{ V}, T_J=150^\circ\text{C}$		645		ns
$Q_{rr}$	Reverse Recovery Charge			6.4		$\mu\text{C}$
$I_{RRM}$	Reverse Recovery Current			20		A

(1) Limited only by maximum temperature allowed

(2) Pulse width limited by safe operating area

(3)  $I_{SD} \leq 9\text{A}$ ,  $di/dt \leq 200\text{A}/\mu\text{s}$ ,  $V_{DD} \leq V_{(BR)DSS}$ ,  $T_J \leq T_{JMAX}$

(4) Pulsed: pulse duration = 300 $\mu\text{s}$ , duty cycle 1.5%

(5)  $C_{oss\ 80\%}$  is defined as a constant equivalent capacitance giving the same charging time as  $C_{oss}$  when  $V_{DS}$  increases from 0 to 80%

(6) The built-in back-to-back Zener diodes have specifically been designed to enhance not only the device's ESD capability, but also to make them safely absorb possible voltage transients that may occasionally be applied from gate to source. In this respect the Zener voltage is appropriate to achieve an efficient and cost-effective intervention to protect the device's integrity. These integrated Zener diodes thus avoid the usage of external components.

## 2.1 Electrical characteristics (curves)

Figure 1. Safe Operating Area for TO-220

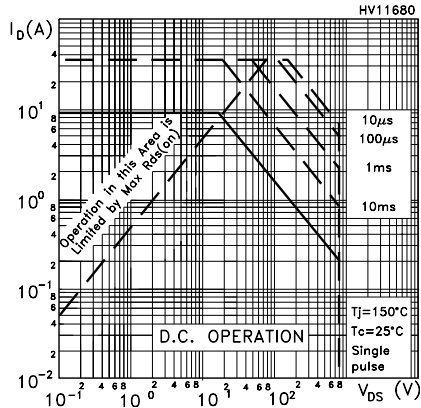

Figure 2. Thermal Impedance for TO-220

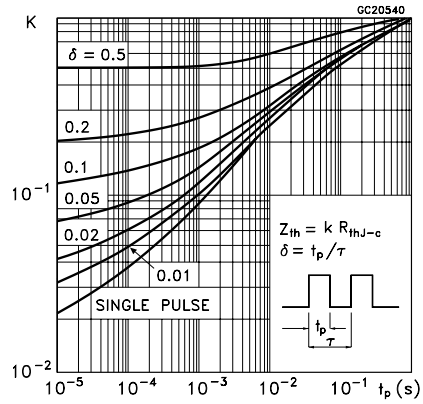

Figure 3. Safe Operating Area for TO-220FP

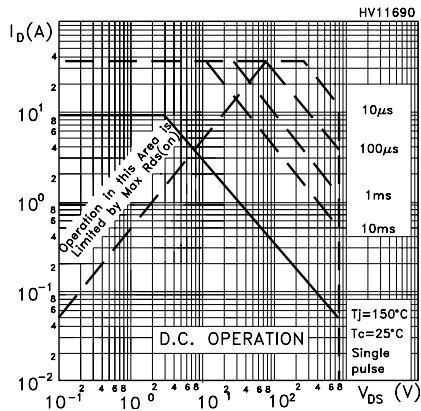

Figure 4. Thermal Impedance for TO-220FP

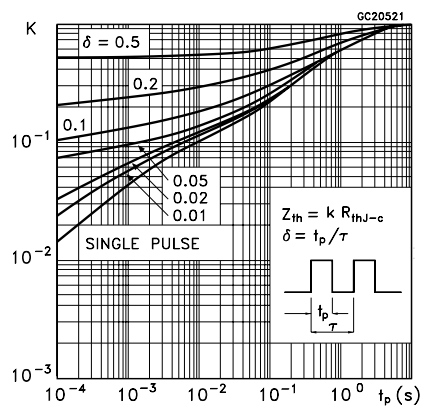

Figure 5. Safe Operating Area for TO-247

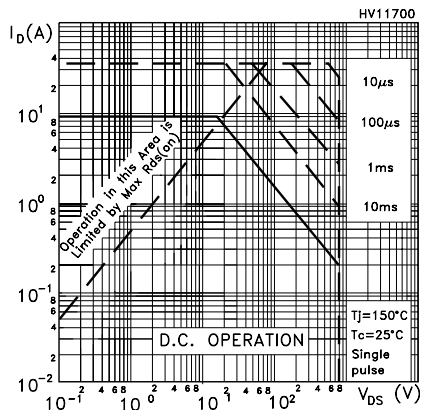

Figure 6. Thermal Impedance for TO-247

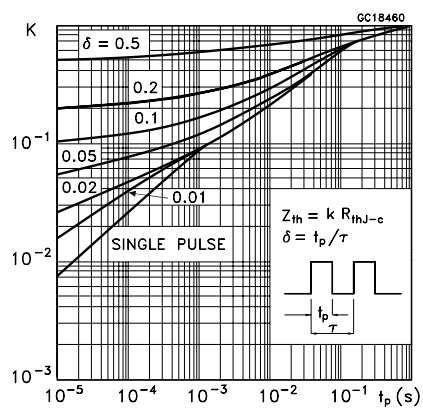

Figure 7. Output Characteristics

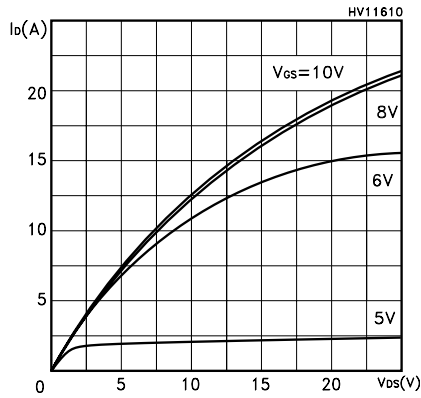

Figure 8. Transfer Characteristics

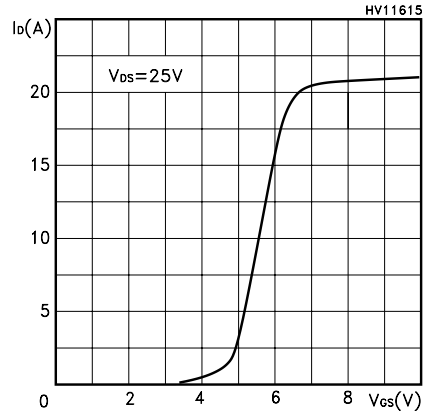

Figure 9. Transconductance

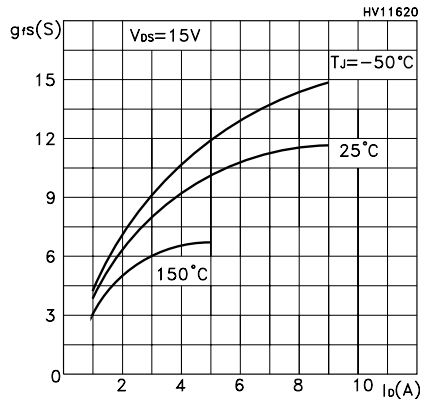

Figure 10. Static Drain-Source on Resistance

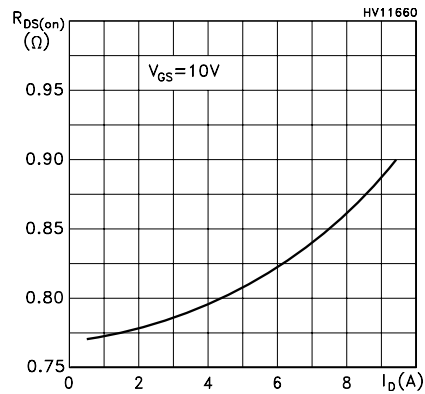

Figure 11. Gate Charge vs Gate -Source Voltage

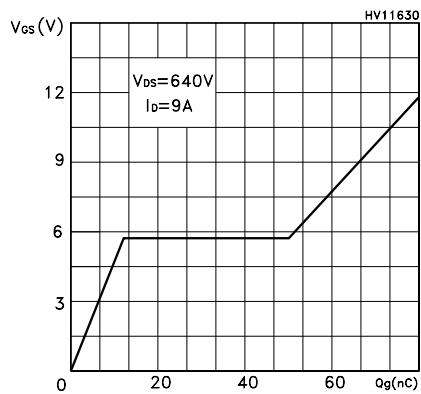
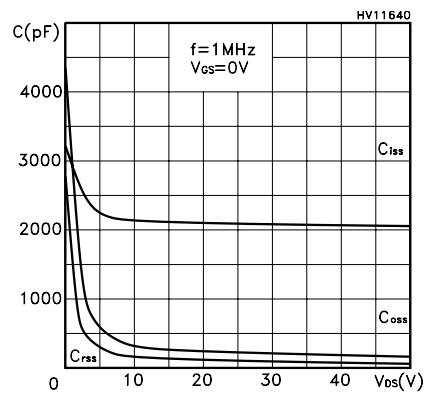
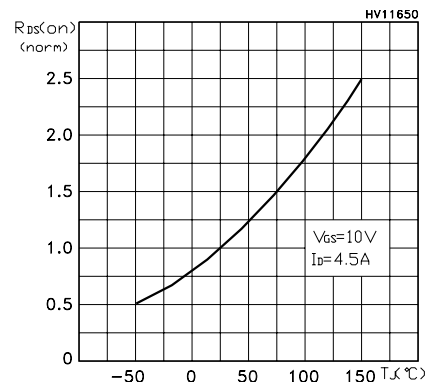
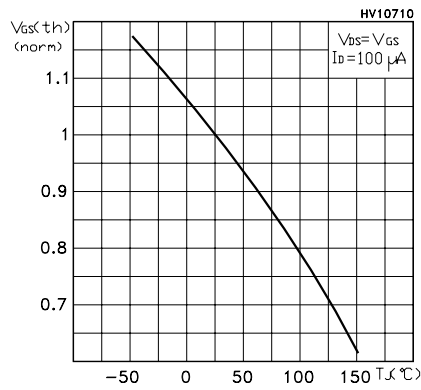

Figure 12. Capacitance Variations



**Figure 13. Normalized Gate Threshold Voltage vs Temperature**      **Figure 14. Normalized on Resistance vs Temperature**



**Figure 15. Source-drain Diode Forward Characteristics**

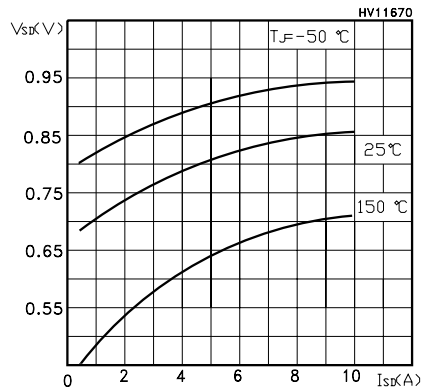

**Figure 16. Normalized BVDSS vs Temperature**

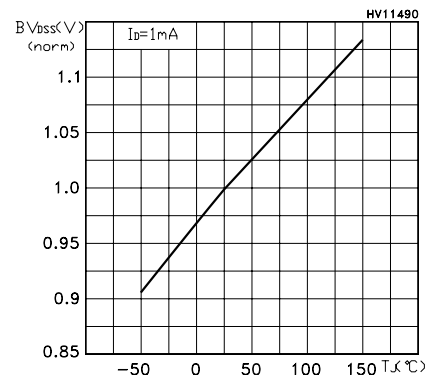

**Figure 17. Maximum Avalanche Energy vs Temperature**

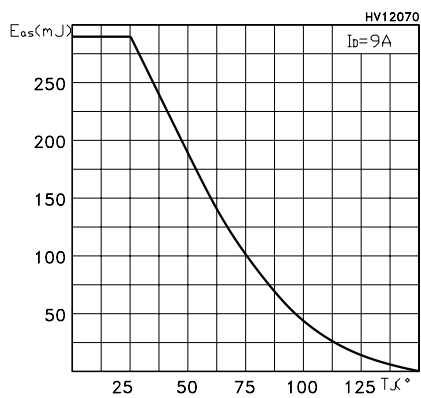

### 3 Test circuits

Figure 18. Switching Times Test Circuit For Resistive Load

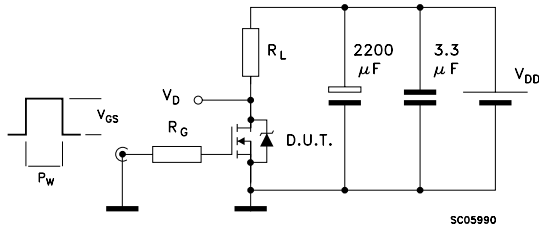

Figure 19. Gate Charge Test Circuit

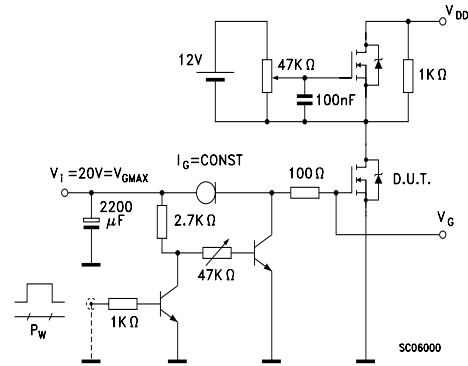
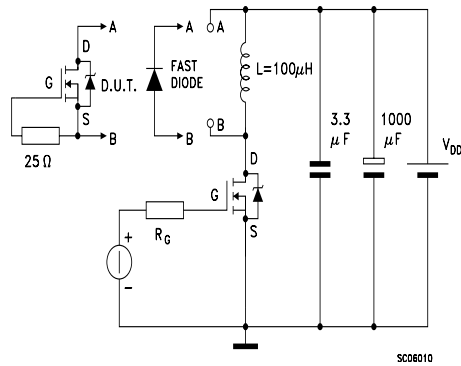

Figure 20. Test Circuit For Inductive Load Switching and Diode Recovery Times





## 4 Package mechanical data

In order to meet environmental requirements, ST offers these devices in ECOPACK® packages. These packages have a Lead-free second level interconnect . The category of second level interconnect is marked on the package and on the inner box label, in compliance with JEDEC Standard JESD97. The maximum ratings related to soldering conditions are also marked on the inner box label. ECOPACK is an ST trademark. ECOPACK specifications are available at: [www.st.com](http://www.st.com)

**TO-220 MECHANICAL DATA**

DIM.	mm.			inch		
	MIN.	TYP.	MAX.	MIN.	TYP.	MAX.
A	4.40		4.60	0.173		0.181
b	0.61		0.88	0.024		0.034
b1	1.15		1.70	0.045		0.066
c	0.49		0.70	0.019		0.027
D	15.25		15.75	0.60		0.620
E	10		10.40	0.393		0.409
e	2.40		2.70	0.094		0.106
e1	4.95		5.15	0.194		0.202
F	1.23		1.32	0.048		0.052
H1	6.20		6.60	0.244		0.256
J1	2.40		2.72	0.094		0.107
L	13		14	0.511		0.551
L1	3.50		3.93	0.137		0.154
L20		16.40			0.645	
L30		28.90			1.137	
øP	3.75		3.85	0.147		0.151
Q	2.65		2.95	0.104		0.116

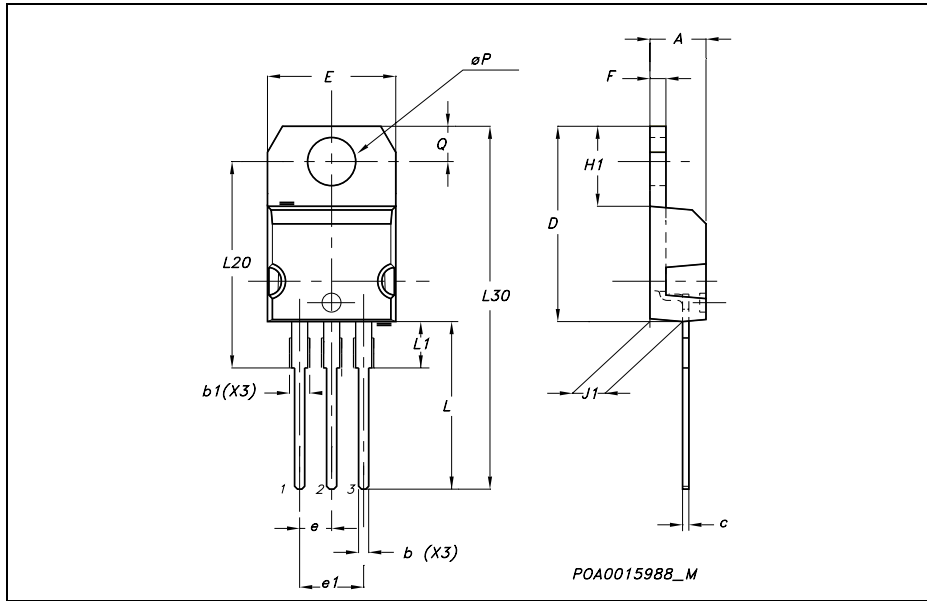

TO-220FP MECHANICAL DATA

DIM.	mm.			inch		
	MIN.	TYP.	MAX.	MIN.	TYP.	MAX.
A	4.4		4.6	0.173		0.181
B	2.5		2.7	0.098		0.106
D	2.5		2.75	0.098		0.108
E	0.45		0.7	0.017		0.027
F	0.75		1	0.030		0.039
F1	1.15		1.7	0.045		0.067
F2	1.15		1.7	0.045		0.067
G	4.95		5.2	0.195		0.204
G1	2.4		2.7	0.094		0.106
H	10		10.4	0.393		0.409
L2		16			0.630	
L3	28.6		30.6	1.126		1.204
L4	9.8		10.6	.0385		0.417
L5	2.9		3.6	0.114		0.141
L6	15.9		16.4	0.626		0.645
L7	9		9.3	0.354		0.366
Ø	3		3.2	0.118		0.126

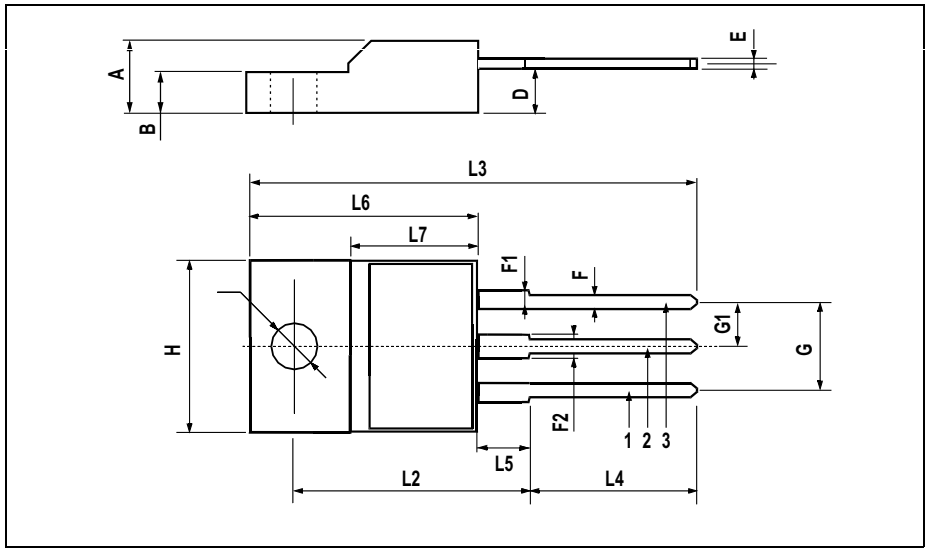

## TO-247 MECHANICAL DATA

DIM.	mm.			inch		
	MIN.	TYP.	MAX.	MIN.	TYP.	MAX.
A	4.85		5.15	0.19		0.20
A1	2.20		2.60	0.086		0.102
b	1.0		1.40	0.039		0.055
b1	2.0		2.40	0.079		0.094
b2	3.0		3.40	0.118		0.134
c	0.40		0.80	0.015		0.03
D	19.85		20.15	0.781		0.793
E	15.45		15.75	0.608		0.620
e		5.45			0.214	
L	14.20		14.80	0.560		0.582
L1	3.70		4.30	0.14		0.17
L2		18.50			0.728	
øP	3.55		3.65	0.140		0.143
øR	4.50		5.50	0.177		0.216
S		5.50			0.216	

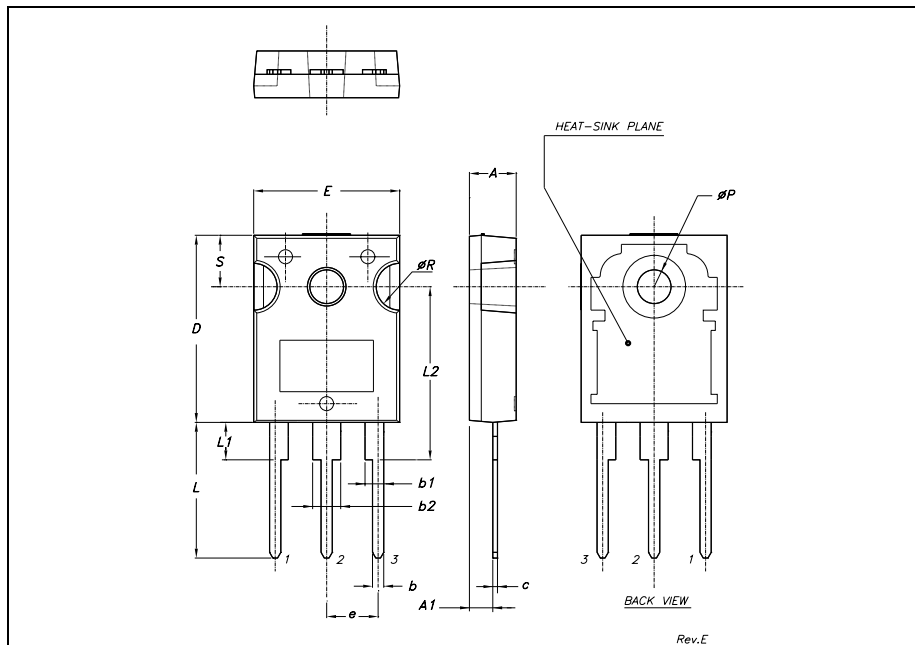

## 5 Revision History

Date	Revision	Changes
30-Aug-2005	2	Inserted new package (D <sup>2</sup> PAK)

Information furnished is believed to be accurate and reliable. However, STMicroelectronics assumes no responsibility for the consequences of use of such information nor for any infringement of patents or other rights of third parties which may result from its use. No license is granted by implication or otherwise under any patent or patent rights of STMicroelectronics. Specifications mentioned in this publication are subject to change without notice. This publication supersedes and replaces all information previously supplied. STMicroelectronics products are not authorized for use as critical components in life support devices or systems without express written approval of STMicroelectronics.

The ST logo is a registered trademark of STMicroelectronics.  
All other names are the property of their respective owners

© 2005 STMicroelectronics - All rights reserved

STMicroelectronics group of companies

Australia - Belgium - Brazil - Canada - China - Czech Republic - Finland - France - Germany - Hong Kong - India - Israel - Italy - Japan -  
Malaysia - Malta - Morocco - Singapore - Spain - Sweden - Switzerland - United Kingdom - United States of America

[www.st.com](http://www.st.com)