

## HIGH SPEED SWITCHES

PRELIMINARY DATA

### DESCRIPTION

The 2N2219A and 2N2222A are silicon Planar Epitaxial NPN transistors in Jedec TO-39 (for 2N2219A) and in Jedec TO-18 (for 2N2222A) metal case. They are designed for high speed switching application at collector current up to 500mA, and feature useful current gain over a wide range of collector current, low leakage currents and low saturation voltage.

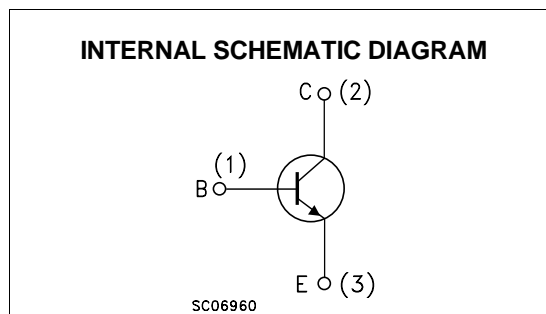
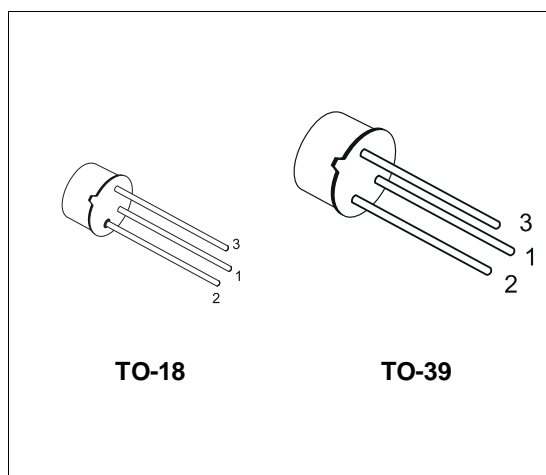

### ABSOLUTE MAXIMUM RATINGS

Symbol	Parameter	Value	Unit
$V_{CBO}$	Collector-Base Voltage ( $I_E = 0$ )	75	V
$V_{CEO}$	Collector-Emitter Voltage ( $I_B = 0$ )	40	V
$V_{EBO}$	Emitter-Base Voltage ( $I_C = 0$ )	6	V
$I_C$	Collector Current	0.6	A
$I_{CM}$	Collector Peak Current ( $t_p < 5$ ms)	0.8	A
$P_{tot}$	Total Dissipation at $T_{amb} \leq 25$ °C for <b>2N2219A</b> for <b>2N2222A</b> at $T_C \leq 25$ °C for <b>2N2219A</b> for <b>2N2222A</b>	0.8	W
		0.5	W
		3	W
		1.8	W
$T_{stg}$	Storage Temperature	-65 to 175	°C
$T_j$	Max. Operating Junction Temperature	175	°C

## 2N2219A / 2N2222A

### THERMAL DATA

		TO-39	TO-18	
R <sub>thj-case</sub>	Thermal Resistance Junction-Case	Max	50	83.3
R <sub>thj-amb</sub>	Thermal Resistance Junction-Ambient	Max	187.5	300
				°C/W
				°C/W

### ELECTRICAL CHARACTERISTICS (T<sub>case</sub> = 25 °C unless otherwise specified)

Symbol	Parameter	Test Conditions	Min.	Typ.	Max.	Unit
I <sub>CBO</sub>	Collector Cut-off Current (I <sub>E</sub> = 0)	V <sub>CB</sub> = 60 V V <sub>CB</sub> = 60 V T <sub>j</sub> = 150 °C			10 10	nA μA
I <sub>CEX</sub>	Collector Cut-off Current (V <sub>BE</sub> = -3V)	V <sub>CE</sub> = 60 V			10	nA
I <sub>BEX</sub>	Base Cut-off Current (V <sub>BE</sub> = -3V)	V <sub>CE</sub> = 60 V			20	nA
I <sub>EBO</sub>	Emitter Cut-off Current (I <sub>C</sub> = 0)	V <sub>EB</sub> = 3 V			10	nA
V <sub>(BR)CBO</sub>	Collector-Base Breakdown Voltage (I <sub>E</sub> = 0)	I <sub>C</sub> = 10 μA	75			V
V <sub>(BR)CEO*</sub>	Collector-Emitter Breakdown Voltage (I <sub>B</sub> = 0)	I <sub>C</sub> = 10 mA	40			V
V <sub>(BR)EBO</sub>	Emitter-Base Breakdown Voltage (I <sub>C</sub> = 0)	I <sub>E</sub> = 10 μA	6			V
V <sub>CE(sat)*</sub>	Collector-Emitter Saturation Voltage	I <sub>C</sub> = 150 mA I <sub>B</sub> = 15 mA I <sub>C</sub> = 500 mA I <sub>B</sub> = 50 mA			0.3 1	V V
V <sub>BE(sat)*</sub>	Base-Emitter Saturation Voltage	I <sub>C</sub> = 150 mA I <sub>B</sub> = 15 mA I <sub>C</sub> = 500 mA I <sub>B</sub> = 50 mA	0.6		1.2 2	V V
h <sub>FE*</sub>	DC Current Gain	I <sub>C</sub> = 0.1 mA V <sub>CE</sub> = 10 V I <sub>C</sub> = 1 mA V <sub>CE</sub> = 10 V I <sub>C</sub> = 10 mA V <sub>CE</sub> = 10 V I <sub>C</sub> = 150 mA V <sub>CE</sub> = 10 V I <sub>C</sub> = 500 mA V <sub>CE</sub> = 10 V I <sub>C</sub> = 150 mA V <sub>CE</sub> = 1 V I <sub>C</sub> = 10 mA V <sub>CE</sub> = 10 V T <sub>amb</sub> = -55 °C	35 50 75 100 40 50 35		300	
h <sub>fe*</sub>	Small Signal Current Gain	I <sub>C</sub> = 1 mA V <sub>CE</sub> = 10 V f = 1KHZ I <sub>C</sub> = 10 mA V <sub>CE</sub> = 10 V f = 1KHZ	50 75		300 375	
f <sub>T</sub>	Transition Frequency	I <sub>C</sub> = 20 mA V <sub>CE</sub> = 20 V f = 100 MHz		300		MHz
C <sub>EBO</sub>	Emitter-Base Capacitance	I <sub>C</sub> = 0 V <sub>EB</sub> = 0.5 V f = 100KHz			25	pF
C <sub>CBO</sub>	Collector-Base Capacitance	I <sub>E</sub> = 0 V <sub>CB</sub> = 10 V f = 100 KHz			8	pF
R <sub>e(hie)</sub>	Real Part of Input Impedance	I <sub>C</sub> = 20 mA V <sub>CE</sub> = 20 V f = 300MHz			60	Ω

\* Pulsed: Pulse duration = 300 μs, duty cycle ≤ 1 %

**ELECTRICAL CHARACTERISTICS** (continued)

Symbol	Parameter	Test Conditions	Min.	Typ.	Max.	Unit
NF	Noise Figure	$I_C = 0.1 \text{ mA}$ $V_{CE} = 10 \text{ V}$ $f = 1 \text{ KHz}$ $R_g = 1 \text{ K}\Omega$		4		dB
$h_{ie}$	Input Impedance	$I_C = 1 \text{ mA}$ $V_{CE} = 10 \text{ V}$ $I_C = 10 \text{ mA}$ $V_{CE} = 10 \text{ V}$	2 0.25		8 1.25	$\text{k}\Omega$ $\text{k}\Omega$
$h_{re}$	Reverse Voltage Ratio	$I_C = 1 \text{ mA}$ $V_{CE} = 10 \text{ V}$ $I_C = 10 \text{ mA}$ $V_{CE} = 10 \text{ V}$			8 4	$10^{-4}$ $10^{-4}$
$h_{oe}$	Output Admittance	$I_C = 1 \text{ mA}$ $V_{CE} = 10 \text{ V}$ $I_C = 10 \text{ mA}$ $V_{CE} = 10 \text{ V}$	5 25		35 200	$\mu\text{S}$ $\mu\text{S}$
$t_d^{**}$	Delay Time	$V_{CC} = 30 \text{ V}$ $I_C = 150 \text{ mA}$ $I_{B1} = 15 \text{ mA}$ $V_{BB} = -0.5 \text{ V}$			10	ns
$t_r^{**}$	Rise Time	$V_{CC} = 30 \text{ V}$ $I_C = 150 \text{ mA}$ $I_{B1} = 15 \text{ mA}$ $V_{BB} = -0.5 \text{ V}$			25	ns
$t_s^{**}$	Storage Time	$V_{CC} = 30 \text{ V}$ $I_C = 150 \text{ mA}$ $I_{B1} = -I_{B2} = 15 \text{ mA}$			225	ns
$t_f^{**}$	Fall Time	$V_{CC} = 30 \text{ V}$ $I_C = 150 \text{ mA}$ $I_{B1} = -I_{B2} = 15 \text{ mA}$			60	ns
$r_{bb}$ , $C_{b'c}$	Feedback Time Constant	$I_C = 20 \text{ mA}$ $V_{CE} = 20 \text{ V}$ $f = 31.8 \text{ MHz}$			150	ps

\* Pulsed: Pulse duration = 300  $\mu\text{s}$ , duty cycle  $\leq 1\%$ 

\*\* See test circuit

**TO-39 MECHANICAL DATA**

DIM.	mm			inch		
	MIN.	TYP.	MAX.	MIN.	TYP.	MAX.
A	12.7			0.500		
B			0.49			0.019
D			6.6			0.260
E			8.5			0.334
F			9.4			0.370
G	5.08			0.200		
H			1.2			0.047
I			0.9			0.035
L	45° (typ.)					

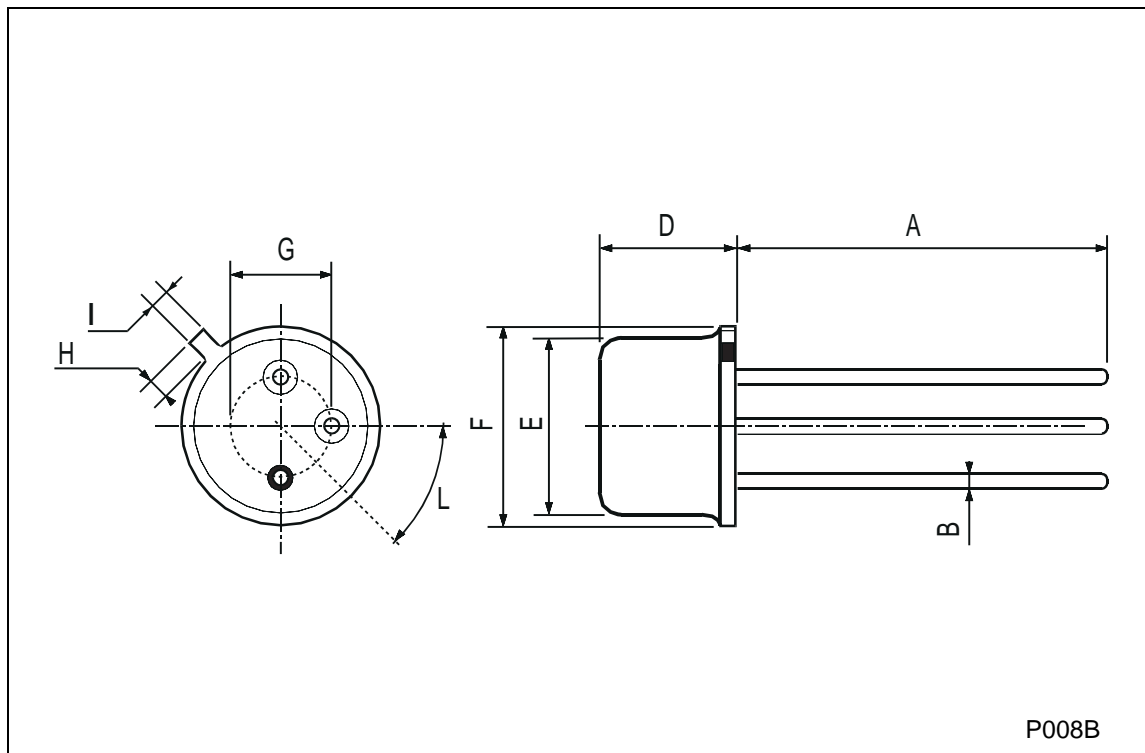

P008B