

## Complementary power transistors

### Features

- Complementary PNP-NPN devices
- New enhanced series
- High switching speed
- $h_{FE}$  grouping
- $h_{FE}$  improved linearity

### Applications

- General purpose circuits
- Audio amplifier
- Power linear and switching

### Description

The TIP41C is a base island technology NPN power transistor in TO-220 plastic package that make this device suitable for audio, power linear and switching applications. The complementary PNP type is TIP42C

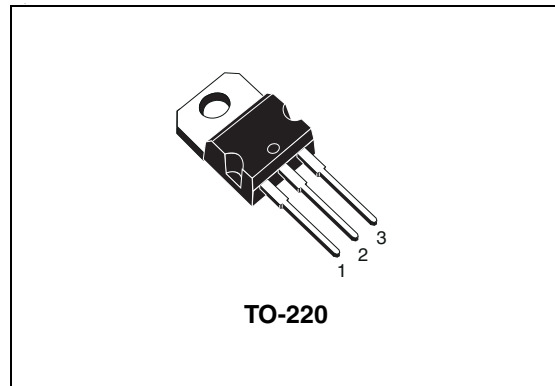

**Figure 1. Internal schematic diagram**

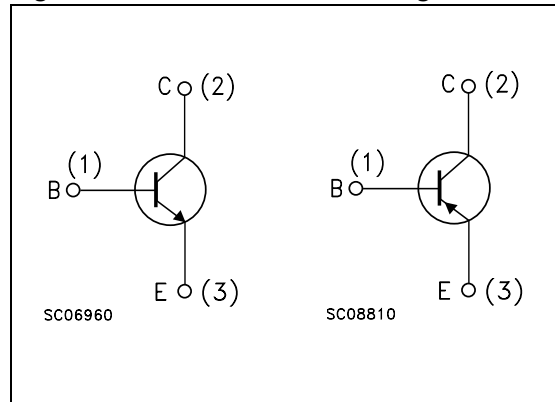

**Table 1. Device summary**

Order code	Marking	Package	Packaging
TIP41C ( <i>Note 1 on page 4</i> )	TIP41C R TIP41C O TIP41C Y	TO-220	Tube
TIP42C ( <i>Note 1 on page 4</i> )	TIP42C R TIP42C O TIP42C Y	TO-220	Tube

# 1 Absolute maximum ratings

**Table 2. Absolute maximum ratings**

Symbol	Parameter	Value	Unit
$V_{CBO}$	Collector-base voltage ( $I_E = 0$ )	100	V
$V_{CEO}$	Collector-emitter voltage ( $I_B = 0$ )	100	V
$V_{EBO}$	Emitte-base voltage ( $I_C = 0$ )	5	V
$I_C$	Collector current	6	A
$I_{CM}$	Collector peak current ( $t_P < 5ms$ )	10	A
$I_B$	Base current	3	A
$P_{TOT}$	Total dissipation at $T_{case} = 25^\circ C$	65	W
$T_{stg}$	Storage temperature	-65 to 150	$^\circ C$
$T_J$	Max. operating junction temperature	150	$^\circ C$

*Note:* For PNP types voltage and current values are negative

## 2 Electrical characteristics

( $T_{\text{case}} = 25^{\circ}\text{C}$ ; unless otherwise specified)

**Table 3. Electrical characteristics**

Symbol	Parameter	Test conditions	Min.	Typ.	Max.	Unit
$I_{\text{CEO}}$	Collector cut-off current ( $I_{\text{B}} = 0$ )	$V_{\text{CE}} = 60 \text{ V}$			0.7	mA
$I_{\text{EBO}}$	Emitter cut-off current ( $I_{\text{C}} = 0$ )	$V_{\text{EB}} = 5 \text{ V}$			1	mA
$I_{\text{CES}}$	Collector cut-off current ( $V_{\text{BE}} = 0$ )	$V_{\text{CE}} = 100 \text{ V}$			0.4	mA
$V_{\text{CEO(sus)}}^{(1)}$	Collector-emitter sustaining voltage ( $I_{\text{B}} = 0$ )	$I_{\text{C}} = 30 \text{ mA}$	100			V
$V_{\text{CE(sat)}}^{(1)}$	Collector-emitter saturation voltage	$I_{\text{C}} = 6 \text{ A}$ $I_{\text{B}} = 0.6 \text{ A}$			1.5	V
$V_{\text{BE(on)}}^{(1)}$	Base-emitter voltage	$I_{\text{C}} = 6 \text{ A}$ $V_{\text{CE}} = 4 \text{ V}$			2	V
$h_{\text{FE}}^{(1)}$	DC current gain	$I_{\text{C}} = 0.3 \text{ A}$ $V_{\text{CE}} = 4 \text{ V}$ $I_{\text{C}} = 3 \text{ A}$ $V_{\text{CE}} = 4 \text{ V}$ Group R Group O Group Y	30 15 15 24 42		75 28 44 75	

1. Pulsed duration = 300 ms, duty cycle  $\geq 1.5\%$ .

**Note:** 1 *Product is pre-selected in DC current gain (group R, group O and group Y). STMicroelectronics reserves the right to ship either groups according to production availability. Please contact your nearest STMicroelectronics sales office for delivery details.*

**Note:** *For PNP types voltage e current values are negative.*

### 3 Package mechanical data

In order to meet environmental requirements, ST offers these devices in ECOPACK® packages. These packages have a Lead-free second level interconnect . The category of second level interconnect is marked on the package and on the inner box label, in compliance with JEDEC Standard JESD97. The maximum ratings related to soldering conditions are also marked on the inner box label. ECOPACK is an ST trademark.

TO-220 mechanical data

Dim	mm			inch		
	Min	Typ	Max	Min	Typ	Max
A	4.40		4.60	0.173		0.181
b	0.61		0.88	0.024		0.034
b1	1.14		1.70	0.044		0.066
c	0.49		0.70	0.019		0.027
D	15.25		15.75	0.6		0.62
D1		1.27			0.050	
E	10		10.40	0.393		0.409
e	2.40		2.70	0.094		0.106
e1	4.95		5.15	0.194		0.202
F	1.23		1.32	0.048		0.051
H1	6.20		6.60	0.244		0.256
J1	2.40		2.72	0.094		0.107
L	13		14	0.511		0.551
L1	3.50		3.93	0.137		0.154
L20		16.40			0.645	
L30		28.90			1.137	
ØP	3.75		3.85	0.147		0.151
Q	2.65		2.95	0.104		0.116

