



# LM139,A LM239,A - LM339,A

## LOW POWER QUAD VOLTAGE COMPARATORS

- WIDE SINGLE SUPPLY VOLTAGE RANGE OR DUAL SUPPLIES FOR ALL DEVICES : +2V TO +36V OR ±1V TO ±18V
- VERY LOW SUPPLY CURRENT (1.1mA) INDEPENDENT OF SUPPLY VOLTAGE (1.4mW/comparator at +5V)
- LOW INPUT BIAS CURRENT : 25nA TYP
- LOW INPUT OFFSET CURRENT : ±5nA TYP
- LOW INPUT OFFSET VOLTAGE : ±1mV TYP
- INPUT COMMON-MODE VOLTAGE RANGE INCLUDES GROUND
- LOW OUTPUT SATURATION VOLTAGE : 250mV TYP; (I<sub>o</sub> = 4mA)
- DIFFERENTIAL INPUT VOLTAGE RANGE EQUAL TO THE SUPPLY VOLTAGE
- TTL, DTL, ECL, MOS, CMOS COMPATIBLE OUTPUTS

### DESCRIPTION

These devices consist of four independent precision voltage comparators with an offset voltage specifications as low as 2mV max for LM339A, LM239A and LM139A. All these comparators were designed specifically to operate from a single power supply over a wide range of voltages. Operation from split power supplies is also possible.

These comparators also have a unique characteristic in that the input common-mode voltage range includes ground even though operated from a single power supply voltage.

### PIN CONNECTIONS (top view)

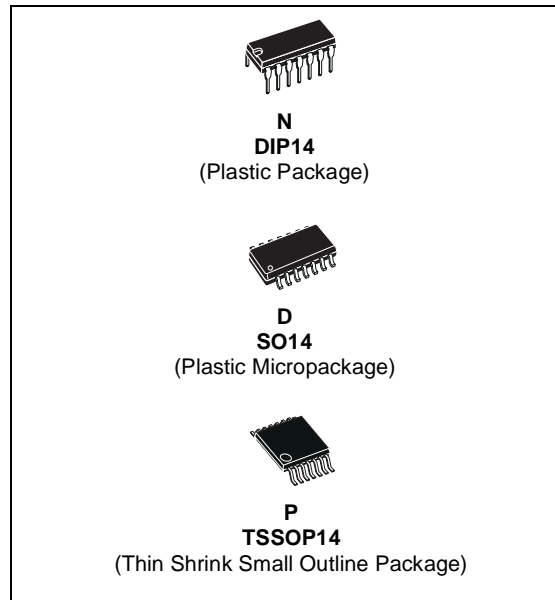
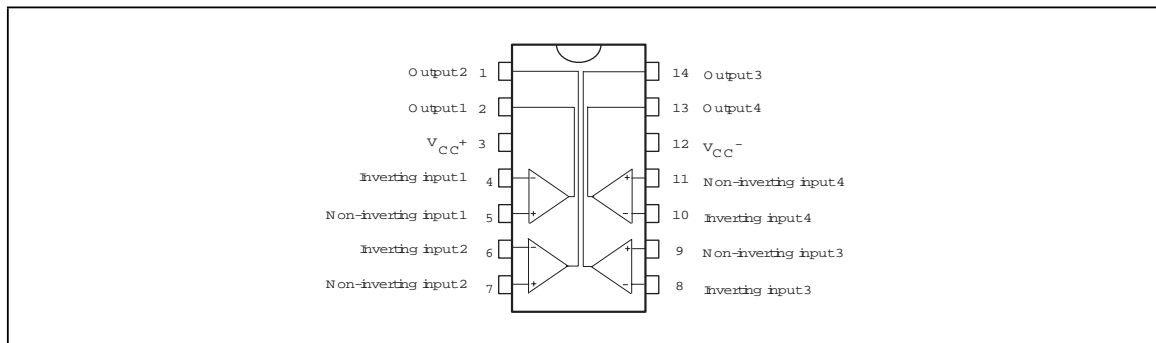

### ORDER CODE

Part Number	Temperature Range	Package		
		N	D	P
LM139,A	-55°C, +125°C	•	•	•
LM239,A	-40°C, +105°C	•	•	•
LM339,A	0°C, +70°C	•	•	•

Example : LM139AN

N = Dual in Line Package (DIP)  
D = Small Outline Package (SO) - also available in Tape & Reel (DT)  
P = Thin Shrink Small Outline Package (TSSOP) - only available in Tape & Reel (PT)

**SCHEMATIC DIAGRAM (1/4 LM139)**

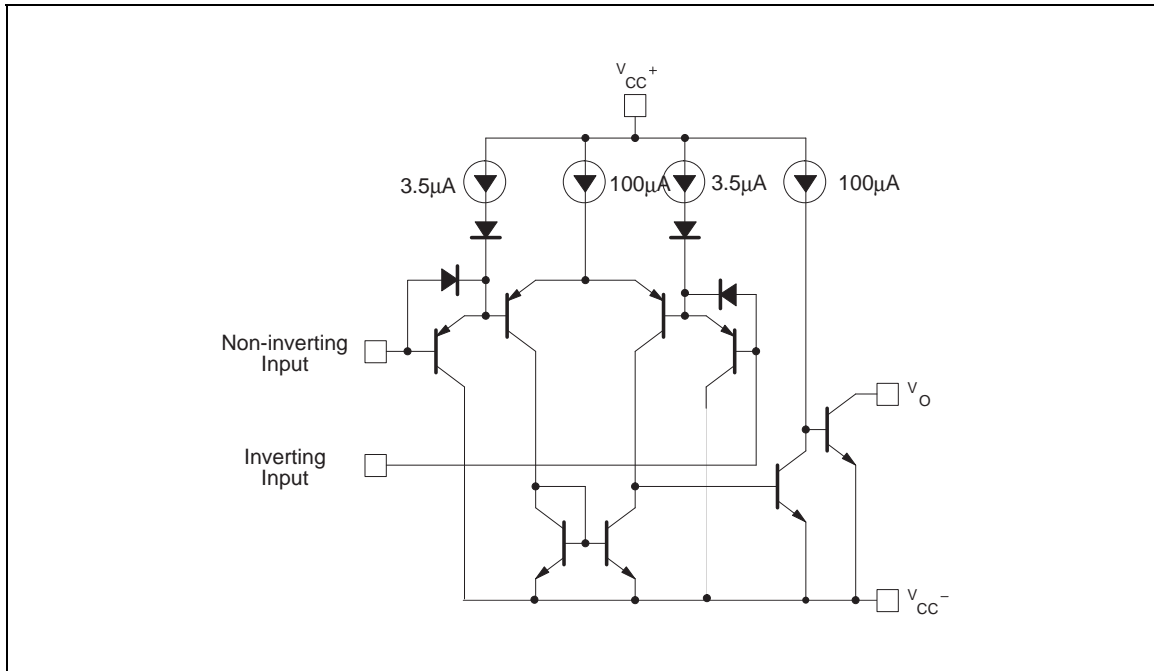

**ABSOLUTE MAXIMUM RATINGS**

Symbol	Parameter	Value	Unit	
$V_{CC}$	Supply voltage	$\pm 18$ or 36	V	
$V_{id}$	Differential Input Voltage	$\pm 36$	V	
$V_i$	Input Voltage	-0.3 to +36	V	
	Output Short-circuit to Ground - note 1)	Infinite		
$P_d$	Power Dissipation 2)	DIP14 SO14 TSSOP14	1500 830 710	mW
$T_{stg}$	Storage Temperature Range	-65 to +150	°C	
$T_j$	Junction Temperature	+150	°C	

1. Short-circuits from the output to  $V_{CC}^+$  can cause excessive heating and eventual destruction. The maximum output current is approximately 20mA independent of the magnitude of  $V_{CC}^+$ .

2.  $P_d$  is calculated with  $T_{amb} = +25^\circ\text{C}$ ,  $T_j = +150^\circ\text{C}$  and  $R_{thja} = 80^\circ\text{C/W}$  for DIP14 package  
 $= 150^\circ\text{C/W}$  for SO14 package  
 $= 175^\circ\text{C/W}$  for TSSOP14 package

**OPERATING CONDITIONS ( $T_{amb} = 25^\circ\text{C}$ )**

Symbol	Parameter	Value	Unit	
$V_{CC}$	Supply Voltage	2 to 32 $\pm 1$ to $\pm 16$	V	
$V_{icm}$	Common Mode Input Voltage Range	0 to $(V_{CC}^+ - 1.5)$	V	
$T_{oper}$	Operating Free-air Temperature Range	LM139, LM139A LM239, LM239A LM339, LM339A	-55, +125 -40, +105 0, +70	°C

**ELECTRICAL CHARACTERISTICS**

$V_{CC}^+ = +5V$ ,  $V_{CC}^- = GND$ ,  $T_{amb} = +25^\circ C$  (unless otherwise specified)

Symbol	Parameter	LM139A - LM239A LM339A			LM139- LM239 LM339			Unit
		Min.	Typ.	Max.	Min	Typ.	Max.	
$V_{io}$	Input Offset Voltage - note <sup>1)</sup> $T_{amb} = +25^\circ C$ $T_{min} \leq T_{amb} \leq T_{max}$		1	2 4		1	5 9	mV
$I_{io}$	Input Offset Current $T_{amb} = +25^\circ C$ $T_{min} \leq T_{amb} \leq T_{max}$		3	25 100		5	50 150	nA
$I_{ib}$	Input Bias Current ( $I^+$ or $I^-$ ) - note <sup>2)</sup> $T_{amb} = +25^\circ C$ $T_{min} \leq T_{amb} \leq T_{max}$		25	100 300		25	250 400	nA
$A_{vd}$	Large Signal Voltage Gain $V_{CC} = 15V$ , $R_L = 15k\Omega$ , $V_o = 1V$ to $11V$	50	200		50	200		V/mV
$I_{CC}$	Supply Current (all comparators) $V_{CC} = +5V$ , no load $V_{CC} = +30V$ , no load		1.1 1.3	2 2.5		1.1 1.3	2 2.5	mA
$V_{icm}$	Input Common Mode Voltage Range - note <sup>3)</sup> $V_{CC} = 30V$ $T_{amb} = +25^\circ C$ $T_{min} \leq T_{amb} \leq T_{max}$	0 0		$V_{CC}^+ - 1.5$ $V_{CC}^+ - 2$	0 0		$V_{CC}^+ - 1.5$ $V_{CC}^+ - 2$	V
$V_{id}$	Differential Input Voltage -note <sup>4)</sup>			$V_{CC}^+$			$V_{CC}^+$	V
$V_{OL}$	Low Level Output Voltage $V_{id} = -1V$ , $I_{sink} = 4mA$ $T_{amb} = +25^\circ C$ $T_{min} \leq T_{amb} \leq T_{max}$		250	400 700		250	400 700	mV
$I_{OH}$	High Level Output Current ( $V_{id} = 1V$ ) $V_{CC} = V_o = 30V$ $T_{amb} = +25^\circ C$ $T_{min} \leq T_{amb} \leq T_{max}$		0.1	1		0.1	1	nA $\mu A$
$I_{sink}$	Output Sink Current $V_{id} = 1V$ , $V_o = 1.5V$	6	16		6	16		mA
$t_{re}$	Response Time - note <sup>5)</sup> $R_L = 5.1k\Omega$ connected to $V_{CC}^+$		1.3			1.3		$\mu s$
$t_{rel}$	Large Signal Response Time $R_L = 5.1k\Omega$ connected to $V_{CC}^+$ , $e_1 = TTL$ , $V_{(ref)} = +1.4v$		300			300		ns

- At output switch point,  $V_o \approx 1.4V$ ,  $R_s = 0$  with  $V_{CC}^+$  from 5V to 30V, and over the full common-mode range (0V to  $V_{CC}^+ - 1.5V$ ).
- The direction of the input current is out of the IC due to the PNP input stage. This current is essentially constant, independent of the state of the output, so no loading charge exists on the reference of input lines.
- The input common-mode voltage of either input signal voltage should not be allowed to go negative by more than 0.3V. The upper end of the common-mode voltage range is  $V_{CC}^+ - 1.5V$ , but either or both inputs can go to +30V without damage
- The response time specified is for a 100mV input step with 5mV overdrive. For larger overdrive signals 300ns can be obtained
- Positive excursions of input voltage may exceed the power supply level. As long as the other voltage remains within the common-mode range, the comparator will provide a proper output state. The low input voltage state must not be less than -0.3V (or 0.3V below the negative power supply, if used).

**PACKAGE MECHANICAL DATA**  
14 PINS - PLASTIC MICROPACKAGE (SO)

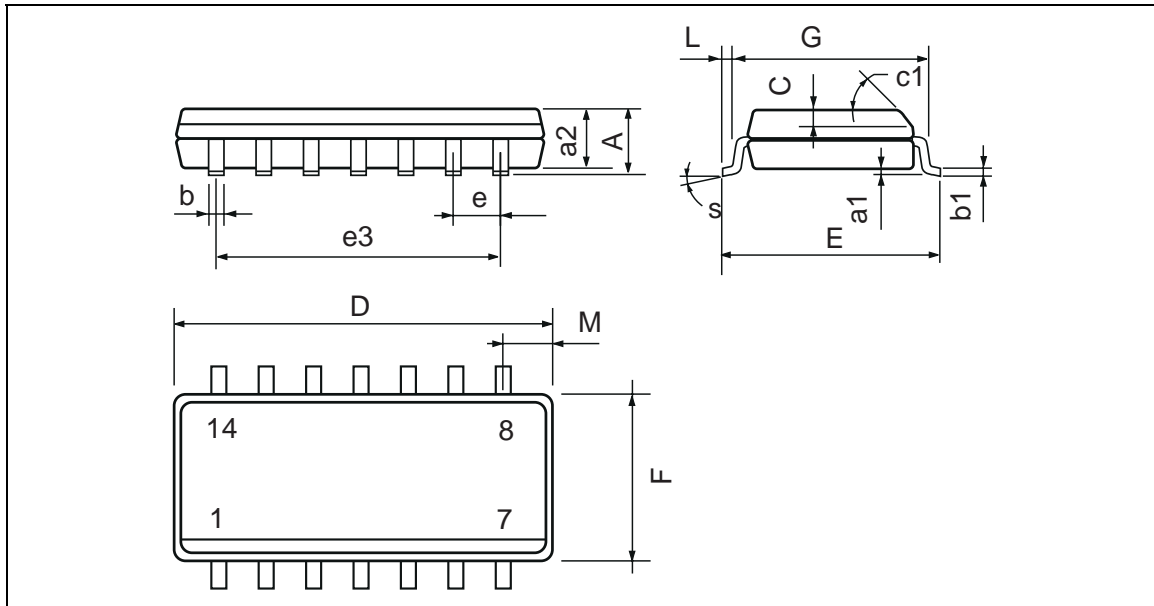

Dimensions	Millimeters			Inches		
	Min.	Typ.	Max.	Min.	Typ.	Max.
A			1.75			0.069
a1	0.1		0.2	0.004		0.008
a2			1.6			0.063
b	0.35		0.46	0.014		0.018
b1	0.19		0.25	0.007		0.010
C		0.5			0.020	
c1	45° (typ.)					
D (1)	8.55		8.75	0.336		0.344
E	5.8		6.2	0.228		0.244
e		1.27			0.050	
e3		7.62			0.300	
F (1)	3.8		4.0	0.150		0.157
G	4.6		5.3	0.181		0.208
L	0.5		1.27	0.020		0.050
M			0.68			0.027
S	8° (max.)					

Note : (1) D and F do not include mold flash or protrusions - Mold flash or protrusions shall not exceed 0.15mm (.066 inc) ONLY FOR DATA BOOK.