

BGA628L7

Silicon Germanium Wide Band Low Noise Amplifier

Data Sheet

Revision 1.1, 2009-12-17
Preliminary

RF & Protection Devices

Edition 2009-12-17

**Published by
Infineon Technologies AG
81726 Munich, Germany**

**© 2009 Infineon Technologies AG
All Rights Reserved.**

Legal Disclaimer

The information given in this document shall in no event be regarded as a guarantee of conditions or characteristics. With respect to any examples or hints given herein, any typical values stated herein and/or any information regarding the application of the device, Infineon Technologies hereby disclaims any and all warranties and liabilities of any kind, including without limitation, warranties of non-infringement of intellectual property rights of any third party.

Information

For further information on technology, delivery terms and conditions and prices, please contact the nearest Infineon Technologies Office (www.infineon.com).

Warnings

Due to technical requirements, components may contain dangerous substances. For information on the types in question, please contact the nearest Infineon Technologies Office.

Infineon Technologies components may be used in life-support devices or systems only with the express written approval of Infineon Technologies, if a failure of such components can reasonably be expected to cause the failure of that life-support device or system or to affect the safety or effectiveness of that device or system. Life support devices or systems are intended to be implanted in the human body or to support and/or maintain and sustain and/or protect human life. If they fail, it is reasonable to assume that the health of the user or other persons may be endangered.

BGA628L7 Silicon Germanium Wide Band Low Noise Amplifier
Revision History: 2009-12-17, Revision 1.1
Previous Revision: 2009-08-03, Revision 1.0

Page	Subjects (major changes since last revision)
5	Features and description updated
6	Table "Pin Definition and Function" added
13	Application Information added

Trademarks of Infineon Technologies AG

A-GOLD™, BlueMoon™, COMNEON™, CONVERGATE™, COSIC™, C166™, CROSSAVE™, CanPAK™, CIPOS™, CoolMOS™, CoolSET™, CONVERPATH™, CORECONTROL™, DAVE™, DUALFALC™, DUSLIC™, EasyPIM™, EconoBRIDGE™, EconoDUAL™, EconoPACK™, EconoPIM™, E-GOLD™, EiceDRIVER™, EUPEC™, ELIC™, EPIC™, FALC™, FCOS™, FLEXISLIC™, GEMINAX™, GOLDMOS™, HITFET™, HybridPACK™, INCA™, ISAC™, ISOFACE™, IsoPACK™, IWORX™, M-GOLD™, MIPAQ™, ModSTACK™, MUSLIC™, my-d™, NovalithIC™, OCTALFALC™, OCTAT™, OmniTune™, OmniVia™, OptiMOS™, OPTIVERSE™, ORIGA™, PROFET™, PRO-SIL™, PrimePACK™, QUADFALC™, RASIC™, ReverSave™, SatRIC™, SCEPTRE™, SCOUT™, S-GOLD™, SensoNor™, SEROCCO™, SICOFI™, SIEGET™, SINDRION™, SLIC™, SMARTi™, SmartLEWIS™, SMINT™, SOCRATES™, TEMPFET™, thinQ!™, TrueENTRY™, TriCore™, TRENCHSTOP™, VINAX™, VINETIC™, VIONTIC™, WildPass™, X-GOLD™, XMM™, X-PMU™, XPOSYS™, XWAY™.

Other Trademarks

AMBA™, ARM™, MULTI-ICE™, PRIMECELL™, REALVIEW™, THUMB™ of ARM Limited, UK. AUTOSAR™ is licensed by AUTOSAR development partnership. Bluetooth™ of Bluetooth SIG Inc. CAT-iq™ of DECT Forum. COLOSSUS™, FirstGPS™ of Trimble Navigation Ltd. EMV™ of EMVCo, LLC (Visa Holdings Inc.). EPCOS™ of Epcos AG. FLEXGO™ of Microsoft Corporation. FlexRay™ is licensed by FlexRay Consortium. HYPERTERMINAL™ of Hilgraeve Incorporated. IEC™ of Commission Electrotechnique Internationale. IrDA™ of Infrared Data Association Corporation. ISO™ of INTERNATIONAL ORGANIZATION FOR STANDARDIZATION. MATLAB™ of MathWorks, Inc. MAXIM™ of Maxim Integrated Products, Inc. MICROTEC™, NUCLEUS™ of Mentor Graphics Corporation. Mifare™ of NXP. MIPI™ of MIPI Alliance, Inc. MIPS™ of MIPS Technologies, Inc., USA. muRata™ of MURATA MANUFACTURING CO. OmniVision™ of OmniVision Technologies, Inc. Openwave™ Openwave Systems Inc. RED HAT™ Red Hat, Inc. RFMD™ RF Micro Devices, Inc. SIRIUS™ of Sirius Sattelite Radio Inc. SOLARIS™ of Sun Microsystems, Inc. SPANSION™ of Spansion LLC Ltd. Symbian™ of Symbian Software Limited. TAIYO YUDEN™ of Taiyo Yuden Co. TEAKLITE™ of CEVA, Inc. TEKTRONIX™ of Tektronix Inc. TOKO™ of TOKO KABUSHIKI KAISHA TA. UNIX™ of X/Open Company Limited. VERILOG™, PALLADIUM™ of Cadence Design Systems, Inc. VLYNQ™ of Texas Instruments Incorporated. VXWORKS™, WIND RIVER™ of WIND RIVER SYSTEMS, INC. ZETEX™ of Diodes Zetex Limited.

Last Trademarks Update 2009-10-19

Table of Contents

	Table of Contents	4
	Features	5
1	Maximum Ratings	7
2	Electrical Characteristics	8
2.1	DC Characteristics	8
2.2	AC Characteristics	9
2.2.1	Electrical Characteristics at $f = 450$ MHz	9
2.2.2	Electrical Characteristics at $f = 900$ MHz	9
2.2.3	Electrical Characteristics at $f = 1.575$ GHz	10
2.2.4	Electrical Characteristics at $f = 1.9$ GHz	10
2.2.5	Electrical Characteristics at $f = 2.14$ GHz	11
2.2.6	Electrical Characteristics at $f = 2.4$ GHz	11
2.2.7	Electrical Characteristics at $f = 3.5$ GHz	12
2.2.8	Electrical Characteristics at $f = 5.5$ GHz	12
3	Application Information	13
4	Package Information	14

Features

- Extremely thin and small dimension (1.4 mm x 1.26 mm x 0.31 mm only)
- Operating frequency range 0.4 - 6 GHz
- High gain at low current consumption of 5.8 mA
 $G_{ma} = 21.5$ dB at 1.575 GHz
 $G_{ma} = 19.0$ dB at 2.4 GHz
- Low noise figure
 $NF_{min} = 0.75$ dB at 1.575 GHz
 $NF_{min} = 0.8$ dB at 2.4 GHz
- Typical supply voltage: 2.75 V
- Off mode
- Integrated RF choke on internal bias network
- Input and Output pre-matched on chip
- Low external part count
- 2 kV HBM ESD protection on all pins
- Leadless, Pb-free (RoHS compliant) and halogen-free TSLP-7-8 package

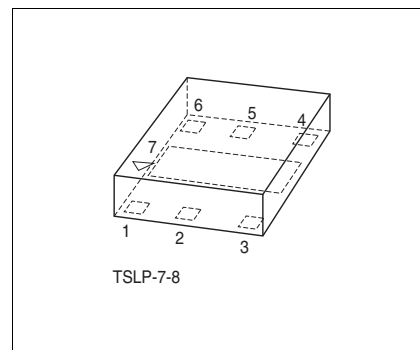

Applications

- General Purpose LNA for Bluetooth, GPS, ISDB-T Mobile TV, UMTS, Wi-Fi and WLAN

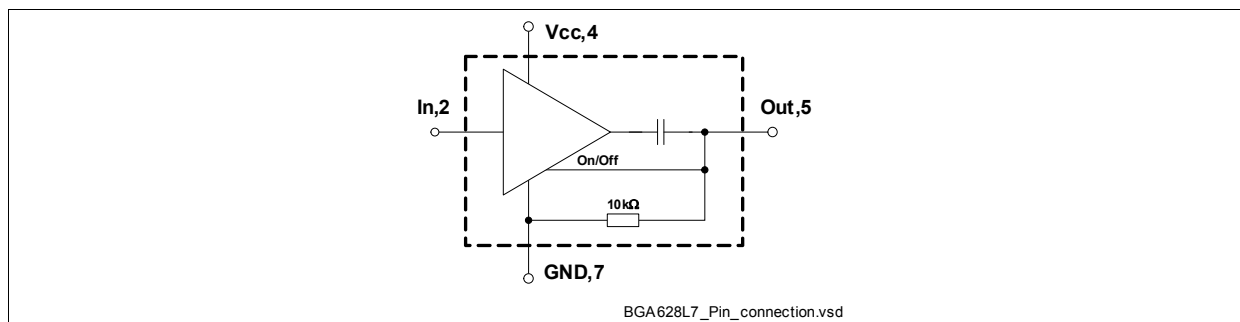

Figure 1 Pin Connection

Note: **ESD**: Electrostatic discharge sensitive device, observe handling precaution

Product Name	Marking	Package
BGA628L7	BR	TSLP-7-8

Description

The BGA628L7 is a wide band low noise amplifier, based on Infineon Technologies' Silicon Germanium Technology B7HFM. It features extremely small form factor with height of 0.32 mm maximum, and size of 1.4 x 1.26 mm² only. Such small dimension, together with the low external part count, has made it ideal for size-critical modules e.g. for WLAN, mobile TV or cellular phones.

Having an On/Off switch on-chip, the LNA's Out pin is simultaneously used for RF Out and On/Off switch. This functionality can be accessed using a RF-Choke at the Out pin, where a DC level of 0 V or an open switches the device on and a DC level of V_{CC} switches off.

Please refer to the product website (www.infineon.com) for various application examples, application notes and technical reports.

Pin Definition and Function

Table 1 Pin Definition and Function

Pin No.	Symbol	Function
1	n.c.	not connected
2	In	RF input
3	n.c.	not connected
4	Vcc	DC supply
5	Out	RF output and On/Off switch
6	n.c.	not connected
7	GND	Ground

1 Maximum Ratings

Table 2 Maximum Ratings

Parameter	Symbol	Values			Unit	Note / Test Condition
		Min.	Typ.	Max.		
Voltage at pin V_{CC}	V_{CC}	–	–	3.5	V	–
Voltage at pin Out	V_{out}	–	–	4	V	–
Current into pin In	I_{in}	–	–	0.1	mA	–
Current into pin Out	I_{out}	–	–	1	mA	–
Current into pin V_{CC}	$I_{V_{CC}}$	–	–	10	mA	–
RF input power	P_{in}	–	–	6	dBm	–
Total power dissipation, $T_S < 138\text{ °C}^{1)}$	P_{tot}	–	–	35	mW	–
Junction temperature	T_J	–	–	150	°C	–
Ambient temperature range	T_A	65	–	150	°C	–
Storage temperature range	T_{STG}	65	–	150	°C	–
ESD capability all pins (HBM: JESD22-A114)	V_{ESD}	–	–	2000	V	–

1) T_S is measured on the ground lead at the soldering point

Note: All Voltages refer to GND-Node

Thermal Resistance

Table 3 Thermal Resistance

Parameter	Symbol	Value	Unit
Junction - soldering point ¹⁾	R_{thJS}	330	K/W

1) For calculation of R_{thJA} please refer to Application Note Thermal Resistance

2 Electrical Characteristics

2.1 DC Characteristics

Table 4 DC Characteristics at $T_A = 25\text{ }^\circ\text{C}$

Parameter	Symbol	Values			Unit	Note / Test Condition
		Min.	Typ.	Max.		
Total device on current	$I_{\text{tot-on}}$	–	5.8	–	mA	$V_{\text{CC}} = 2.75\text{ V}$
Total device off current	$I_{\text{tot-off}}$	–	260	–	μA	$V_{\text{CC}} = 2.75\text{ V}$, $V_{\text{out}} = V_{\text{CC}}$
On / Off switch control voltage	V_{on}	0	–	0.8	V	$V_{\text{CC}} = 2.75\text{ V}$ ON-Mode: $V_{\text{out}} = V_{\text{on}}$
	V_{off}	2.0	–	3.5	V	$V_{\text{CC}} = 2.75\text{ V}$ OFF-Mode: $V_{\text{out}} = V_{\text{off}}$

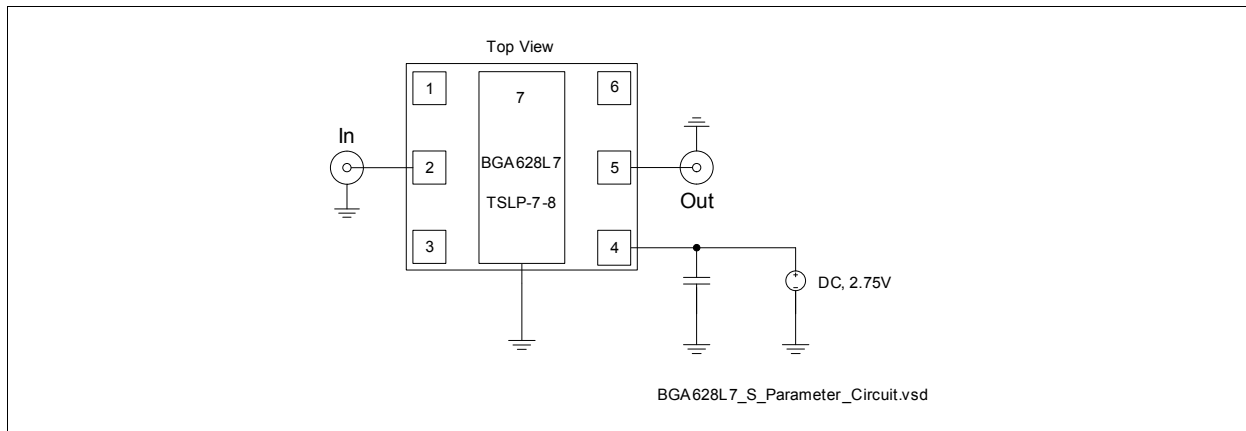

Figure 2 S-Parameter Test Circuit (loss-free microstrip line)

2.2 AC Characteristics

2.2.1 Electrical Characteristics at $f = 450$ MHz

Table 5 Electrical Characteristics at $T_A = 25$ °C (measured according to [Figure 2](#)), $V_{CC} = 2.75$ V, unless otherwise specified

Parameter	Symbol	Values			Unit	Note / Test Condition
		Min.	Typ.	Max.		
Maximum available power gain	G_{ma}	–	24.5	–	dB	–
Insertion power gain	$ S_{21} ^2$	–	18.8	–	dB	–
Insertion power gain (Off-State)	$ S_{21} ^2$	–	-42	–	dB	$V_{out} = 2.75$ V
Input return loss	RL_{in}	–	2	–	dB	–
Output return loss	RL_{out}	–	11	–	dB	–
Minimum noise figure	NF_{min}	–	0.65	–	dB	$Z_S = Z_{Sopt}$
Noise figure in 50 Ω System	$NF_{50\Omega}$	–	0.8	–	dB	$Z_S = Z_L = 50$ Ω
Input third order intercept point ¹⁾ (On-State)	$IIP3$	–	-13	–	dBm	$\Delta f = 1$ MHz, $P_{IN} = -28$ dBm
Input power at 1 dB gain compression	P_{-1dB}	–	-24.5	–	dBm	–

1) IP_3 values depends on termination of all intermodulation frequency components. Termination used for this measurement is 50 Ω from 0.1 to 6 GHz

2.2.2 Electrical Characteristics at $f = 900$ MHz

Table 6 Electrical Characteristics at $T_A = 25$ °C (measured according to [Figure 2](#)), $V_{CC} = 2.75$ V, unless otherwise specified

Parameter	Symbol	Values			Unit	Note / Test Condition
		Min.	Typ.	Max.		
Maximum available power gain	G_{ma}	–	23	–	dB	–
Insertion power gain	$ S_{21} ^2$	–	18.8	–	dB	–
Insertion power gain (Off-State)	$ S_{21} ^2$	–	-34	–	dB	$V_{out} = 2.75$ V
Input return loss	RL_{in}	–	3	–	dB	–
Output return loss	RL_{out}	–	14	–	dB	–
Minimum noise figure	NF_{min}	–	0.7	–	dB	$Z_S = Z_{Sopt}$
Noise figure in 50 Ω System	$NF_{50\Omega}$	–	0.8	–	dB	$Z_S = Z_L = 50$ Ω
Input third order intercept point ¹⁾ (On-State)	$IIP3$	–	-10	–	dBm	$\Delta f = 1$ MHz, $P_{IN} = -28$ dBm
Input power at 1 dB gain compression	P_{-1dB}	–	-24	–	dBm	–

1) IP_3 values depends on termination of all intermodulation frequency components. Termination used for this measurement is 50 Ω from 0.1 to 6 GHz

2.2.3 Electrical Characteristics at $f = 1.575$ GHz

Table 7 Electrical Characteristics at $T_A = 25$ °C (measured according to [Figure 2](#)), $V_{CC} = 2.75$ V, unless otherwise specified

Parameter	Symbol	Values			Unit	Note / Test Condition
		Min.	Typ.	Max.		
Maximum available power gain	G_{ma}	–	21.5	–	dB	–
Insertion power gain	$ S_{21} ^2$	–	18	–	dB	–
Insertion power gain (Off-State)	$ S_{21} ^2$	–	-27	–	dB	$V_{out} = 2.75$ V
Input return loss	RL_{in}	–	4	–	dB	–
Output return loss	RL_{out}	–	11	–	dB	–
Minimum noise figure	NF_{min}	–	0.75	–	dB	$Z_S = Z_{Sopt}$
Noise figure in 50 Ω System	$NF_{50\Omega}$	–	0.85	–	dB	$Z_S = Z_L = 50$ Ω
Input third order intercept point ¹⁾ (On-State)	$IIP3$	–	-2	–	dBm	$\Delta f = 1$ MHz, $P_{IN} = -28$ dBm
Input power at 1 dB gain compression	P_{-1dB}	–	-20.5	–	dBm	–

1) IP_3 values depends on termination of all intermodulation frequency components. Termination used for this measurement is 50 Ω from 0.1 to 6 GHz

2.2.4 Electrical Characteristics at $f = 1.9$ GHz

Table 8 Electrical Characteristics at $T_A = 25$ °C (measured according to [Figure 2](#)), $V_{CC} = 2.75$ V, unless otherwise specified

Parameter	Symbol	Values			Unit	Note / Test Condition
		Min.	Typ.	Max.		
Maximum available power gain	G_{ma}	–	21.0	–	dB	–
Insertion power gain	$ S_{21} ^2$	–	17.5	–	dB	–
Insertion power gain (Off-State)	$ S_{21} ^2$	–	-26	–	dB	$V_{out} = 2.75$ V
Input return loss	RL_{in}	–	5	–	dB	–
Output return loss	RL_{out}	–	10	–	dB	–
Minimum noise figure	NF_{min}	–	0.8	–	dB	$Z_S = Z_{Sopt}$
Noise figure in 50 Ω System	$NF_{50\Omega}$	–	0.9	–	dB	$Z_S = Z_L = 50$ Ω
Input third order intercept point ¹⁾	$IIP3$	–	-1	–	dBm	$\Delta f = 1$ MHz, $P_{IN} = -28$ dBm
Input power at 1 dB gain compression	P_{-1dB}	–	-20	–	dBm	–

1) IP_3 values depends on termination of all intermodulation frequency components. Termination used for this measurement is 50 Ω from 0.1 to 6 GHz

2.2.5 Electrical Characteristics at $f = 2.14$ GHz
Table 9 Electrical Characteristics at $T_A = 25$ °C (measured according to Figure 2), $V_{CC} = 2.75$ V, unless otherwise specified

Parameter	Symbol	Values			Unit	Note / Test Condition
		Min.	Typ.	Max.		
Maximum available power gain	G_{ma}	–	20	–	dB	–
Insertion power gain	$ S_{21} ^2$	–	17	–	dB	–
Insertion power gain (Off-State)	$ S_{21} ^2$	–	-24	–	dB	$V_{out} = 2.75$ V
Input return loss	RL_{in}	–	5	–	dB	–
Output return loss	RL_{out}	–	10	–	dB	–
Minimum noise figure	NF_{min}	–	0.8	–	dB	$Z_S = Z_{Sopt}$
Noise figure in 50 Ω System	$NF_{50\Omega}$	–	0.9	–	dB	$Z_S = Z_L = 50$ Ω
Input third order intercept point ¹⁾ (On-State)	IIP_3	–	0	–	dBm	$\Delta f = 1$ MHz, $P_{IN} = -28$ dBm
Input power at 1 dB gain compression	P_{-1dB}	–	-18.5	–	dBm	–

1) IP_3 values depends on termination of all intermodulation frequency components. Termination used for this measurement is 50 Ω from 0.1 to 6 GHz

2.2.6 Electrical Characteristics at $f = 2.4$ GHz
Table 10 Electrical Characteristics at $T_A = 25$ °C (measured according to Figure 2), $V_{CC} = 2.75$ V, unless otherwise specified

Parameter	Symbol	Values			Unit	Note / Test Condition
		Min.	Typ.	Max.		
Maximum available power gain	G_{ma}	–	19	–	dB	–
Insertion power gain	$ S_{21} ^2$	–	16	–	dB	–
Insertion power gain (Off-State)	$ S_{21} ^2$	–	-24	–	dB	$V_{out} = 2.75$ V
Input return loss	RL_{in}	–	6	–	dB	–
Output return loss	RL_{out}	–	9	–	dB	–
Minimum noise figure	NF_{min}	–	0.8	–	dB	$Z_S = Z_{Sopt}$
Noise figure in 50 Ω System	$NF_{50\Omega}$	–	0.95	–	dB	$Z_S = Z_L = 50$ Ω
Input third order intercept point ¹⁾	IIP_3	–	2	–	dBm	$\Delta f = 1$ MHz, $P_{IN} = -28$ dBm
Input power at 1 dB gain compression	P_{-1dB}	–	-17.5	–	dBm	–

1) IP_3 values depends on termination of all intermodulation frequency components. Termination used for this measurement is 50 Ω from 0.1 to 6 GHz

2.2.7 Electrical Characteristics at $f = 3.5$ GHz
Table 11 Electrical Characteristics at $T_A = 25$ °C (measured according to Figure 2), $V_{CC} = 2.75$ V, unless otherwise specified

Parameter	Symbol	Values			Unit	Note / Test Condition
		Min.	Typ.	Max.		
Maximum available power gain	G_{ma}	–	16	–	dB	–
Insertion power gain	$ S_{21} ^2$	–	13.5	–	dB	–
Insertion power gain (Off-State)	$ S_{21} ^2$	–	-22	–	dB	$V_{out} = 2.75$ V
Input return loss	RL_{in}	–	7	–	dB	–
Output return loss	RL_{out}	–	8	–	dB	–
Minimum noise figure	NF_{min}	–	0.9	–	dB	$Z_S = Z_{Sopt}$
Noise figure in 50 Ω System	$NF_{50\Omega}$	–	1.0	–	dB	$Z_S = Z_L = 50$ Ω
Input third order intercept point ¹⁾	$IIP3$	–	5	–	dBm	$\Delta f = 1$ MHz, $P_{IN} = -28$ dBm
Input power at 1 dB gain compression	P_{-1dB}	–	-14.5	–	dBm	–

1) IP_3 values depends on termination of all intermodulation frequency components. Termination used for this measurement is 50 Ω from 0.1 to 6 GHz

2.2.8 Electrical Characteristics at $f = 5.5$ GHz
Table 12 Electrical Characteristics at $T_A = 25$ °C (measured according to Figure 2), $V_{CC} = 2.75$ V, unless otherwise specified

Parameter	Symbol	Values			Unit	Note / Test Condition
		Min.	Typ.	Max.		
Maximum available power gain	G_{ma}	–	10	–	dB	–
Insertion power gain	$ S_{21} ^2$	–	8	–	dB	–
Insertion power gain (Off-State)	$ S_{21} ^2$	–	-23	–	dB	$V_{out} = 2.75$ V
Input return loss	RL_{in}	–	8	–	dB	–
Output return loss	RL_{out}	–	6	–	dB	–
Minimum noise figure	NF_{min}	–	1.1	–	dB	$Z_S = Z_{Sopt}$
Noise figure in 50 Ω System	$NF_{50\Omega}$	–	1.3	–	dB	$Z_S = Z_L = 50$ Ω
Input third order intercept point ¹⁾	$IIP3$	–	9	–	dBm	$\Delta f = 1$ MHz, $P_{IN} = -28$ dBm
Input power at 1 dB gain compression	P_{-1dB}	–	-11	–	dBm	–

1) IP_3 values depends on termination of all intermodulation frequency components. Termination used for this measurement is 50 Ω from 0.1 to 6 GHz

3 Application Information

A list of all application notes is available at <http://goto.infineon.com/smallsignaldiscretes-appnotes>.

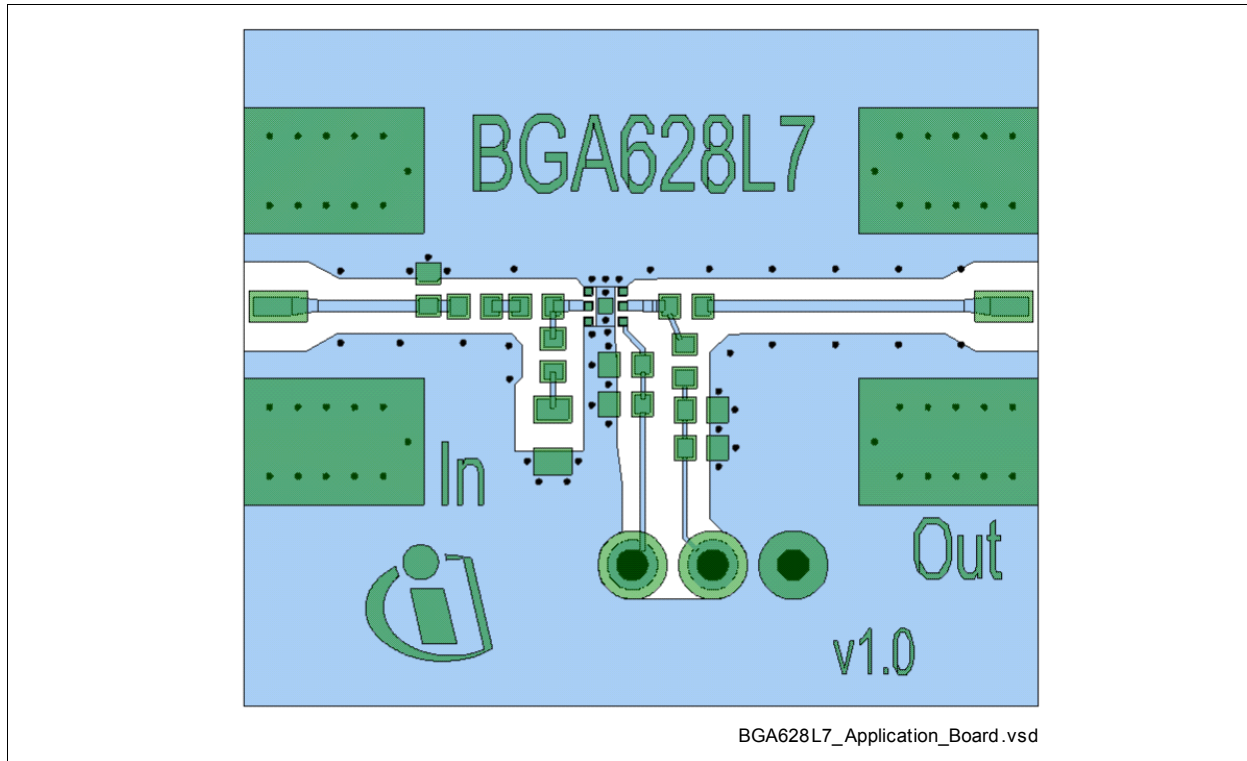

Figure 3 Drawing of Application Board

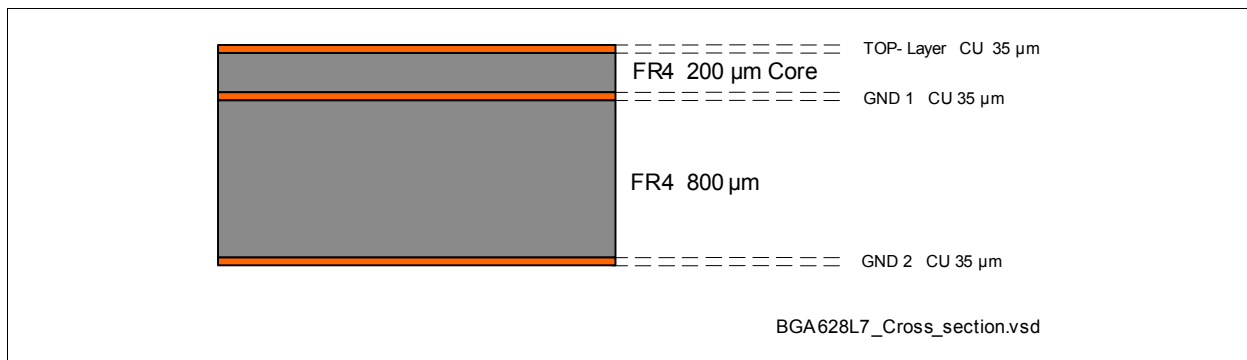

Figure 4 Cross-section of Application Board

4 Package Information

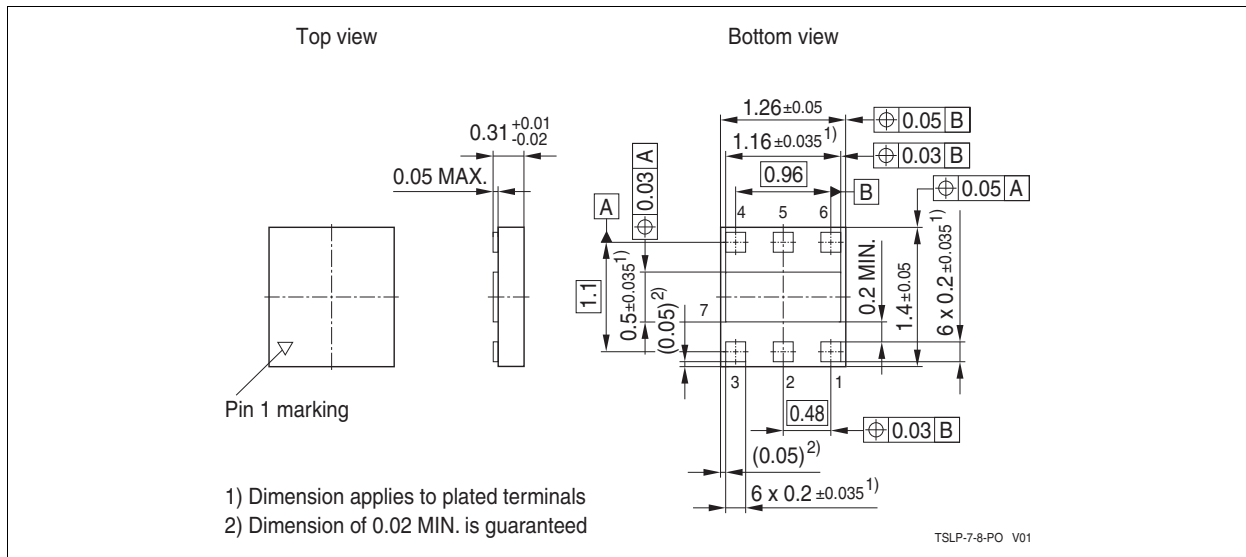

Figure 5 Package Dimensions for TSLP-7-8

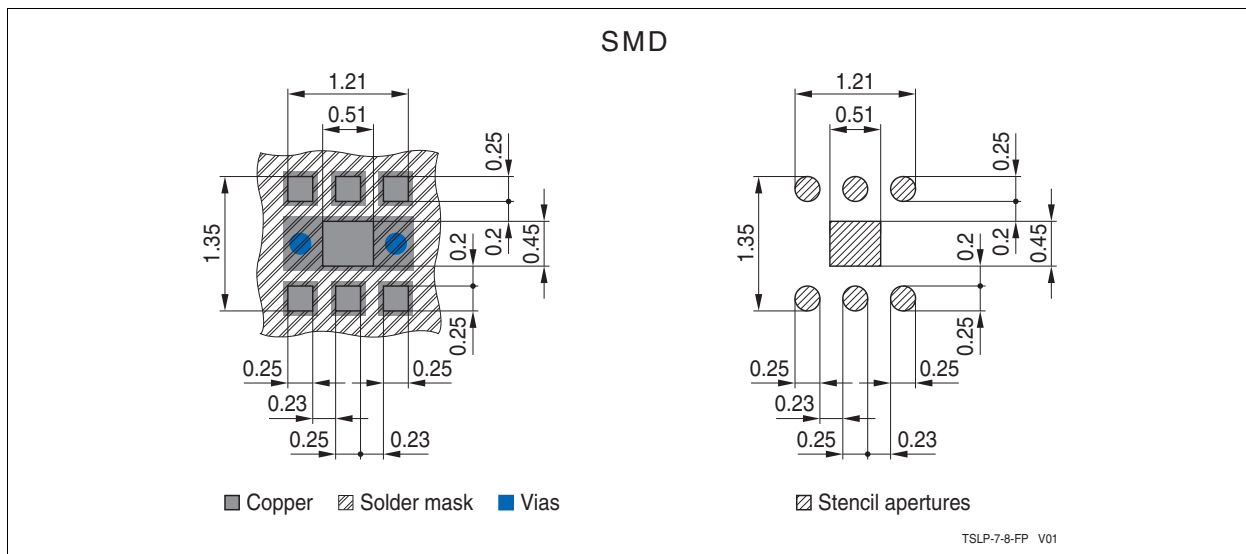

Figure 6 Footprint TSLP-7-8

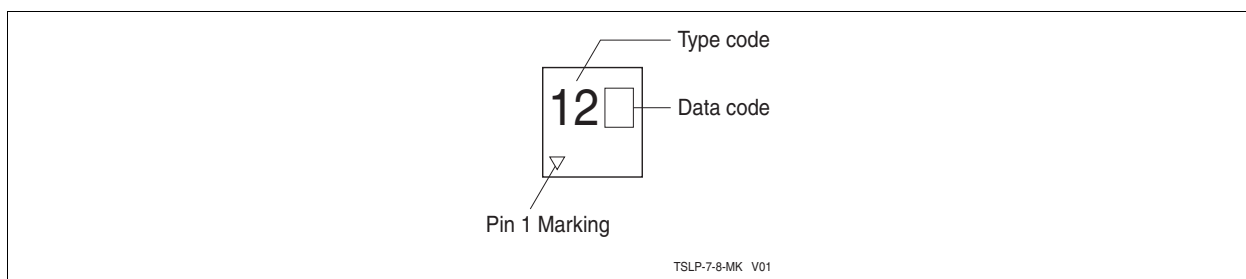

Figure 7 Marking Layout

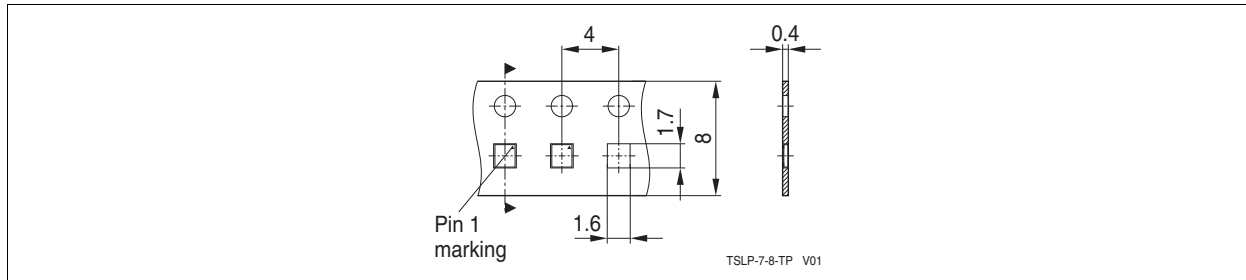

Figure 8 Tape & Reel Dimensions (Ø reel 180 mm, pieces/reel 7500)

www.infineon.com

Published by Infineon Technologies AG