



LM101A-LM201A LM301A

SINGLE OPERATIONAL AMPLIFIERS

	LM101A LM201A	LM301A
■ INPUT OFFSET VOLTAGE	0.7mV	2mV
■ INPUT BIAS CURRENT	25nA	70nA
■ INPUT OFFSET CURRENT	1.5nA	2nA
■ SLEW RATE AS INVERSING AMPLIFIER	10V/μs	10V/μs

DESCRIPTION

The LM101A is a general purpose operational amplifier which offers many features: supply voltages from $\pm 5V$ to $\pm 22V$, low current drain, overload protection on the input and output, no latch-up when the common-mode range is exceeded, free from oscillations and compensation with a single 30pF capacitor. It has advantages over internally compensated amplifiers in that the compensation can be tailored to the particular application: slew rate of 10V/μs and bandwidth of 3.5MHz can be easily achieved.

ORDER CODE

Part Number	Temperature Range	Package	
		N	D
LM101A	-55°C, +125°C	•	•
LM201A	-40°C, +105°C	•	•
LM301A	0°C, +70°C	•	•
Example : LM201AN			

N = Dual in Line Package (DIP)

D = Small Outline Package (SO) - also available in Tape & Reel (DT)

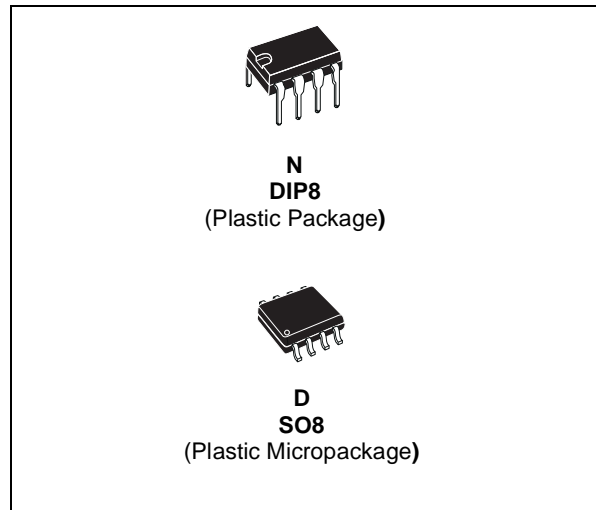

PIN CONNECTIONS (top view)

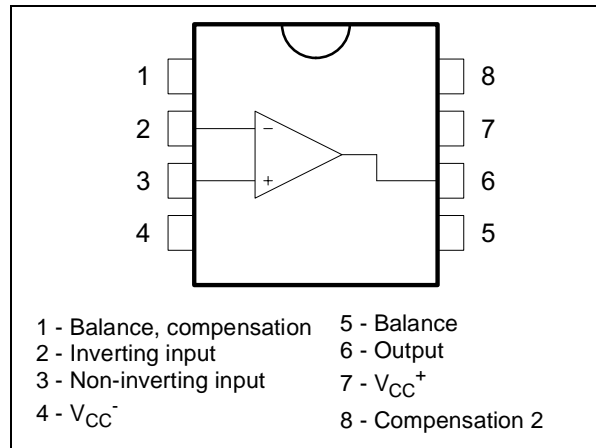

SCHEMATIC DIAGRAM

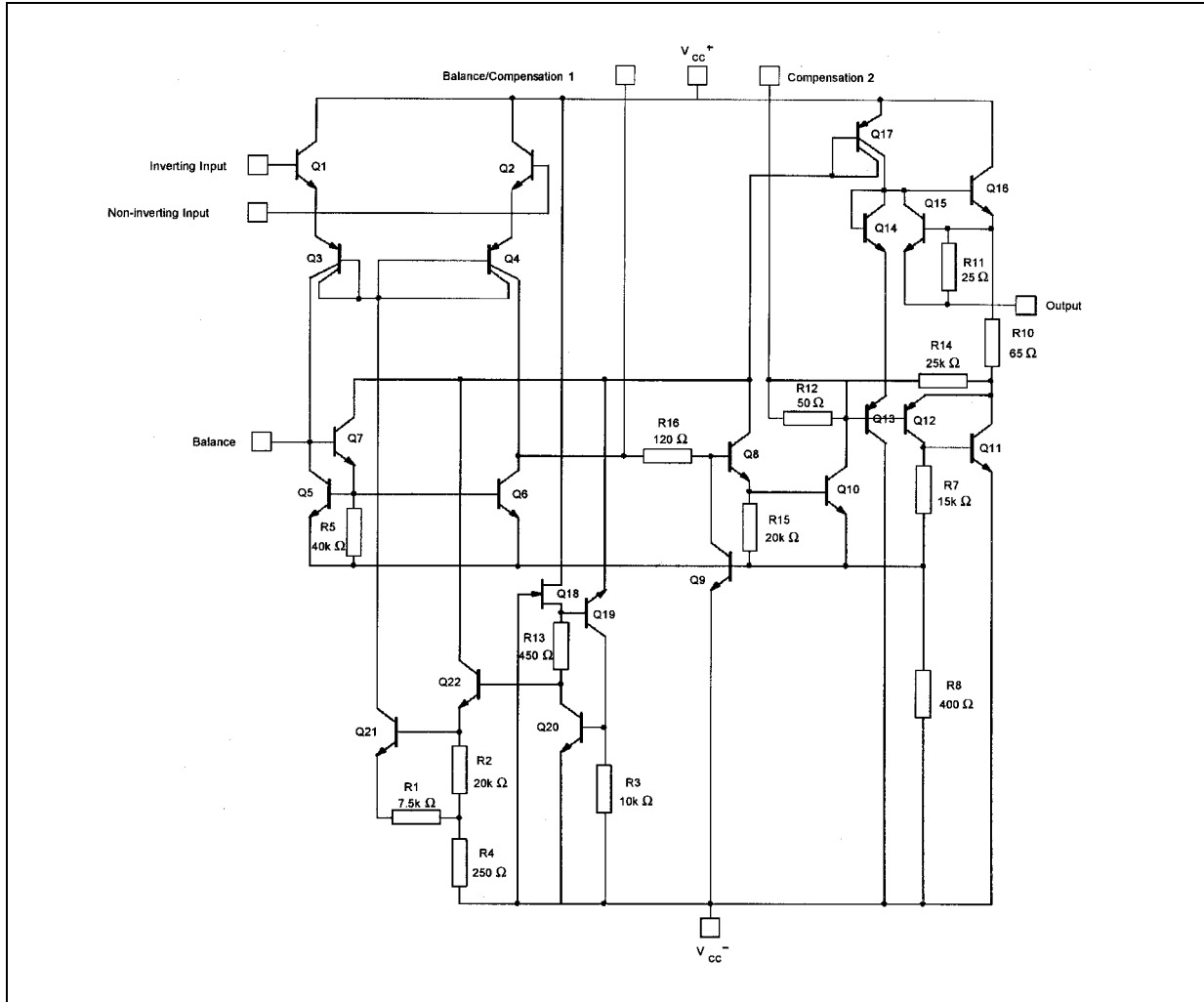

ABSOLUTE MAXIMUM RATINGS

Symbol	Parameter	LM101A	LM201A	LM301A	Unit
V_{CC}	Supply voltage	±22			V
V_i	Input Voltage	±15			V
V_{id}	Differential Input Voltage	±30			V
P_{tot}	Power Dissipation	N Suffix D Suffix			mW
	Output Short-circuit Duration	Infinite			
T_{oper}	Operating Free-air Temperature Range	-55 to +125	-40 to +105	0 to +70	°C
T_{stg}	Storage Temperature Range	-65 to +150			°C

ELECTRICAL CHARACTERISTICS $\pm 5V \leq V_{CC} \leq \pm 20V$, $C_1 = 30pF$, $T_{amb} = 25^\circ C$ (unless otherwise specified)

Symbol	Parameter	LM101A - LM201A			LM301A			Unit
		Min.	Typ.	Max.	Min.	Typ.	Max.	
V_{io}	Input Offset Voltage ($R_S \leq 10k\Omega$) $T_{amb} = +25^\circ C$ $T_{min} \leq T_{amb} \leq T_{max}$		0.7	2 3		2	7.5 10	mV
DV_{io}	Input Offset Voltage Drift $T_{min} \leq T_{amb} \leq T_{max}$		3	15		6	30	$\mu V/^\circ C$
I_{ib}	Input Bias Current - note $T_{amb} = +25^\circ C$ $T_{min} \leq T_{amb} \leq T_{max}$		25	75 100		70	250 300	nA
I_{io}	Input Offset Current $T_{amb} = +25^\circ C$ $T_{min} \leq T_{amb} \leq T_{max}$		1.5	10 20		2	50 70	nA
DI_{io}	Input Offset Current Drift $T_{min} \leq T_{amb} \leq 25^\circ C$ $T_{min} \leq T_{amb} \leq T_{max}$		10 20	100 200		10 20	300 600	$\mu A/^\circ C$
A_{vd}	Large Signal Voltage Gain * $V_O \leq 10V$, $R_L = 2k\Omega$ $T_{amb} = +25^\circ C$ $T_{min} \leq T_{amb} \leq T_{max}$	50 25	100		25 15	100		V/mV
SVR	Supply Voltage Rejection Ratio ($R_S \leq 10k\Omega$) $T_{amb} = +25^\circ C$ $T_{min} \leq T_{amb} \leq T_{max}$	80 80	96		70 70	96		dB
I_{CC}	Supply Current, no load $T_{amb} = +25^\circ C$ $T_{min} \leq T_{amb} \leq T_{max}$		1.8	3 3		1.8	3 3	mA
V_{icm}	Input Common Mode Voltage Range ($V_{CC} = \pm 20V$) $T_{amb} = +25^\circ C$ $T_{min} \leq T_{amb} \leq T_{max}$	± 15 ± 15			± 15 ± 15			V
CMR	Common Mode Rejection Ratio ($R_S \leq 10k\Omega$) $T_{amb} = +25^\circ C$ $T_{min} \leq T_{amb} \leq T_{max}$	80 80	96		70 70	96		dB
I_{OS}	Output Short-circuit Current * $T_{amb} = +25^\circ C$	10	30	50	10	30	50	mA
$\pm V_{OPP}$	Output Voltage Swing * $T_{amb} = +25^\circ C$ $T_{min} \leq T_{amb} \leq T_{max}$		$R_L = 10k\Omega$ 12 $R_L = 2k\Omega$ 10 13 $R_L = 10k\Omega$ 12 $R_L = 2k\Omega$ 10		$R_L = 10k\Omega$ 12 $R_L = 2k\Omega$ 10	$R_L = 10k\Omega$ 14 $R_L = 2k\Omega$ 13 10		V
SR	Slew Rate ($V_i = \pm 10V$, $R_L = 2k\Omega$, $C_L = 100pF$, unity gain) - ¹⁾	0.25	0.5		0.25	0.5		V/ μs

Symbol	Parameter	LM101A - LM201A			LM301A			Unit
		Min.	Typ.	Max.	Min.	Typ.	Max.	
t_r	Rise ($V_i = \pm 20\text{mV}$, $R_L = 2\text{k}\Omega$, $C_L = 100\text{pF}$, unity gain)		0.3			0.3		μs
K_{OV}	Overshoot ($V_i = 20\text{mV}$, $R_L = 2\text{k}\Omega$, $C_L = 100\text{pF}$, unity gain)		5			5		%
Z_i	Input Impedance *	1.5	4		1.5	4		$\text{M}\Omega$
GBP	Gain Bandwidth Product * ($V_i = 10\text{mV}$, $R_L = 2\text{k}\Omega$, $C_L = 100\text{pF}$, $f = 100\text{KHz}$)	0.5	1		0.5	1		MHz
THD	Total Harmonic Distortion ($f = 1\text{kHz}$, $A_v = 20\text{dB}$, $R_L = 2\text{k}\Omega$, $V_o = 2V_{pp}$, $C_L = 100\text{pF}$)		0.015			0.015		%
e_n	Equivalent Input Noise Voltage $f = 1\text{kHz}$, $R_s = 100\Omega$		25			25		$\frac{\text{nV}}{\sqrt{\text{Hz}}}$

1. May be improved up to $10\text{V}/\mu\text{s}$ in inverting amplifier configuration

* ==> $V_{CC} = \pm 15\text{V}$, $T_{amb} = +25^\circ\text{C}$ (unless otherwise specified)

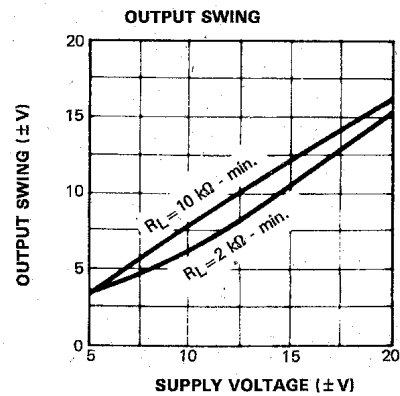
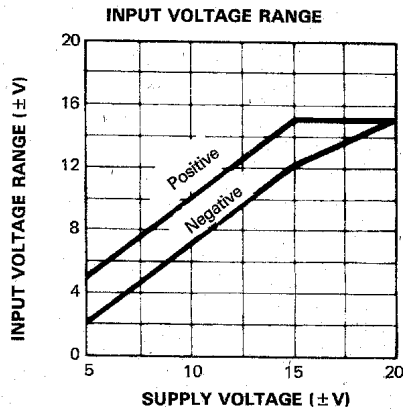

PACKAGE MECHANICAL DATA
8 PINS - PLASTIC DIP

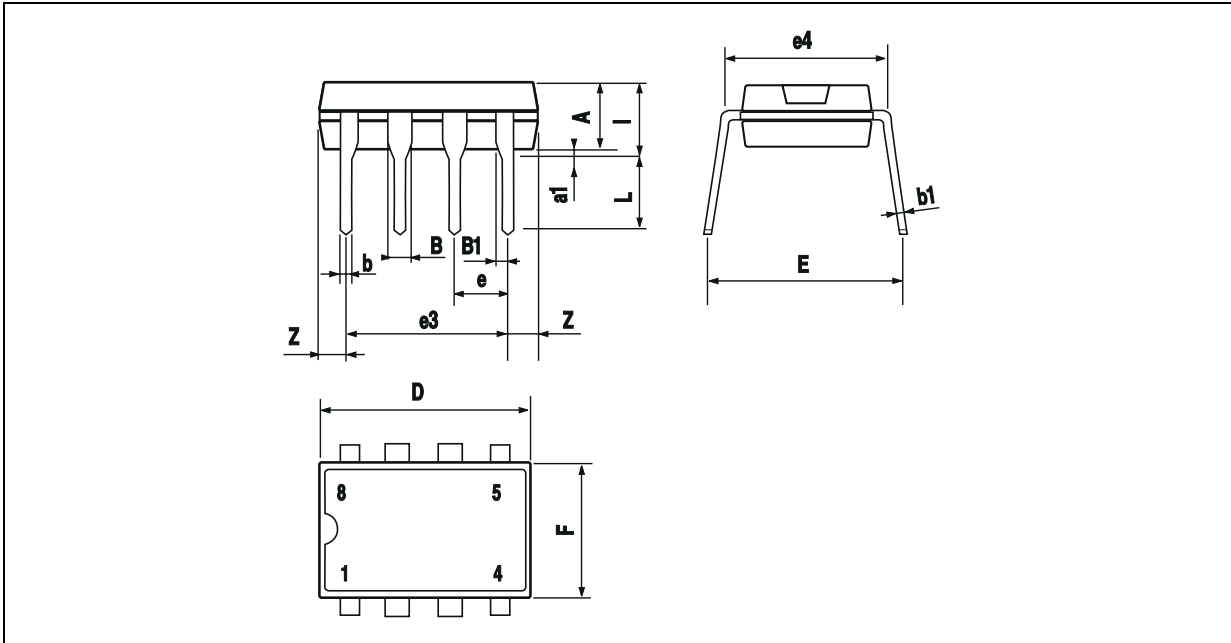

Dim.	Millimeters			Inches		
	Min.	Typ.	Max.	Min.	Typ.	Max.
A		3.32			0.131	
a1	0.51			0.020		
B	1.15		1.65	0.045		0.065
b	0.356		0.55	0.014		0.022
b1	0.204		0.304	0.008		0.012
D			10.92			0.430
E	7.95		9.75	0.313		0.384
e		2.54			0.100	
e3		7.62			0.300	
e4		7.62			0.300	
F			6.6			0.260
i			5.08			0.200
L	3.18		3.81	0.125		0.150
Z			1.52			0.060