

MC34071,2,4,A MC33071,2,4,A, NCV33074A

Single Supply 3.0 V to 44 V Operational Amplifiers

Quality bipolar fabrication with innovative design concepts are employed for the MC33071/72/74, MC34071/72/74 series of monolithic operational amplifiers. This series of operational amplifiers offer 4.5 MHz of gain bandwidth product, 13 V/ μ s slew rate and fast settling time without the use of JFET device technology. Although this series can be operated from split supplies, it is particularly suited for single supply operation, since the common mode input voltage range includes ground potential (V_{EE}). With a Darlington input stage, this series exhibits high input resistance, low input offset voltage and high gain. The all NPN output stage, characterized by no deadband crossover distortion and large output voltage swing, provides high capacitance drive capability, excellent phase and gain margins, low open loop high frequency output impedance and symmetrical source/sink AC frequency response.

The MC33071/72/74, MC34071/72/74 series of devices are available in standard or prime performance (A Suffix) grades and are specified over the commercial, industrial/vehicular or military temperature ranges. The complete series of single, dual and quad operational amplifiers are available in plastic DIP, SOIC and TSSOP surface mount packages.

Features

- Wide Bandwidth: 4.5 MHz
- High Slew Rate: 13 V/ μ s
- Fast Settling Time: 1.1 μ s to 0.1%
- Wide Single Supply Operation: 3.0 V to 44 V
- Wide Input Common Mode Voltage Range: Includes Ground (V_{EE})
- Low Input Offset Voltage: 3.0 mV Maximum (A Suffix)
- Large Output Voltage Swing: -14.7 V to +14 V (with ± 15 V Supplies)
- Large Capacitance Drive Capability: 0 pF to 10,000 pF
- Low Total Harmonic Distortion: 0.02%
- Excellent Phase Margin: 60°
- Excellent Gain Margin: 12 dB
- Output Short Circuit Protection
- ESD Diodes/Clamps Provide Input Protection for Dual and Quad
- Pb-Free Packages are Available



ON Semiconductor®

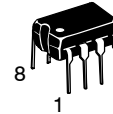

PDIP-8
P SUFFIX
CASE 626



SOIC-8
D SUFFIX
CASE 751

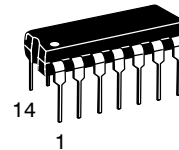

PDIP-14
P SUFFIX
CASE 646

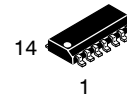

SOIC-14
D SUFFIX
CASE 751A

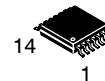

TSSOP-14
DTB SUFFIX
CASE 948G

ORDERING INFORMATION

See detailed ordering and shipping information in the package dimensions section on page 17 of this data sheet.

DEVICE MARKING INFORMATION

See general marking information in the device marking section on page 20 of this data sheet.

MC34071,2,4,A MC33071,2,4,A, NCV33074A

PIN CONNECTIONS

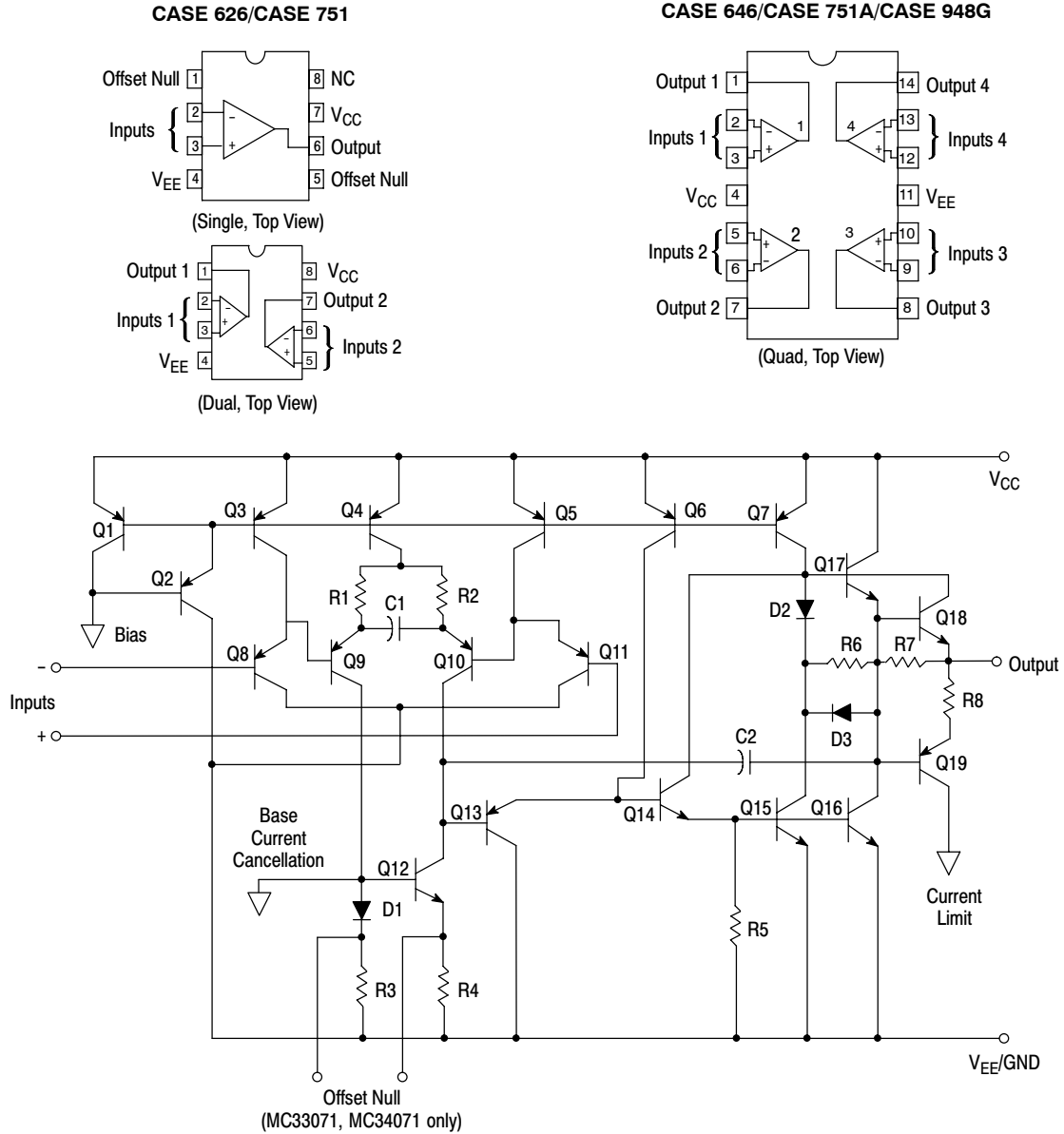

MAXIMUM RATINGS

Rating	Symbol	Value	Unit
Supply Voltage (from V_{EE} to V_{CC})	V_S	+44	V
Input Differential Voltage Range	V_{IDR}	(Note 1)	V
Input Voltage Range	V_{IR}	(Note 1)	V
Output Short Circuit Duration (Note 2)	t_{SC}	Indefinite	Sec
Operating Junction Temperature	T_J	+150	°C
Storage Temperature Range	T_{stg}	-60 to +150	°C

1. Either or both input voltages should not exceed the magnitude of V_{CC} or V_{EE} .
2. Power dissipation must be considered to ensure maximum junction temperature (T_J) is not exceeded (see Figure 2).

MC34071,2,4,A MC33071,2,4,A, NCV33074A

ELECTRICAL CHARACTERISTICS ($V_{CC} = +15\text{ V}$, $V_{EE} = -15\text{ V}$, R_L = connected to ground, unless otherwise noted. See Note 3 for $T_A = T_{low}$ to T_{high})

Characteristics	Symbol	A Suffix			Non-Suffix			Unit
		Min	Typ	Max	Min	Typ	Max	
Input Offset Voltage ($R_S = 100\ \Omega$, $V_{CM} = 0\text{ V}$, $V_O = 0\text{ V}$) $V_{CC} = +15\text{ V}$, $V_{EE} = -15\text{ V}$, $T_A = +25^\circ\text{C}$ $V_{CC} = +5.0\text{ V}$, $V_{EE} = 0\text{ V}$, $T_A = +25^\circ\text{C}$ $V_{CC} = +15\text{ V}$, $V_{EE} = -15\text{ V}$, $T_A = T_{low}$ to T_{high}	V_{IO}	-	0.5	3.0	-	1.0	5.0	mV
Average Temperature Coefficient of Input Offset Voltage $R_S = 10\ \Omega$, $V_{CM} = 0\text{ V}$, $V_O = 0\text{ V}$, $T_A = T_{low}$ to T_{high}	$\Delta V_{IO}/\Delta T$	-	10	-	-	10	-	$\mu\text{V}/^\circ\text{C}$
Input Bias Current ($V_{CM} = 0\text{ V}$, $V_O = 0\text{ V}$) $T_A = +25^\circ\text{C}$ $T_A = T_{low}$ to T_{high}	I_{IB}	-	100	500	-	100	500	nA
Input Offset Current ($V_{CM} = 0\text{ V}$, $V_O = 0\text{ V}$) $T_A = +25^\circ\text{C}$ $T_A = T_{low}$ to T_{high}	I_{IO}	-	6.0	50	-	6.0	75	nA
Input Common Mode Voltage Range $T_A = +25^\circ\text{C}$ $T_A = T_{low}$ to T_{high}	V_{ICR}	V_{EE} to $(V_{CC} - 1.8)$ V_{EE} to $(V_{CC} - 2.2)$			V_{EE} to $(V_{CC} - 1.8)$ V_{EE} to $(V_{CC} - 2.2)$			V
Large Signal Voltage Gain ($V_O = \pm 10\text{ V}$, $R_L = 2.0\text{ k}\Omega$) $T_A = +25^\circ\text{C}$ $T_A = T_{low}$ to T_{high}	A_{VOL}	50 25	100 -	- -	25 20	100 -	- -	V/mV
Output Voltage Swing ($V_{ID} = \pm 1.0\text{ V}$) $V_{CC} = +5.0\text{ V}$, $V_{EE} = 0\text{ V}$, $R_L = 2.0\text{ k}\Omega$, $T_A = +25^\circ\text{C}$ $V_{CC} = +15\text{ V}$, $V_{EE} = -15\text{ V}$, $R_L = 10\text{ k}\Omega$, $T_A = +25^\circ\text{C}$ $V_{CC} = +15\text{ V}$, $V_{EE} = -15\text{ V}$, $R_L = 2.0\text{ k}\Omega$, $T_A = T_{low}$ to T_{high}	V_{OH}	3.7 13.6 13.4	4.0 14 -	- - -	3.7 13.6 13.4	4.0 14 -	- - -	V
$V_{CC} = +5.0\text{ V}$, $V_{EE} = 0\text{ V}$, $R_L = 2.0\text{ k}\Omega$, $T_A = +25^\circ\text{C}$ $V_{CC} = +15\text{ V}$, $V_{EE} = -15\text{ V}$, $R_L = 10\text{ k}\Omega$, $T_A = +25^\circ\text{C}$ $V_{CC} = +15\text{ V}$, $V_{EE} = -15\text{ V}$, $R_L = 2.0\text{ k}\Omega$, $T_A = T_{low}$ to T_{high}	V_{OL}	- - -	0.1 -14.7 -	0.3 -14.3 -13.5	- - -	0.1 -14.7 -	0.3 -14.3 -13.5	V
Output Short Circuit Current ($V_{ID} = 1.0\text{ V}$, $V_O = 0\text{ V}$, $T_A = 25^\circ\text{C}$) Source Sink	I_{SC}	10 20	30 30	- -	10 20	30 30	- -	mA
Common Mode Rejection $R_S \leq 10\text{ k}\Omega$, $V_{CM} = V_{ICR}$, $T_A = 25^\circ\text{C}$	CMR	80	97	-	70	97	-	dB
Power Supply Rejection ($R_S = 100\ \Omega$) $V_{CC}/V_{EE} = +16.5\text{ V}/-16.5\text{ V}$ to $+13.5\text{ V}/-13.5\text{ V}$, $T_A = 25^\circ\text{C}$	PSR	80	97	-	70	97	-	dB
Power Supply Current (Per Amplifier, No Load) $V_{CC} = +5.0\text{ V}$, $V_{EE} = 0\text{ V}$, $V_O = +2.5\text{ V}$, $T_A = +25^\circ\text{C}$ $V_{CC} = +15\text{ V}$, $V_{EE} = -15\text{ V}$, $V_O = 0\text{ V}$, $T_A = +25^\circ\text{C}$ $V_{CC} = +15\text{ V}$, $V_{EE} = -15\text{ V}$, $V_O = 0\text{ V}$, $T_A = T_{low}$ to T_{high}	I_D	-	1.6 1.9 -	2.0 2.5 2.8	-	1.6 1.9 -	2.0 2.5 2.8	mA

3. $T_{low} = -40^\circ\text{C}$ for MC33071, 2, 4, /A
 $= 0^\circ\text{C}$ for MC34071, 2, 4, /A
 $= -40^\circ\text{C}$ for MC34072, 4/V

$T_{high} = +85^\circ\text{C}$ for MC33071, 2, 4, /A
 $= +70^\circ\text{C}$ for MC34071, 2, 4, /A
 $= +125^\circ\text{C}$ for MC34072, 4/V

MC34071,2,4,A MC33071,2,4,A, NCV33074A

AC ELECTRICAL CHARACTERISTICS ($V_{CC} = +15\text{ V}$, $V_{EE} = -15\text{ V}$, $R_L =$ connected to ground. $T_A = +25^\circ\text{C}$, unless otherwise noted.)

Characteristics	Symbol	A Suffix			Non-Suffix			Unit
		Min	Typ	Max	Min	Typ	Max	
Slew Rate ($V_{in} = -10\text{ V}$ to $+10\text{ V}$, $R_L = 2.0\text{ k}\Omega$, $C_L = 500\text{ pF}$) $A_V = +1.0$ $A_V = -1.0$	SR	8.0	10	-	8.0	10	-	V/ μs
Setting Time (10 V Step, $A_V = -1.0$) To 0.1% (+1/2 LSB of 9-Bits) To 0.01% (+1/2 LSB of 12-Bits)	t_s	-	1.1	-	-	1.1	-	μs
Gain Bandwidth Product ($f = 100\text{ kHz}$)	GBW	3.5	4.5	-	3.5	4.5	-	MHz
Power Bandwidth $A_V = +1.0$, $R_L = 2.0\text{ k}\Omega$, $V_O = 20\text{ V}_{pp}$, THD = 5.0%	BW	-	160	-	-	160	-	kHz
Phase margin $R_L = 2.0\text{ k}\Omega$ $R_L = 2.0\text{ k}\Omega$, $C_L = 300\text{ pF}$	f_m	-	60	-	-	60	-	Deg
Gain Margin $R_L = 2.0\text{ k}\Omega$ $R_L = 2.0\text{ k}\Omega$, $C_L = 300\text{ pF}$	A_m	-	12	-	-	12	-	dB
Equivalent Input Noise Voltage $R_S = 100\ \Omega$, $f = 1.0\text{ kHz}$	e_n	-	32	-	-	32	-	nV/ $\sqrt{\text{Hz}}$
Equivalent Input Noise Current $f = 1.0\text{ kHz}$	i_n	-	0.22	-	-	0.22	-	pA/ $\sqrt{\text{Hz}}$
Differential Input Resistance $V_{CM} = 0\text{ V}$	R_{in}	-	150	-	-	150	-	M Ω
Differential Input Capacitance $V_{CM} = 0\text{ V}$	C_{in}	-	2.5	-	-	2.5	-	pF
Total Harmonic Distortion $A_V = +10$, $R_L = 2.0\text{ k}\Omega$, $2.0\text{ V}_{pp} \leq V_O \leq 20\text{ V}_{pp}$, $f = 10\text{ kHz}$	THD	-	0.02	-	-	0.02	-	%
Channel Separation ($f = 10\text{ kHz}$)	-	-	120	-	-	120	-	dB
Open Loop Output Impedance ($f = 1.0\text{ MHz}$)	$ Z_O $	-	30	-	-	30	-	W

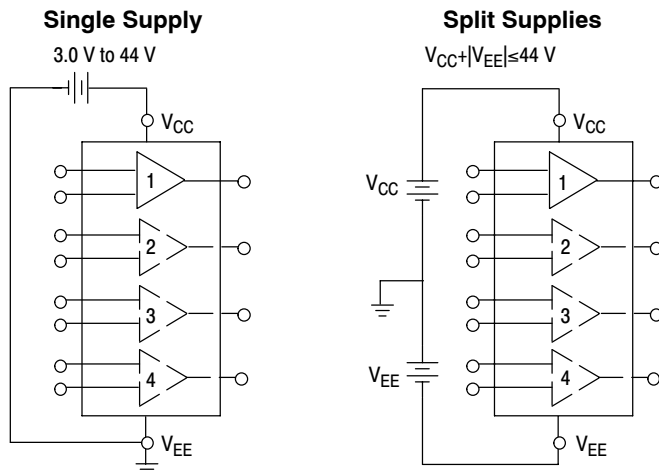
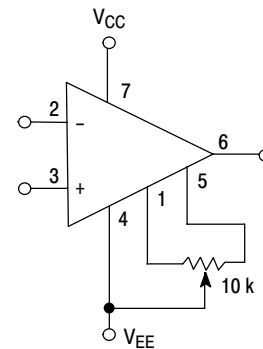

Figure 2. Power Supply Configurations



Offset nulling range is approximately $\pm 80\text{ mV}$ with a 10 k potentiometer (MC33071, MC34071 only).

Figure 3. Offset Null Circuit

MC34071,2,4,A MC33071,2,4,A, NCV33074A

ORDERING INFORMATION (continued)

Op Amp Function	Device	Operating Temperature Range	Package	Shipping [†]
Dual	MC33072P	T _A = -40° to +85°C	PDIP-8	50 Units / Rail
	MC33072PG		PDIP-8 (Pb-Free)	
	MC33072AP		PDIP-8	
	MC33072APG		PDIP-8 (Pb-Free)	
	MC33072D		SOIC-8	98 Units / Rail
	MC33072DG		SOIC-8 (Pb-Free)	
	MC33072AD		SOIC-8	
	MC33072ADG		SOIC-8 (Pb-Free)	
	MC33072DR2		SOIC-8	2500 / Tape & Reel
	MC33072DR2G		SOIC-8 (Pb-Free)	
	MC33072ADR2		SOIC-8	
	MC33072ADR2G		SOIC-8 (Pb-Free)	
	MC34072VD	T _A = -40° to +125°C	SOIC-8	98 Units / Rail
	MC34072VDG		SOIC-8 (Pb-Free)	
	MC34072VDR2		SOIC-8	2500 / Tape & Reel
	MC34072VDR2G		SOIC-8 (Pb-Free)	
MC34072VP	PDIP-8		50 Units / Rail	
MC34072VPG	PDIP-8 (Pb-Free)			
Quad	MC34074P	T _A = 0° to +70°C	PDIP-14	25 Units / Rail
	MC34074PG		PDIP-14 (Pb-Free)	
	MC34074AP		PDIP-14	
	MC34074APG		PDIP-14 (Pb-Free)	
	MC34074D		SOIC-14	55 Units / Rail
	MC34074DG		SOIC-14 (Pb-Free)	
	MC34074AD		SOIC-14	
	MC34074ADG		SOIC-14 (Pb-Free)	
	MC34074ADR2		SOIC-14	2500 Units / Tape & Reel
	MC34074ADR2G		SOIC-14 (Pb-Free)	
	MC34074DR2		SOIC-14	
	MC34074DR2G		SOIC-14 (Pb-Free)	

[†]For information on tape and reel specifications, including part orientation and tape sizes, please refer to our Tape and Reel Packaging Specifications Brochure, BRD8011/D.

MC34071,2,4,A MC33071,2,4,A, NCV33074A

ORDERING INFORMATION (continued)

Op Amp Function	Device	Operating Temperature Range	Package	Shipping [†]
Quad	MC33074P	$T_A = -40^\circ \text{ to } +85^\circ \text{C}$	PDIP-14	25 Units / Rail
	MC33074PG		PDIP-14 (Pb-Free)	
	MC33074AP		PDIP-14	
	MC33074APG		PDIP-14 (Pb-Free)	
	MC33074D		SOIC-14	55 Units / Rail
	MC33074DG		SOIC-14 (Pb-Free)	
	MC33074AD		SOIC-14	
	MC33074ADG		SOIC-14 (Pb-Free)	
	MC33074DR2		SOIC-14	2500 / Tape & Reel
	MC33074DR2G		SOIC-14 (Pb-Free)	
	MC33074ADR2		SOIC-14	
	MC33074ADR2G		SOIC-14 (Pb-Free)	
	MC33074DTB		TSSOP-14*	96 Units / Rail
	MC33074DTBG		TSSOP-14*	
	MC33074DTBR2		TSSOP-14*	2500 / Tape & Reel
	MC33074DTBR2G		TSSOP-14*	
	MC33074ADTB		TSSOP-14*	96 Units / Rail
	MC33074ADTBG		TSSOP-14*	
	MC33074ADTBR2		TSSOP-14*	2500 / Tape & Reel
	MC33074ADTBR2G		TSSOP-14*	
MC34074VD	SOIC-14	55 Units / Rail		
MC34074VDG	SOIC-14 (Pb-Free)			
MC34074VDR2	SOIC-14	2500 / Tape & Reel		
MC34074VDR2G	SOIC-14 (Pb-Free)			
MC34074VP	PDIP-14	25 Units / Rail		
MC34074VPG	PDIP-14 (Pb-Free)			
NCV33074ADTBR2G**		TSSOP-14*	2500 / Tape & Reel	

[†]For information on tape and reel specifications, including part orientation and tape sizes, please refer to our Tape and Reel Packaging Specifications Brochure, BRD8011/D.

*This package is inherently Pb-Free.

**NCV prefix for automotive and other applications requiring site and control changes.

MC34071,2,4,A MC33071,2,4,A, NCV33074A

PACKAGE DIMENSIONS

PDIP-14
CASE 646-06
ISSUE P

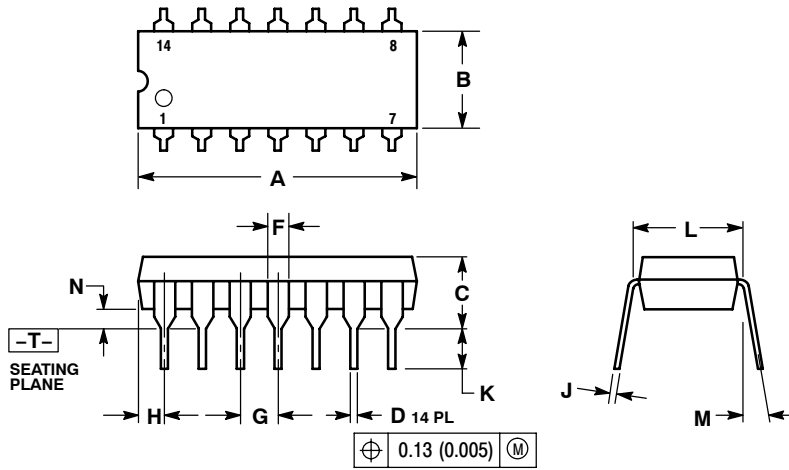

NOTES:

1. DIMENSIONING AND TOLERANCING PER ANSI Y14.5M, 1982.
2. CONTROLLING DIMENSION: INCH.
3. DIMENSION L TO CENTER OF LEADS WHEN FORMED PARALLEL.
4. DIMENSION B DOES NOT INCLUDE MOLD FLASH.
5. ROUNDED CORNERS OPTIONAL.

DIM	INCHES		MILLIMETERS	
	MIN	MAX	MIN	MAX
A	0.715	0.770	18.16	19.56
B	0.240	0.260	6.10	6.60
C	0.145	0.185	3.69	4.69
D	0.015	0.021	0.38	0.53
F	0.040	0.070	1.02	1.78
G	0.100 BSC		2.54 BSC	
H	0.052	0.095	1.32	2.41
J	0.008	0.015	0.20	0.38
K	0.115	0.135	2.92	3.43
L	0.290	0.310	7.37	7.87
M	---	10°	---	10°
N	0.015	0.039	0.38	1.01