



LM158-LM258-LM358

Low power dual operational amplifiers

Features

- Internally frequency-compensated
- Large DC voltage gain: 100 dB
- Wide bandwidth (unity gain): 1.1 MHz (temperature compensated)
- Very low supply current per operator essentially independent of supply voltage
- Low input bias current: 20 nA (temperature compensated)
- Low input offset voltage: 2 mV
- Low input offset current: 2 nA
- Input common-mode voltage range includes negative rails
- Differential input voltage range equal to the power supply voltage
- Large output voltage swing 0 V to ($V_{CC}^+ - 1.5V$)

Description

These circuits consist of two independent, high-gain, internally frequency-compensated op-amps, which are specifically designed to operate from a single power supply over a wide range of voltages. The low-power supply drain is independent of the magnitude of the power supply voltage.

Application areas include transducer amplifiers, DC gain blocks and all the conventional op-amp circuits, which can now be more easily implemented in single power supply systems. For example, these circuits can be directly supplied with the standard +5 V, which is used in logic systems and will easily provide the required interface electronics with no additional power supply.

In linear mode, the input common-mode voltage range includes ground and the output voltage can also swing to ground, even though operated from only a single power supply voltage.

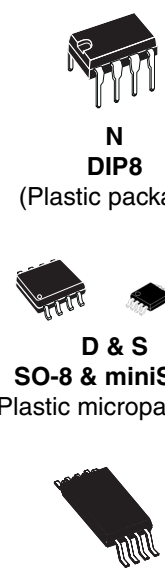

N
DIP8
(Plastic package)

D & S
SO-8 & miniSO-8
(Plastic micropackage)

P
TSSOP8
(Thin shrink small outline package)

Pin connections
(Top view)

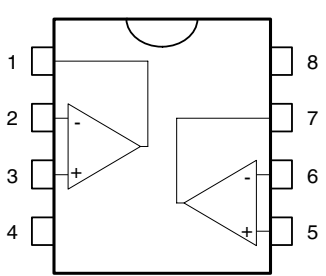

1 - Output 1
2 - Inverting input
3 - Non-inverting input
4 - V_{CC}^-
5 - Non-inverting input 2
6 - Inverting input 2
7 - Output 2
8 - V_{CC}^+

2 Absolute maximum ratings

Table 1. Absolute maximum ratings

Symbol	Parameter	LM158,A	LM258,A	LM358,A	Unit
V_{CC}	Supply voltage	+/-16 or 32			V
V_i	Input voltage	32			V
V_{id}	Differential input voltage	32			V
	Output short-circuit duration ⁽¹⁾	Infinite			
I_{in}	Input current ⁽²⁾	5 mA in DC or 50 mA in AC (duty cycle = 10%, T=1s)			mA
T_{oper}	Operating free-air temperature range	-55 to +125	-40 to +105	0 to +70	°C
T_{stg}	Storage temperature range	-65 to +150			°C
T_j	Maximum junction temperature	150			°C
R_{thja}	Thermal resistance junction to ambient ⁽³⁾				°C/W
	SO-8	125			
	MiniSO-8	190			
	TSSOP8	120			
R_{thjc}	Thermal resistance junction to case ⁽³⁾				°C/W
	SO-8	40			
	MiniSO-8	39			
	TSSOP8	37			
ESD	HBM: human body model ⁽⁴⁾	300			V
	MM: machine model ⁽⁵⁾	200			V
	CDM: charged device model ⁽⁶⁾	1.5			kV

- Short-circuits from the output to V_{CC} can cause excessive heating if $V_{CC} > 15$ V. The maximum output current is approximately 40 mA independent of the magnitude of V_{CC} . Destructive dissipation can result from simultaneous short circuits on all amplifiers.
- This input current only exists when the voltage at any of the input leads is driven negative. It is due to the collector-base junction of the input PNP transistor becoming forward-biased and thereby acting as input diode clamp. In addition to this diode action, there is NPN parasitic action on the IC chip. This transistor action can cause the output voltages of the Op-amps to go to the V_{CC} voltage level (or to ground for a large overdrive) for the time during which an input is driven negative. This is not destructive and normal output is restored for input voltages above -0.3 V.
- Short-circuits can cause excessive heating and destructive dissipation. R_{th} are typical values.
- Human body model: a 100 pF capacitor is charged to the specified voltage, then discharged through a 1.5 k Ω resistor between two pins of the device. This is done for all couples of connected pin combinations while the other pins are floating.
- Machine model: a 200 pF capacitor is charged to the specified voltage, then discharged directly between two pins of the device with no external series resistor (internal resistor < 5 Ω). This is done for all couples of connected pin combinations while the other pins are floating.
- Charged device model: all pins and the package are charged together to the specified voltage and then discharged directly to the ground through only one pin. This is done for all pins.

3 Operating conditions

Table 2. Operating conditions

Symbol	Parameter	Value	Unit
V_{CC}	Supply voltage	3 to 30	V
V_{icm}	Common mode input voltage range ⁽¹⁾	$V_{CC}^- - 0.3$ to $V_{CC}^+ - 1.5$	V
T_{oper}	Operating free air temperature range LM158 LM258 LM358	-55 to +125 -40 to +105 0 to +70	°C

1. When used in comparator, the functionality is guaranteed as long as at least one input remains within the operating common mode voltage range.

4 Electrical characteristics

Table 3. Electrical characteristics for $V_{CC}^+ = +5\text{ V}$, $V_{CC}^- = \text{Ground}$, $V_o = 1.4\text{ V}$, $T_{\text{amb}} = +25^\circ\text{C}$ (unless otherwise specified)

Symbol	Parameter	Min.	Typ.	Max.	Unit
V_{io}	Input offset voltage ⁽¹⁾ LM158A LM258A, LM358A LM158, LM258 LM358		1 2	2 3 5 7	mV
	$T_{\text{min}} \leq T_{\text{amb}} \leq T_{\text{max}}$ LM158A, LM258A, LM358A LM158, LM258 LM358			4 7 9	
DV_{io}	Input offset voltage drift LM158A, LM258A, LM358A LM158, LM258, LM358		7 7	15 30	$\mu\text{V}/^\circ\text{C}$
I_{io}	Input offset current LM158A, LM258A, LM358A LM158, LM258, LM358		2 2	10 30	nA
	$T_{\text{min}} \leq T_{\text{amb}} \leq T_{\text{max}}$ LM158A, LM258A, LM358A LM158, LM258, LM358			30 40	
DI_{io}	Input offset current drift LM158A, LM258A, LM358A LM158, LM258, LM358		10 10	200 300	$\text{pA}/^\circ\text{C}$
I_{ib}	Input bias current ⁽²⁾ LM158A, LM258A, LM358A LM158, LM258, LM358		20 20	50 150	nA
	$T_{\text{min}} \leq T_{\text{amb}} \leq T_{\text{max}}$ LM158A, LM258A, LM358A LM158, LM258, LM358			100 200	
A_{vd}	Large signal voltage gain $V_{CC}^+ = +15\text{ V}$, $R_L = 2\text{ k}\Omega$, $V_o = 1.4\text{ V}$ to 11.4 V $T_{\text{min}} \leq T_{\text{amb}} \leq T_{\text{max}}$	50 25	100		V/mV
SVR	Supply voltage rejection ratio $V_{CC}^+ = 5\text{ V}$ to 30 V , $R_s \leq 10\text{ k}\Omega$ $T_{\text{min}} \leq T_{\text{amb}} \leq T_{\text{max}}$	65 65	100		dB
I_{CC}	Supply current, all amp, no load $T_{\text{min}} \leq T_{\text{amb}} \leq T_{\text{max}}$ $V_{CC}^+ = +5\text{ V}$ $T_{\text{min}} \leq T_{\text{amb}} \leq T_{\text{max}}$ $V_{CC}^+ = +30\text{ V}$		0.7	1.2 2	mA
V_{icm}	Input common mode voltage range $V_{CC}^+ = +30\text{ V}$ ⁽³⁾ $T_{\text{min}} \leq T_{\text{amb}} \leq T_{\text{max}}$	0 0		$V_{CC}^+ - 1.5$ $V_{CC}^+ - 2$	V

Table 3. Electrical characteristics for $V_{CC}^+ = +5\text{ V}$, $V_{CC}^- = \text{Ground}$, $V_o = 1.4\text{ V}$, $T_{\text{amb}} = +25^\circ\text{C}$ (unless otherwise specified) (continued)

Symbol	Parameter	Min.	Typ.	Max.	Unit
CMR	Common mode rejection ratio $R_s \leq 10\text{ k}\Omega$ $T_{\text{min}} \leq T_{\text{amb}} \leq T_{\text{max}}$	70 60	85		dB
I_{source}	Output current source $V_{CC}^+ = +15\text{ V}$, $V_o = +2\text{ V}$, $V_{\text{id}} = +1\text{ V}$	20	40	60	mA
I_{sink}	Output sink current $V_{CC}^+ = +15\text{ V}$, $V_o = +2\text{ V}$, $V_{\text{id}} = -1\text{ V}$ $V_{CC}^+ = +15\text{ V}$, $V_o = +0.2\text{ V}$, $V_{\text{id}} = -1\text{ V}$	10 12	20 50		mA μA
V_{OH}	High level output voltage $R_L = 2\text{ k}\Omega$, $V_{CC}^+ = 30\text{ V}$ $T_{\text{min}} \leq T_{\text{amb}} \leq T_{\text{max}}$ $R_L = 10\text{ k}\Omega$, $V_{CC}^+ = 30\text{ V}$ $T_{\text{min}} \leq T_{\text{amb}} \leq T_{\text{max}}$	26 26 27 27	27 28		V
V_{OL}	Low level output voltage $R_L = 10\text{ k}\Omega$ $T_{\text{min}} \leq T_{\text{amb}} \leq T_{\text{max}}$		5	20 20	mV
SR	Slew rate $V_{CC}^+ = 15\text{ V}$, $V_i = 0.5\text{ to }3\text{ V}$, $R_L = 2\text{ k}\Omega$, $C_L = 100\text{ pF}$, unity gain	0.3	0.6		V/ μs
GBP	Gain bandwidth product $V_{CC}^+ = 30\text{ V}$, $f = 100\text{ kHz}$, $V_{\text{in}} = 10\text{ mV}$, $R_L = 2\text{ k}\Omega$, $C_L = 100\text{ pF}$	0.7	1.1		MHz
THD	Total harmonic distortion $f = 1\text{ kHz}$, $A_v = 20\text{ dB}$, $R_L = 2\text{ k}\Omega$, $V_o = 2\text{ V}_{\text{pp}}$, $C_L = 100\text{ pF}$, $V_o = 2\text{ V}_{\text{pp}}$		0.02		%
e_n	Equivalent input noise voltage $f = 1\text{ kHz}$, $R_s = 100\ \Omega$, $V_{CC}^+ = 30\text{ V}$		55		$\frac{\text{nV}}{\sqrt{\text{Hz}}}$
V_{o1}/V_{o2}	Channel separation ⁽⁴⁾ $1\text{ kHz} \leq f \leq 20\text{ kHz}$		120		dB

- $V_o = 1.4\text{ V}$, $R_s = 0\ \Omega$, $5\text{ V} < V_{CC}^+ < 30\text{ V}$, $0 < V_{\text{ic}} < V_{CC}^+ - 1.5\text{ V}$
- The direction of the input current is out of the IC. This current is essentially constant, independent of the state of the output so there is no change in the load on the input lines.
- The input common-mode voltage of either input signal voltage should not be allowed to go negative by more than 0.3 V. The upper end of the common-mode voltage range is $V_{CC}^+ - 1.5\text{ V}$, but either or both inputs can go to +32 V without damage.
- Due to the proximity of external components, ensure that stray capacitance between these external parts does not cause coupling. Typically, this can be detected because this type of capacitance increases at higher frequencies.

6.2 SO-8 package information

Figure 28. SO-8 package mechanical drawing

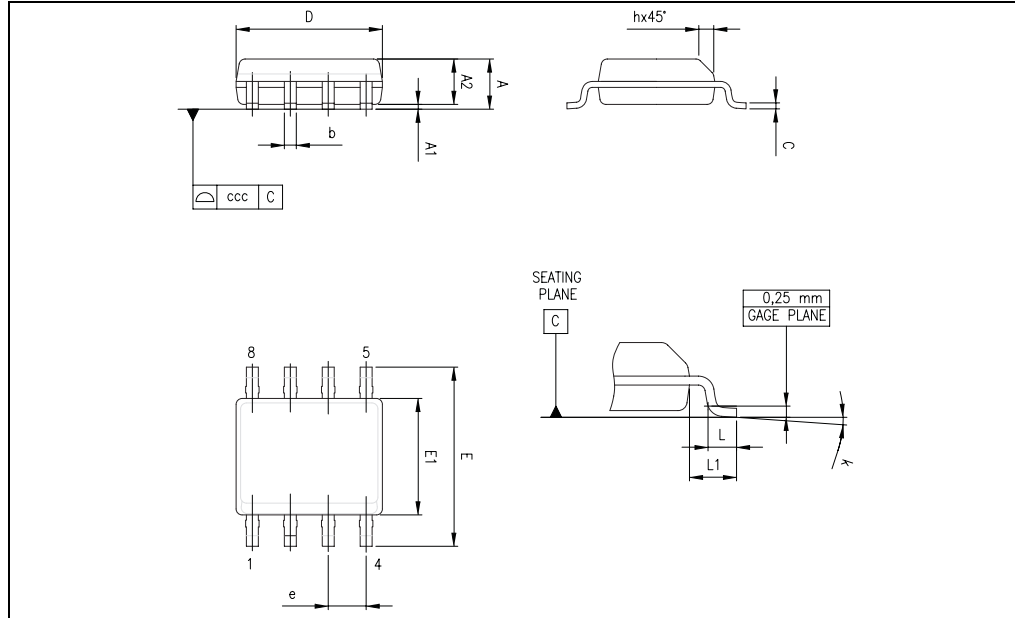

Table 5. SO-8 package mechanical data

Ref.	Dimensions					
	Millimeters			Inches		
	Min.	Typ.	Max.	Min.	Typ.	Max.
A			1.75			0.069
A1	0.10		0.25	0.004		0.010
A2	1.25			0.049		
b	0.28		0.48	0.011		0.019
c	0.17		0.23	0.007		0.010
D	4.80	4.90	5.00	0.189	0.193	0.197
E	5.80	6.00	6.20	0.228	0.236	0.244
E1	3.80	3.90	4.00	0.150	0.154	0.157
e		1.27			0.050	
h	0.25		0.50	0.010		0.020
L	0.40		1.27	0.016		0.050
L1		1.04			0.040	
k	1°		8°	1°		8°
ccc			0.10			0.004

7 Ordering information

Table 8. Order codes

Order code	Temperature range	Package	Packaging	Marking
LM158N	-55°C, +125°C	DIP8	Tube	LM158N
LM158D LM158DT		SO-8	Tube or tape & reel	158
LM158YD ⁽¹⁾ LM158YDT ⁽¹⁾		SO-8 Automotive grade		158Y
LM258AN LM258N	-40°C, +105°C	DIP8	Tube	LM258A LM258N
LM258AD LM258ADT		SO-8	Tube or tape & reel	258A
LM258AYD ⁽¹⁾ LM258AYDT ⁽¹⁾		SO-8 Automotive grade		258AY
LM258D LM258DT		SO-8	Tube or tape & reel	258
LM258YD ⁽¹⁾ LM258YDT ⁽¹⁾	SO-8 Automotive grade	258Y		
LM258PT LM258APT		TSSOP8	Tape & reel	258 258A
LM258YPT ⁽²⁾ LM258AYPT ⁽²⁾		TSSOP8 Automotive grade		258Y 258AY
LM258AST LM258ST	0°C, +70°C	MiniSO-8	Tape & reel	K408 K416
LM358N LM358AN		DIP8	Tube	LM358N LM358AN
LM358D LM358DT		SO-8	Tube or tape & reel	358
LM358YD ⁽¹⁾ LM358YDT ⁽¹⁾		SO-8 Automotive grade		358Y
LM358AD LM358ADT		SO-8		358A
LM358PT LM358APT		TSSOP8	Tape & reel	358 358A
LM358YPT ⁽²⁾ LM358AYPT ⁽²⁾		TSSOP8 Automotive grade		358Y 358AY
LM358ST LM358AST		MiniSO-8	Tape & reel	K405 K404

1. Qualified and characterized according to AEC Q100 and Q003 or equivalent, advanced screening according to AEC Q001 & Q 002 or equivalent.
2. Qualification and characterization according to AEC Q100 and Q003 or equivalent, advanced screening according to AEC Q001 & Q 002 or equivalent are on-going.